

**INTERNATIONAL CONFERENCE ON  
Science, Engineering & Technology**

28<sup>th</sup> & 29<sup>th</sup> January, 2021 | Singapore

**ICSET – 2021**



ISBN : 978-93-89107-86-9

**ORGANIZED BY**

**INSTITUTE FOR ENGINEERING RESEARCH AND PUBLICATION (IFERP)**



# **International Conference on Science, Engineering & Technology**

**ICSET-2021**

**Singapore**

**28<sup>th</sup> & 29<sup>th</sup> January, 2021**

*Organized by*

**Institute For Engineering Research and Publication  
(IFERP)**

Publisher: IFERP Explore

© Copyright 2021, IFERP-International Conference, Singapore

No part of this book can be reproduced in any form or by any means without prior written  
Permission of the publisher.

This edition can be exported from India only by publisher

IFERP-Explore

## Editorial

We cordially invite you to attend the **International Conference on Science, Engineering & Technology (ICSET-2021)** which will be held on **28<sup>th</sup> & 29<sup>th</sup> January 2021** in **Copthorne King's Hotel, Singapore**. The main objective of **ICSET-2021** is to provide a platform for Researchers, Students, Academicians as well as Industrial Professionals from all over the world to present their research results and development activities in relevant fields of Science, Engineering and Technology. This conference will provide opportunities for the delegates to exchange new ideas and experience face to face, to establish business or research relationship and to find global partners for future collaboration.

These proceedings collect the up-to-date, comprehensive and worldwide state-of-art knowledge on cutting edge development of academia as well as industries. All accepted papers were subjected to strict peer-reviewing by a panel of expert referees. The papers have been selected for these proceedings because of their quality and the relevance to the conference. We hope these proceedings will not only provide the readers a broad overview of the latest research results but also will provide the readers a valuable summary and reference in these fields.

The conference is supported by many universities, research institutes and colleges. Many professors played an important role in the successful holding of the conference, so we would like to take this opportunity to express our sincere gratitude and highest respects to them. They have worked very hard in reviewing papers and making valuable suggestions for the authors to improve their work. We also would like to express our gratitude to the external reviewers, for providing extra help in there view process, and to the authors for contributing their research result to the conference.

Since November 2020, the Organizing Committees have received more than 90 manuscript papers, and the papers cover all the aspects in Electronics, Computer Science, Information Technology, Science Engineering and Technology. Finally, after review, about 37 papers were included to the proceedings of **ICSET-2021**.

We would like to extend our appreciation to all participants in the conference for their great contribution to the success of **ICSET-2021**. We would like to thank the keynote and individual speakers and all participating authors for their hard work and time. We also sincerely appreciate the work by the technical program committee and all reviewers, whose contributions made this conference possible. We would like to extend our thanks to all the referees for their constructive comments on all papers; especially, we would like to thank to organizing committee for their hard work.



## Acknowledgement

IFERP is hosting the **International Conference on Science, Engineering & Technology (ICSET-2021)** this year in month of January. The main objective of ICSET-2021 is to grant the amazing opportunity to learn about groundbreaking developments in modern industry, talk through difficult workplace scenarios with peers who experience the same pain points, and experience enormous growth and development as a professional. There will be no shortage of continuous networking opportunities and informational sessions. The sessions serve as an excellent opportunity to soak up information from widely respected experts. Connecting with fellow professionals and sharing the success stories of your firm is an excellent way to build relations and become known as a thought leader.

I express my hearty gratitude to all my Colleagues, staffs, Professors, reviewers and members of organizing committee for their hearty and dedicated support to make this conference successful. I am also thankful to all our delegates for their pain staking effort to make this conference successful.



**Er. R. B. Satpathy**  
**CEO (Chief Executive Officer)**  
**Institute for Engineering Research and Publication (IFERP)**

## Keynote Speaker



### **Dr. Lampong Klomkul**

Director for Research,  
Information and Academic Services Division, ASEAN Studies Centre,  
Mahachulalongkornrajavidyalaya University,  
Bangkok, Thailand

### **Message**

I would like to thank to the organizing committee of IFERP inviting me as a keynote speaker with the latest emerging topic. I am believing “International Conference on Science, Engineering & Technology (ICSET-2021)” will give a lot of benefit to the participants in discussing on latest finding in engineering sciences and technology. I am particularly happy to be present in this conference and to exchange views and share experiences with participants, colleagues and friends, representing my Universities and Research group together with members of relevant international participants. I would like to welcome you to this conference and look forward to your participation.

Thanks and Regards

**Dr. Lampong Klomkul**

## Keynote Speaker



### **Rolando R. Lansigan**

Vice President,  
Internal Affairs,  
Philippine Society of Information Technology Educators - PSITE  
Philippines

### **Biography**

Doc Rolly, is an Data Privacy advocate and most-sought after Data Protection speaker and resource professional. He was the former Chief of Compliance and Monitoring Division of the National Privacy Commission from 2016-2018. After his academe and government service, he pursued his private practice as a Data Privacy Consultant, Speaker, and Educator from 2018 to present.

He also serves as a Member of Advisory Council for the Philippine National Police -Anti Cybercrime Group (PNP-ACG) and the Philippine National Police – Information Technology Management Services (PNP-ITMS).

Before he joined the government service, he served as the Dean of the College of Computer Studies and served as the man behind the program Bachelor of Science in Computer Science with Specialization in Digital Forensic, the first field of specialization in the Philippines and in the South East Asian region.

Despite his busy schedule he still serves as PACUCOA Accreditor for ITE Programs Regional Quality Assessment Team Member of CHED-NCR and Region IV for ITE and a PQA Assessor. In addition to that, he is the current Vice President for External Affairs of the Philippine Society of IT Educators, the biggest IT educators association in the Philippines.

Because of his skills and expertise in the processing of safeguarding important information from corruption and-or loss (data protection) he used to be connected in the newly created National Privacy Commission as the Chief Compliance and Monitoring Division in charge of monitoring the compliance of all organizations (private companies and government agencies) as mandated by Republic Act 10173, otherwise known as the Data Privacy Act of 2012 and also an official Ambassador of the GDPR or the General Data Protection Regulation which is based in Europe.

Thanks and Regards

A handwritten signature in blue ink, appearing to read 'R. Lansigan', written over a white background.

**Dr. Rolando R. Lansigan**  
*Consultant/Trainor*

# International Conference on Science, Engineering & Technology

## **ICSET-2021**

Singapore

28<sup>th</sup> & 29<sup>th</sup> January, 2021

**ADVISORY BOARD MEMBERS**

### **INTERNATIONAL ADVISORY COMMITTEE**

**Dr. Marmelo V. Abante**

Vice President, Mindanao, PSITE National, Dean Graduate School, World Citi College, Calabarzon, Philippines

**Dr. Luisito Lolong Lacatan**

Dean, College of Engineering, AMA UNIVERSITY - Quezon City, Philippines

**Dr. Alireza Heidari**

Full Distinguished Professor And Academic Tenure Of Chemistry, Director of the BioSpectroscopy Core Research Laboratory, Faculty of Chemistry, California South University (CSU), California, USA

**Dr Hossein Olya**

Director, Research Development For Marketing & CCI, The University of Sheffield, United Kingdom (UK), Sheffield, England

**Dr S Praveen Kumar**

Director, Bharath Institute of Higher Education and Research, Chennai, India

**Dr. Balakrishnan. S**

Principal, And Professor Of Mechanical Engineering, Sri Indu Institute of Engineering and Technology (SIET), India

**Dr. S. Gajendraraj**

Dean, Bharath Institute of Law, Bharath Institute of Higher Education & Research, India

**Dr. Sheeraz Ahmed**

Professor, Director ORIC, Iqra National University, Peshawar, Pakistan

**Dr. Dayadi. Lakshmaiah**

Professor, Electronics And Communication Engineering Academic Coordinator, and I/C R&D, Sri Indu Institute of Engineering and Technology, Hyderabad, India

**Hemlal Bhattarai**

Dean, Research And Industrial Linkages (DRIL), Royal University of Bhutan, Samdrup Jongkhar, Bhutan

**Prof. Dr. Eng. Ahmed Kadhim Hussein**

College Of Engineering, Department of Mechanical Engineering, Babylon University, IRAQ

**Yuhanis Binti Omar**

Lecturer, Information Technology, Universiti Kuala Lumpur, Malaysian Institute of Information Technology, Malaysia

**Yulia, M.Kom**

Vice Dean, Faculty of Industrial Technology, Petra Christian University, Surabaya, Indonesia

**Andreas Handojo**

Associate Professor, Faculty of Industrial Technology, Petra Christian University, Indonesia

**DR Ahmad Zuhairi Abdullah**

Professor, School Of Chemical Engineering, Universiti Sains Malaysia, George Town, Malaysia

**Dr Eileen Rose Quilon**

University of Northern Philippines, College of Business Administration and Accountancy, Philippines

**Dr Mohammad Nazri Bin Mohd Jaafar**

Professor, Universiti Teknologi Malaysia, Johor Bahru, Malaysia

**Dr Pariza Kamboj**

Professor, Computer Engineering, Sarvajanik College of Engineering and Technology, Surat, Gujarat

**Dr. Azlan Bin Adnan**

Professor, Structural Earthquake Engineering, Universiti Teknologi Malaysia (UTM), Johor Bahru, Malaysia

**Dr. Chuah Joon Huang**

Electrical Engineering, Faculty of Engineering, University of Malaya, Kuala Lumpur, Malaysia

**Dr. Efri Sandi**

Professor, Department Of Electrical Engineering, Universitas Negeri Jakarta, Jakarta, Indonesia

**Dr. Hamidi Abdul Aziz**

Professor, Environmental Engineering, School of Civil Engineering, Engineering Campus, Universiti Sains Malaysia, Malaysia

**Dr. Hla Myo Tun**

Professor & Head, Department Of Electronic Engineering, Yangon Technological University, Yangon, Myanmar (Burma)

**Dr. M. G. H. Zaidi**

Professor & Head, Department Of Chemistry, G.B.Pant University of Agriculture & Technology (GBPUAT), Pant Nagar, India

**Dr. Maamar Taleb**

Associate Professor, Electrical And Electronics Engineering, University of Bahrain, Zallaq, Bahrain

**Dr. Michelle C. Almendrala**

Assistant Professor, Research Coordinator, School of Chemical, Biological and Materials Engineering and Sciences, Mapúa University Manila, Philippines

**Dr. Muhamad Razuhanafi Bin Mat Yazid**

Department Of Civil & Structural Engineering, Faculty of Engineering & Built Environment, Universiti Kebangsaan Malaysia, Malaysia

**Dr. Nguyen Thien Bao**

RESEARCHER, FBK - Fondazione Bruno Kessler, Trento, Italy

**Dr. Osman Adiguzel**

Professor, Firat University, Elazığ, Turkey

**Dr. Ramesh T Subramaniam**

Professor, Faculty Of Science, University of Malaya, Kuala Lumpur, Malaysia

**Dr. Ren-Jye Dzeng**

Professor, Civil Engineering Department, National Chiao-Tung University, Hsinchu, Taiwan

**Dr.Sangita Babu**

Head, King Khalid University, Rejal Alma'a, King Khalid University, Abha, Saudi Arabia

**Evangeline P. Bautista**

Professor, School of Science and Engineering, Ateneo de Manila University, Philippines

**Hamidah Ibrahim**

Professor, Department Of Computer Science, Faculty of Computer Science and Information Technology, Universiti Putra Malaysia, Malaysia

**Mr Hadi Erfani**

Scientist, Chemical Engineering, Payame Noor University, Tehran,, Iran

**Muhammadou M**

Professor, IT & Computing, University of Nigeria, Gambia, western Africa

**Tanti Octavia**

Associate Professor, Head of Engineer Profession Education Department, Petra Christian University, Indonesia

**AbdulRahman Ahmed Al-Sewari**

Senior Lecturer, Faculty Of Computer Systems And Software Engineering, Universiti Malaysia Pahang, Malaysia

**Asmalina Mohamed Saat**

Senior Lecturer, Universiti Kuala Lumpur, Malaysian Institute of Marine Engineering Technology (UniKL MIMET), Kuala Lumpur, Malaysia

**Indar Sugiarto**

Associate Professor, Department Of Electrical Engineering, Petra Christian University, Surabaya, Indonesia

**Dr Duratul Ain Tholibon**

Lecturer, Faculty Of Civil Engineering, Faculty of Civil Engineering, Universiti Teknologi MARA, Shah Alam, Malaysia

**Dr Imran Ansaria**

Lecturer, Glasgow College UESTC (Systems Power & Energy), The University of Glasgow, Glasgow, Scotland

**Dr Wesam Alaloul**

Senior Lecturer, CIVIL ENGINEERING, University Technology PETRONAS, Seri Iskandar, Malaysia

**Dr. Neyara Radwan**

Professor, Mechanical Engineering, Faculty of Engineering, Suez Canal University, Egypt &Quality Assurance Officer, Ph.D. Program king Abdulaziz University, Saudi Arabia

**Dr. Agung Kristanto**

Assistant Professor, Department Of Industrial Engineering, Universitas Ahmad Dahlan, Yogyakarta, Indonesia

**Dr. Ahmed A. Elngar**

Assistant Professor, Faculty Of Computers & Artificial Intelligence, Beni-Suef University, Beni Suef, Egypt

**Dr. Felix Ling Ngee Leh**

Associate Professor, Department Of Civil Engineering, Faculty of Civil Engineering & Built Environment, University Tun Hussein Onn Malaysia, Malaysia

**Dr. Jalil Piran**

Assistant Professor, Sejong University Computer Engineering Department, Sejong University, Seoul, South Korea

**Dr. Masyitah Binti Md Nujid**

Senior Lecturer, Civil Engineering Study Centre, University of Technology MARA, Malaysia

**Dr. Mohammed Abdulrab**

Associate Professor, College of Business Administration, University of Hail, Saudi Arabia

**Dr. Nguyen Ha Duong**

Senior Lecturer, Department Of Computer Science, Faculty of Computer Science and Information Technology, Universiti Putra Malaysia, Malaysia

**Dr. Phan Van Ca**

Associate Professor, Faculty Of Electrical And Electronics Engineering, Chair of Department of Computer and Communications Engineering, HCMC University of Technology and Education, Vietnam

**Dr. Sathish Kumar Selvaperumal**

Associate Professor, Telecommunication Engineering Program Leader, Asia Pacific University of Technology and Innovation, Kuala Lumpur, Malaysia

**Dr. Subarna Shakya**

Associate Professor, Department Of Electronics And Computer Engineering, Pulchowk Campus, Institute of Engineering, Tribhuvan University, Nepal

**Dr. Shin To Amir**

Senior Lecturer, Department Of Civil Engineering, Faculty of Engineering and Built Environment, MAHSA University, Malaysia

**M Chairul Basrun Umanailo**

Assistant Professor, University of Iqra Buru, Maluku, Indonesia

**Md. Kamrujjaman**

Associate Professor, Department Of Mathematics, University of Dhaka, Bangladesh

**Dr. Rathimala Kannan**

Project Coordinator, Bachelor Of Enterprise Management Systems (Hons), Information Technology Unit /Faculty of Management, Multimedia University, Cyberjaya,, Malaysia

**Dr. Mohamed Alhadi Alrshah**

Senior Lecturer, Communication Technology And Network, Universiti Putra Malaysia, Kembangan, Malaysia.

**Dr. Praches Acharya**

Head Of Department, Department Of Computer Engineering, Lalitpur Engineering College (Affiliated to Tribhuvan University), Lalitpur, Nepal

**Dr. Tien Anh Tran**

Lecturer, Faculty Of Marine Engineering, Vietnam Maritime University, Haiphong, Vietnam

**NATIONAL ADVISORY COMMITTEE**

**Dr Wei Min Huang**

Associate Professor, School Of Mechanical And Aerospace Engineering, Nanyang Technological University Singapore

**Dr. Awad Khireldin**

Assistant Professor, Singapore Information Technology (SIT), Singapore

**Dr. Desti Kannaiah**

Senior Lecturer, School Of Business, James Cook University, Singapore

**Dr. Mukta Bansal**

Lecturer, School Of Chemical And Biomedical Engineering, Nanyang Technological University (NTU), Singapore

**Prof Hung Dinh Nguyen**

Professor, School Of Electrical & Electronic Engineering, Nanyang Technological University Singapore

**Yar Kar Peo**

Associate Professor, Singapore Institute Of Technology, Singapore

**Dr Frank Guan**

Assistant Professor, InfoComm Technology Cluster, Singapore Institute Of Technology, Singapore

**Saurabh Srivastava**

Post Doctoral Scientist, Chemistry (Nanotechnology), Singapore-MIT Alliance For Research & Technology (SMART), Singapore

**Bhavika Thakkar**

VP Sales & Alliances SEA, Aspire NXT Pte Ltd., Singapore

**Chuadhry Mujeeb Ahmed**

Research Scientist, Information Systems Technology And Design, Singapore University Of Technology And Design, Singapore

**Dr. Preeda Chaturabong**

Lecturer, Civil Engineering, Singapore Institute Of Technology Singapore



## **WELCOME MESSAGE**



### **Prof. Alex Khang**

Professor in Software Engineering,  
Director of Software Engineering, Data Scientist and AI Research,  
Co-Founder of SEFIX Organization and Former CEO of Yggdrasil Corporation,  
Vietnam

It is really my pleasure to express the delegates of International Conference on Science, Engineering & Technology (ICSET-2021) held on 28th & 29th January 2021 in the stunning city of Singapore which is organized by the Institute for Engineering Research and Publication (IFERP).

The most important thing of the Data Science research and application of the modern models in Software Engineering are serve the mutual benefits of organizations and society.

In this conference, I look forward seeing with all of you not only for getting an opportunity to exchange new ideas and experiences, but also debate about how we can share the methods of operation that will allow us to build an environment better in the future.

## **WELCOME MESSAGE**



**Dr. Hemlal Bhattarai**

Dean Research & Industrial Linkages  
Jigme Namgyel Engineering College,  
Royal University of Bhutan, Bhutan

Welcome to the International Conference on Science Engineering and Technology-Singapore (ICSET 2021). Over the year ICSET has been growing in terms of its impact and contribution in field of providing appropriate platform for the scholars. When world today is facing a stiff race of technological advancement (i.e. like AI, IoT, SMART etc), the thirst area for research and innovation has grown in length and breath. The pace of advancement in field of science and technology has gone beyond once imagination which created opportunities as well as challenges. ICSET happen to be one of the thinktank which evolved at right time and has been supporting scholars to build networks and create excellent platform to disseminate the research findings to larger mass.

As my association with ICSET progresses, I developed trust and worth contributing in whatever little way possible. Today I am honored to share this message from a tiny country (Bhutan), where many across globe know Bhutan as a country of “Gross National Happiness (GNH)”. My deepest appreciation to all the participants and organizing teams of ICSET 2021 with following message;

“Research and innovation today need to focus more on technologies that can fasten the services but, in the meantime, should not be a thread for mankind”. When world is facing tremendous pressure of climate change, our individual efforts and contribution should be such that we becoming part of the solutions seen as much crucial. I strongly recommend the scholars to think climate change, SDGs and why not explore GNH paradigm if that can help us to grow responsibly and professionally. Let this conference be an avenue for eminent professionals to think deeper about tomorrow world for mankind through innovative research and scholarly activities.

Thank you

## **WELCOME MESSAGE**



**Dr Hossein Olya**

Director of Research Development for Marketing & CCI  
The University of Sheffield,  
United Kingdom (UK)

It is a great pleasure and an honour to extend my warm invitation to all esteemed delegates to our “ International Conference on Science, Engineering & Technology (ICSET-2021)” Going to be held on 28th & 29th January, 2021 in the stunning city of Singapore. Organized by the Institute for Engineering Research and Publication (IFERP).

The ICSET- 2021 Conference will surely provide a wonderful debating platform for you to refresh your knowledge base and explore the innovations in Engineering and Technology. The Conference will strive to offer plenty of networking opportunities, providing you with the opportunity to meet and interact with the scientists and researchers.

I also look forward to your participation in oral presentations to share your technical stuff and researches. I strongly believe that this “International Conference on Science, Engineering & Technology (ICSET-2021)” will provide a fantastic opportunity for global networking and fostering research collaborations within the worldwide Engineering and Technology fraternity.

By these words I wish you a successful preparation and fruitful meeting in Singapore.

# Index

S.NO.	TITLES AND AUTHORS	PAGE NO.
1.	Study of the Readiness for Digitalization of the Industrial Enterprises in the North-Eastern Region ★ <b>Siyka Demirova</b> ★ <b>Sibel Ahmedova</b> ★ <b>Soner Aziz</b> ★ <b>Eredzep Musov</b>	1-4
2.	Digital Technology Innovations And Information Security Policy Impact On Healthcare Transformation In Developing Countries ★ <b>Ebrahim. A B.Ghaleb</b> ★ <b>P. D. D. Dominic</b> ★ <b>Rao Faizan Ali</b> ★ <b>Abid Sohail</b>	5-9
3.	Information Security Behavior of IT Professionals (Role of Polices and Compliance) ★ <b>Rao Faizan Ali</b> ★ <b>P. D. D. Dominic</b> ★ <b>Syed Emad Azhar Ali</b> ★ <b>Sheraz Naseer</b>	10-14
4.	The Development of Online Training Curriculum Base on Micro Learning and Online Social Network for Teacher in 21st Century in Test Construction Topic ★ <b>Ruangdech Sirikit</b> ★ <b>Panwasn Mahalawalert</b> ★ <b>Areeya Sriprasert</b>	15-18
5.	Macro Based Malware Detection System ★ <b>Balal Sohail</b> ★ <b>Ma'en Tayseer Ekrayem Alrashd</b> ★ <b>Yaseein Soubhi Hussein</b> ★ <b>Mohammad Tubishat</b> ★ <b>Shounak Ghosh</b> ★ <b>Ahmed Saeed Alabed</b>	19-27
6.	Exploring The Antecedents, Drivers, And Outcome Of Behaviour-Based Safety: A Literature Review ★ <b>Sujata Sinha</b> ★ <b>Dr.Ashutosh Muduli</b>	28-31
7.	Research-Based Learning Applied In First Semester Courses Of Engineering Programs (Preliminary Study) ★ <b>C. J. Diliegros-Godines</b> ★ <b>Adriana Erika Martínez-Canton</b> ★ <b>Victoria Ubici</b>	32-37

# Index

S.NO.	TITLES AND AUTHORS	PAGE NO.
8.	Solid Waste Management Strategy As An Alternative Energy Source For The Economic Driver In Gading Kasri Malang City ★ <b>Dwi Arman Prasetya</b> ★ <b>Anwar Sanusi</b> ★ <b>Grahita Chandrarin</b> ★ <b>Elfiatur Roikhah</b> ★ <b>Rahman Arifuddin</b> ★ <b>Irfan Mujahiddin</b> ★ <b>Puput Dani Prasetyo Adi</b>	38-43
9.	Factors Influence The Use Of Social Media For Environmental Sustainability Awareness In HEI ★ <b>Abeer Abdullah Abdulmajid Mohammed</b> ★ <b>Dr.PDD.Dominic</b>	44-51
10.	Power Capacity Assessment of Hybrid Diesel-Solar Photovoltaic Microgrid in Tablas Island, Romblon ★ <b>Junrey Garcia</b>	52-58
11.	The Determinants of the Innovation-Friendly Environment in Europe in the Period 2000-2019 ★ <b>Alberto Costantiello</b> ★ <b>Lucio Laureti</b> ★ <b>Angelo Leogrande</b>	59-69
12.	Challenges And Opportunities In The Field Of Information And Communications Technology (Ict) Due To Covid-19 Pandemic And Migration Towards The New Normal ★ <b>Ravenal A. De Jesus, ASEAN Eng., PECE, LPT</b>	70-75
13.	Social And Cultural Values For The Sustainability Of Local Tourism In The Province Of Cañete ★ <b>María de los Ángeles Caycho Reyna</b> ★ <b>Néstor Cuba Carbajal</b> ★ <b>Mauro Granados Maguiño</b> ★ <b>Judith Soledad Yangali Vicente</b>	76-81
14.	Solar Energy Monitoring for IOT with fault Detection and Temperature Sensing Mechanism ★ <b>Sonali Laxman Dushing</b> ★ <b>A.V.Naik</b>	82-88
15.	Virtual Reality (VR): A Review on its Application in Construction Safety ★ <b>Orlean G. DELA CRUZ</b> ★ <b>Jobelle S. DAJAC</b>	89-100

# Index

S.NO.	TITLES AND AUTHORS	PAGE NO.
16.	Single-Word Speech Recognition Using Convolutional CNN Neural Networks ★ <b>Nurbapa Mekebayev</b> ★ <b>Orken Mamyrbayev</b> ★ <b>Dina Oralbekova</b> ★ <b>Madiyar Tasbolatov</b>	101-104
17.	Gender Differences In Learning Mathematics With Digital Games ★ <b>L. K. Pulasthi Dhananjaya Gunawardhana</b>	105-110
18.	Conceptualization Of Chemical Kinetics Using A Visually Enhanced Teaching Technique; A Developed MS Excel Worksheet/System ★ <b>L.S.L.K. Fernando</b> ★ <b>K.R.R. Mahanama</b>	111-116
19.	Relevance of Zero Trust Network Architecture Amidst and It's Rapid Adoption Amidst Work From Home Enforced by COVID-19 ★ <b>Dr. Aniket Deshpande</b>	117-121
20.	Compared And Properties Of Oil Palm Empty Fruit Bunching Fibers To Be Used As A Roofing Material ★ <b>Kittisak Buasri</b> ★ <b>Prayoon Surin</b>	122-128
21.	Future of Education Post Covid-19 Pandemic: Reviewing Changes in Learning Environments and Latest Trends ★ <b>Abdullah M. Al Ansi</b> ★ <b>Ahmed Al-Ansi</b>	129-139
22.	Non-Dimensional Numbers Analysis Of A Grain Dryer ★ <b>Dhananjay Kumar</b> ★ <b>Pinakeswar Mahanta</b> ★ <b>Pankaj Kalita</b>	140-143
23.	User-Query Processing through Dynamic Tweets Status Recommender System ★ <b>V. Kakulapati</b> ★ <b>D. Vasumathi</b> ★ <b>G. Suryanarayana</b>	144-150
24.	Study the influence of Laser Energy on the Surface Morphology of Zinc Nano-particle Prepared by Pulsed Laser extirpation Method in Liquid ★ <b>Abbas M. Ali Al-Kifaie</b> ★ <b>Fares A. Yasseen</b> ★ <b>Nariman Neamah Hussein</b> ★ <b>Ali Abid Abojassim</b>	151-152

# Index

S.NO.	TITLES AND AUTHORS	PAGE NO.
25.	<p>The Moderating Role of Intellectual Capital on the Long-Run nexus of Information Security Breaches and Firms' Market Value: A Conceptual Framework</p> <p style="text-align: center;">★ <b>Syed Emad Azhar Ali</b>            ★ <b>Fong-Woon Lai</b>            ★ <b>Muhammad Kashif Shad</b>            ★ <b>Rao Faizan Ali</b>            ★ <b>Kashif Ali</b></p>	153-164
26.	<p>Nganjuk.Hitzz: Innovation Of 360o Based Tourism Information System Development Destination In Nganjuk</p> <p style="text-align: center;">★ <b>Dian Ahmad Sasmito</b>            ★ <b>LaililiaBintiMohamadSofya</b></p>	165
27.	<p>Application of the King's Philosophy in the Professional Learning Community to Develop Classroom Learning Promotion Network in Schools in Kanchanaburi Province</p> <p style="text-align: center;">★ <b>Dr. Karanphon Wiwanthamomgkon</b></p>	166
28.	<p>Business Operation Approach of Small and Medium Enterprise in Pathumthani Province</p> <p style="text-align: center;">★ <b>Dr. Pensri Bangbon</b>            ★ <b>Dr. Thanakorn Thanathanchuchot</b>            ★ <b>Dr.Yannakorn Toprayoon</b>            ★ <b>Dr. Chantip Chumdermpadejsuk</b></p>	167
29.	<p>Corrosion Studies Of Carbon Steel Using Inhibitor Of Citrus X Sinensis And Punica Granatum Peel Extract In Phosphoric Acid Medium</p> <p style="text-align: center;">★ <b>Dr. C. Stella Packiam</b>            ★ <b>D. Rathika</b></p>	168
30.	<p>Marketing Factors that Affecting the Purchase of Condominium in Bangkok Thailand</p> <p style="text-align: center;">★ <b>Dr. Pensri Bangbon</b>            ★ <b>Dr. Thanakorn Thanathanchuchot</b>            ★ <b>Dr.Yannakorn Toprayoon</b>            ★ <b>Dr. PhraSuriya Kongkawai</b></p>	169
31.	<p>Integration Of ICT In Academic And Administrative Management Processes</p> <p style="text-align: center;">★ <b>Edwin Martinez-Alvarez</b>            ★ <b>Judith Soledad Yangali Vicente</b></p>	170
32.	<p>Green Synthesis Of Metal Oxide Nanoparticles From The Whole Plant Extract Of Catharanthus Pusillus(Murr.) G.Don(Apocynaceae) And Their Enhanced Antioxidant Activity</p> <p style="text-align: center;">★ <b>Yokeswari Nithya P</b></p>	171

## Index

S.NO.	TITLES AND AUTHORS	PAGE NO.
33.	Raising Student Engagement in e-Learning Environment: An Analysis of VLE Learning Resources ★ <b>Abu Hassan Darusman</b> ★ <b>Yuhanis Omar</b>	172
34.	Studies On Mechanical, Thermal And Third Order Nlo Properties Of Potassium Magnesium Sulphate Crystals ★ <b>N.Rathna</b>	173
35.	Industrial Automation Communications and Development using High Speed Internet (IIoT With 5G) ★ <b>Yahya Alward</b> ★ <b>M. A. Ansar</b>	174
36.	Pedagogical Leadership And Educational Management In The Teaching Practice Of SENA In Colombia ★ <b>Verónica Johana Suárez Molina</b> ★ <b>José Luis Rodríguez López</b> ★ <b>Judith Soledad Yangali Vicente</b>	175
37.	The Administration Model Complexity of School under the Secondary Educational Service Area Office ★ <b>Phramaha Santichai Abhisanti</b> ★ <b>Dr. Somsak Boonpoo</b> ★ <b>Dr. Rawing Ruangsanka</b> ★ <b>Mr.Veerapan Pongvatnanusorn</b>	176





**International Conference on Science,  
Engineering & Technology**

**ICSET-2021**

**Singapore**

**28<sup>th</sup> & 29<sup>th</sup> January, 2021**

**ABSTRACTS**

Organized by

**Institute For Engineering Research and Publication (IFERP)**



# Study of the Readiness for Digitalization of the Industrial Enterprises in the North-Eastern Region

<sup>[1]</sup> Siyka Demirova, <sup>[2]</sup> Sibel Ahmedova, <sup>[3]</sup> Soner Aziz, <sup>[4]</sup> Eredzep Musov

<sup>[1][2][3][4]</sup> Technical University of Varna, Bulgaria

Email: <sup>[1]</sup>s\_demirova@tu-varna.bg, <sup>[2]</sup>sibel\_ahmet@tu-varna.bg, <sup>[3]</sup>sonerasdfghjkl@gmail.com, <sup>[4]</sup>eredzepamusov@gmail.com

**Abstract**—Digital transformation is a strategic process in which (responding to growing business challenges) business organizations use digital tools in their business activities. In this regard, it is crucial to determine the extent to which business organizations "industrial enterprises" are ready to digitize their processes. Therefore, the purpose of this publication is to examine the readiness for digitalization of industrial enterprises in the Northeast Region (NER) of Bulgaria.

**Index Terms**—digitalization, industrial enterprises, internal processes, labour market

## I. INTRODUCTION

The development of new generations of digital technologies is identified as a leading factor and basis for building a competitive national economy in the coming decades. Globally and in Europe, the effect of the application of digital technologies, and in particular in the manufacturing sector, has been identified as a strategic priority. This is one of the main goals of Industry 4.0. Industry 4.0 is a set of connected digital technology solutions that support the development of automation, integration and real-time data exchange in production processes. In essence, this reflects an industrial and technological transformation process that naturally follows the development of scientific and industrial practices. The fourth industrial transformation is a natural continuation of digitalization and automation of production and includes Internet connectivity and interaction of cyber-physical systems without human intervention, processing and analysis of large information arrays and decision-making by artificial intelligence, robotics, use of digital clouds, digital modelling and simulation of production processes through virtual reality, intelligent automation, mass production of individualized products, emergence of new technologies, creation of new business models [16,18]. Industry 4.0 is defined as part of the application of new digital technologies in the manufacturing sector and includes a wide range of technological solutions and business models that contribute to qualitatively new forms of economic activity. The Digital Economy and Society Index (DESI), reflects the achievements of the 28 EU Member States in a wide range of areas: connectivity and digital skills to the digitalization of enterprises and public services [1,6]. Data for 2019 show that the EU is making progress, but the differences between the best in digital technology and those with lower results are still significant. More effort and investment is needed to get the most out of the digital single market. Bulgaria falls into the group of lagging countries that show results below the EU average and progress more slowly than the EU as a whole [4,5,17].

## II. STUDY OF THE READINESS FOR DIGITALIZATION OF THE INDUSTRIAL ENTERPRISES IN THE NORTH-EASTERN REGION (NER)

The present study covers 65 industrial enterprises in the territory of the North-Eastern Region, classified according to the attribute "number of employees" as small, medium and large enterprises. The main sectors in which the organizations operate are: chemical and processing industry, services, machine building industry, transport and logistics. For this purpose, an online survey was conducted and the method of the interactive interview was applied. The study was conducted with the help of students from the specialty "Industrial Management" and "Technological Entrepreneurship and Innovation", members of the Student Club of "Entrepreneurship and Innovation" at the Technical University of Varna. According to the survey, 51% of the surveyed industrial enterprises are not familiar with the concept of "digital transformation of Bulgarian industry". 43% of them state that they have heard about it on various occasions, and 6% have not indicated an answer (Fig.1).

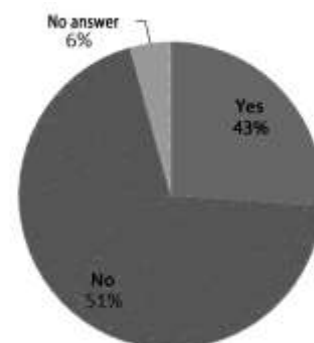

**Fig.1. Relative share of enterprises familiar with the concept of "digital transformation of the Bulgarian industry"**

To the question “Do you think that the Bulgarian industry is ready to face the challenge of “digitalization?”” 51% of the surveyed industrial enterprises indicate that the Bulgarian industry is not ready for such a challenge. 48% of companies believe that business organizations are ready, as parts of their internal processes are already digitalized. The companies that indicate that they have already digitized parts of their processes are mainly from the sectors of information and communication technologies, and business consulting services (Fig.2).

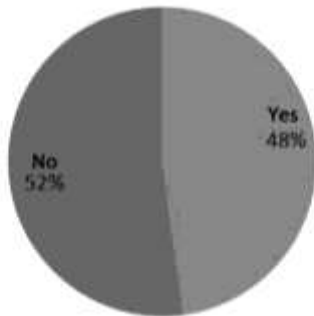

**Fig.2. Do you think that the Bulgarian industry is ready to face the challenge of "digitalization"?**

Fig. 3 shows the sectors in which business processes must be digitized. The results of the study show that the main sectors in which the level of digital business processes should be increased are: the chemical industry, the machine-building industry, the food industry, the energy sector, the processing industry and the transport and logistics sector.

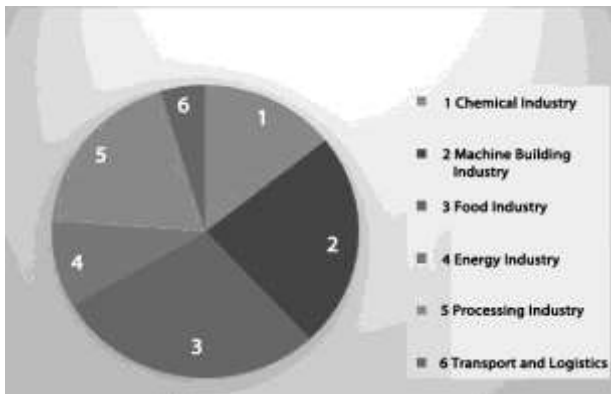

**Fig.3. In which sectors of the Bulgarian industry the business processes must be digitalized?**

It is mandatory to digitize business processes in local industries. In the first place is the food industry. It is very extensive and produces many goods and products that are consumed by the entire population. There are many business processes in the food industry that need to be digitized. According to the study, the machine-building industry ranks second in terms of digitalization, and again the arguments are the same.

The most important aspects of digitalization in mechanical engineering can be summarized in the following categories:

- Cloud-based services in mechanical engineering - the transition from automated design systems to computer-aided design systems, from on-premises software to on-demand cloud applications is a revolutionary change for engineering companies.
- Data is the new "digital glue" that connects all components and connections. Industry 4.0 and its technological capabilities are primarily informational. The shift is based on shifting the focus from physical assets to optimizing the way data treated as a valuable asset is processed, analysed and shared throughout the value chain and throughout the product life cycle. The big advantage of data is that it provides new market opportunities - huge amounts of information are created by employees, customers, processes, businesses, products and machines and can be easily generated, collected, processed and shared between companies, geographic areas and system domains.
- High-speed broadband - developing and expanding a fast and reliable Internet connection is essential for providing next-generation digital engineering support services.
- Data networks and high-performance computing centres. Generating huge amounts of data requires management, processing, storage, data security and large-scale IT resources. High-performance cloud-based computing centres will be a key resource for managing them.

The next positions are in the processing industry, the chemical industry, energy, and transport and logistics.

The survey of the readiness for digitalization of the internal company processes in the industrial enterprises in NER shows that according to 48% of the respondents they are ready to digitalize their internal company processes. Another part of the enterprises, 43% think that the business organizations are not ready for the challenges of the digital and digital transformation, and 9% of the respondents do not indicate a specific answer (Fig.4).

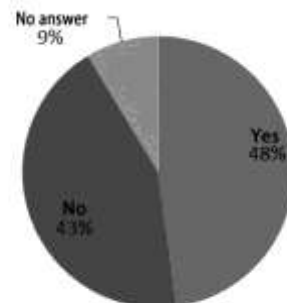

**Fig.4. Is the Bulgarian digital technology industry ready for the digitalization of internal processes?**

Industrial enterprises operate in a technological environment in which they survive only by following trends and implementing innovations and new technologies.

Business is becoming digital and many industries around the world are realizing this. Technology is evolving very fast and requires change. In order for businesses to survive in today's marketplace, they must impose these changes. Technology is the basis for creating value for consumers, creating a higher quality product or service, and they are the reason for generating revenue and profit [2,12,14].

Organizations that do not make these changes in digitalization face difficulties in their development. And these organizations, which have gradually begun to develop the process of implementing innovation, face other difficulties, but are looking for the right solutions. One change can sometimes lead to other changes and unwanted problems, and this in turn is accompanied by instability in the organizational environment.

The introduction of digital technologies in industrial enterprises will inevitably affect labour resources. On the one hand, the digitalization of processes is important, firstly, because companies must follow trends in technology, secondly, the growing demand for goods and services, changing consumer requirements, changes the market and, accordingly, companies are increasingly in need of improvement, strengthening the process of production of goods and services. This in turn will lead to the production of more products and services, which will make the company competitive. But on the other hand it will create problems in the labour market [7,10]. For example, process automation can reach 50%, and this is associated with 50% loss of labour - employees must retrain or look for another job. Thus, a significant share of jobs will not be completely replaced, but a large share of tasks will be automated, thus transforming the jobs themselves. Two thirds of jobs in the developing world are subject to automation. In nearly 50% of companies, automation will lead to certain reductions.

Fig.5 summarizes the results of the impact of digital technologies on the labour market. The survey shows that 30% of respondents believe that this will have a negative impact on the labour market, 13% - positively, and 9% said that there will be both positive and negative impact. 4% of the respondents, state that they do not know how digital technologies will affect the labour market, and 44% - did not indicate an answer.

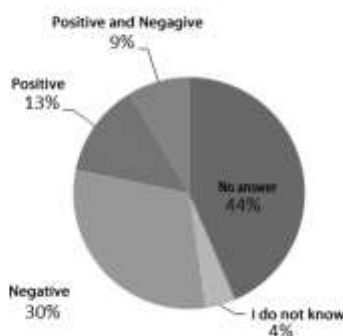

**Fig.5. Influence of digital technologies on the labour market**

It can be said that the advent of digital technologies will have a positive impact on the labour market since:

- new jobs will be created for highly qualified staff;
- young people will have more opportunities for realization;
- labour productivity will increase;
- production costs will be reduced;
- the level of poor quality production will decrease;
- finding new market niches;
- others;

The disadvantages of digital market penetration are as follows:

- increase in the unemployment rate;
- job cuts, which will be replaced by full process automation;
- requires significant investments for digitalization;
- danger of mistakes in case of poor planning;
- danger of dropping out of the market due to costs;
- others;

**III. CONCLUSION**

The digitalization of industry is a process that takes place no matter how prepared companies are for it. Those that fail to transform become uncompetitive and do not meet market requirements.

Based on the survey, the following conclusions can be drawn:

- a large percentage of the surveyed industrial enterprises indicate that the Bulgarian industry is not ready for such a challenge;
- more than half of the industrial enterprises in NER are ready to digitalize their business processes;
- almost half of the surveyed companies are ready to digitize their internal processes;
- almost half of the companies did not answer the impact of digitalization on the labour market. This may be due to the fact that the management in the enterprises still does not think about digitalization of the business processes, which is confirmed by the survey that the Bulgarian industry is not ready for such a challenge.

A huge challenge for digitalization of business processes will be the layoffs and the necessary significant investments for digitalization.

**REFERENCES**

[1] C. Cimini, R. Pinto, G. Pezzotta, P. Gaiardelli, The Transition Towards Industry 4.0: Business Opportunities and Expected Impacts for Suppliers and Manufacturers, Conference: IFIP International

- Conference on Advances in Production Management Systems, DOI: [10.1007/978-3-319-66923-6\\_14](https://doi.org/10.1007/978-3-319-66923-6_14), 2017
- [2] D.Damianov, Lifecycle of innovation and life cycle of an innovative product, International Conference on Creative Business for Smart and Sustainable Growth, 2019
- [3] D. A. Moumen, A. Darcherif, Industry 4.0: Challenges and Prospects, Génie Electrique, Productique et Management Industriel, project report, 2020
- [4] I.Dimitrov, N.Davydenko, A.Lotko and A.Dimitrova, "Comparative Study of Main Determinants of Entrepreneurship Intentions of Business Students," International Conference on Creative Business for Smart and Sustainable Growth (CREBUS), Sandanski, Bulgaria, pp. 1-4. doi:10.1109/CREBUS.2019.8840050, ISBN: 9781728134666, 2019
- [5] I.Dimitrov, A.Dimitrova, "Gender-Comparative Study the Behavioral Factors Impact on Entrepreneurship Intentions of Business Students," 2019 II International Conference on High Technology for Sustainable Development (HiTech), Sofia, Bulgaria, pp.1-4, doi: 10.1109/HiTech48507.2019.9128235., 2019
- [6] F.Stiel, F. Teuteberg, Industry 4.0 Business Models in a Sustainable Society: Challenges, Competencies and Opportunities, Conference: issenschaftstagung 2015 der Erich-Gutenberg-Arbeitsgemeinschaft Köln e.V.: Industrial Internet of Things – Managerial Challenges and Organizational Aspects, At: Nürnberg, 2015
- [7] J.Weking, M. Stöcker, M. Kowalkiewicz, M. Böhm, H. Krcmar, Archetypes for Industry 4.0 Business Model Innovations, Twenty-fourth Americas Conference on Information Systems, At: New Orleans, LA, USA, 2018
- [8] J.Carlos da Silva Freitas Junior, A. Carlos Gastaud Maçada, Examining digital capabilities and their role in the digital business performance, Revista Economia & Gestão 20(56):148, 2020
- [9] N.Dhanpat, Z. P.Buthelezi, M. Joe, T.V.Maphela, N. Shongwe, Industry 4.0: The role of human resource professionals, SA Journal of Human Resource Management 18:1-11, DOI: 10.4102/sajhrm.v18i0.1302, May 2020
- [10] N.Comerio, E. Minelli, A. Urbinati, The role of human capital in the digital transition towards Industry 4.0., Conference: XX Workshop dei Docenti e Ricercatori di Organizzazione Aziendale (WOA): Identity and Pluralism across Organizational Studies and Practices, At: Palermo, Italy, February 7-8, 2019
- [11] P.Depaoli, M. Sorrentino, M. De Marco, Social and Ethical Shifts in the Digital Age: Digital Technologies for Governing or Digital Technologies that Govern?, In book: Digital Transformation and Human Behavior, Innovation for People and Organisations DOI: [10.1007/978-3-030-47539-0\\_21](https://doi.org/10.1007/978-3-030-47539-0_21), 2020
- [12] P.Stefanova, Banks and Credit Intermediation, ed. Trakia-M, Sofia, 2000
- [13] R.Dornberger, D. Schwaferts, Digital Innovation and Digital Business Transformation in the Age of Digital Change, In book: New Trends in Business Information Systems and Technology, DOI: 10.1007/978-3-030-48332-6\_1, 2021, 2020
- [14] S.Demirova, S.Amedova, Studying entrepreneurial attitudes of students - case study of TU-Varna, International Conference on High Technology for Sustainable Development, 2019
- [15] T.Czvetko, G. Honti, J. Abonyi, Are Regions Prepared for Industry 4.0? - The Industry 4.0+ Indicator System for Assessment, Publisher: Springer International Publishing, DOI:10.1007/978-3-030-53103-42020
- [16] Digital Economy and Society Index 2017 – Bulgaria, European Commission, 2017
- [17] Best practices, measures and recommendations to promote the progress of digital and digitally-driven micro, small and medium-sized enterprises, Ministry of Economy, Republic of Bulgaria, 2019
- [18] Europe's Digital Progress Report 2016, European Commission, 2016



# Digital Technology Innovations And Information Security Policy Impact On Healthcare Transformation In Developing Countries

<sup>[1]</sup> Ebrahim. A B.Ghaleb, <sup>[2]</sup> P. D. D. Dominic, <sup>[3]</sup> Rao Faizan Ali, <sup>[4]</sup> Abid Sohail

<sup>[1][2][3]</sup> Department of Computer and Information Sciences, Universiti Teknologi PETRONAS, Seri Iskandar, Perak Darul Ridzuan, Malaysia

<sup>[4]</sup> Department of Computer Science,, COMSATS University of Science and Technology, Lahore, Pakistan  
Email: <sup>[1]</sup> ebrahim\_18003342@utp.edu.my; <sup>[3]</sup> rao\_16001107@utp.edu.my; dhanapal\_d@utp.edu.my

**Abstract**— Digital healthcare technologies in developing countries face the challenges of information security (technical and behavioral). Healthcare digital transformation plays a pivotal role in the improvement of the healthcare Performance system. New impacts of emerging technology patients in the electronic health record, risk management, security tools, big data, cloud computing, and all elements needed for better information security. This paper is a simple literature review of information security impacts and involvements in digital healthcare transformation. The literature review revealed that healthcare information security factors have a positive effect on digital healthcare transformation.

**Index Terms**— Emerging Technology, Healthcare, Digital transformation, Information security

## I. INTRODUCTION

This paper gives an efficient writing audit in the A digitalize answer for information security and digital healthcare transformation. Information technology (IT) has become the necessity of health care establishments due to the increasing need for data management and smooth working of health care systems [1]. The Increasing use of information technology in health organizations identified many errors related to the low compliance towards information security policy. Researchers of the modern world found data security breaches in health care organizations a hot area to explore [2]. Information security is as technical as a human behavioral problem.

With the passage of time and technology, information security's evolution becomes the primary concern of organizations. Health information systems (HIS) has been installed in many developing countries in the late '90s. Since then, different government and private hospitals utilizing HIS for different purposes. HIS is a multipurpose system. It holds records of patients, management of hospital staff, and administrative tasks. HIS can be used as a web application or accessed from the internet for data updates and storage. Besides ease of system accessibility, such systems can be vulnerable [3]. The data of HIS is susceptible, and it requires more security and protection. The principles of patient privacy are accepted but not accountable. Appropriate security is needed for patients' personal health information regardless of the nature of the information [4]. In healthcare environments, users do not take information security seriously. Internal employees have legitimate access to health information systems, and internal employees' negligence can harm the confidentiality of patients' personals records [5].

Health organizations are considered the most vulnerable organizations in the context of information security. Health organizations mostly focus on technical solutions for security problems than documentation and policies to diminish internal threats. Insider threats are more crucial than outsider security attacks, so health organizations must think about controlling insiders' behavioral problems. Negligence towards the organization's information security policy caused too much damage. Heavy work routine of health employees often caused security-related stress and value conflicts, which are significant reasons for non-compliance behavior. Security-related stress and value conflicts can be mitigated with organizational governance and good social bonding. This paper is a manifestation of an existing literature review on information security needs and involvements in the digital transformation of healthcare systems in developing countries.

## II. DIGITAL TECHNOLOGY IN HEALTHCARE

Digital technology in healthcare is a complex task to perform [6]. Technology is an essential component of a successful healthcare transformation [7]. The advancement of digital technology is talked about as a complex institutional change. The creators connect the stages of this transformation with the cooperation between three sorts of imaginative advances. [8]. Digital health is to be delivered at scale, there needs to be involvement from multiple stakeholders, and the government often has a central role. Understanding how governments are planning digital transformation generally, particularly healthcare, is essential for other stakeholders [9]. Information security on digitalization is a significant issue and a developing worry that influences all areas in this advanced age. The absence of data security can prompt classified data from unapproved people or the honesty of data being undermined.



Considering these, the current investigation tends to information security in developing countries [10]. According to [11], innovation technology transformation through the lens of four emerging technology fields: data analytics internet of things, blockchain cloud computing and artificial intelligence payers, all point towards the need for better information security. Digital technologies have additionally reformed our reality, and since the approach of the Internet and the World Wide Web, society has gotten more effective and progressed [12-14].

For organizations to empower employees to work in new ways, the survey findings show how and how much digitizing tools and processes can support success. We asked respondents about seven structural changes their organizations had made since the transformations began (figure 1). Three of some changes, each of which involves using digital tools, a new organizational norm emerged as keys to success.

III. INFORMATION SECURITY BEHAVIORAL IN HEALTHCARE

Healthcare industry assists with sparing and expanding patients' lives with a plan "to get individuals stable [15].

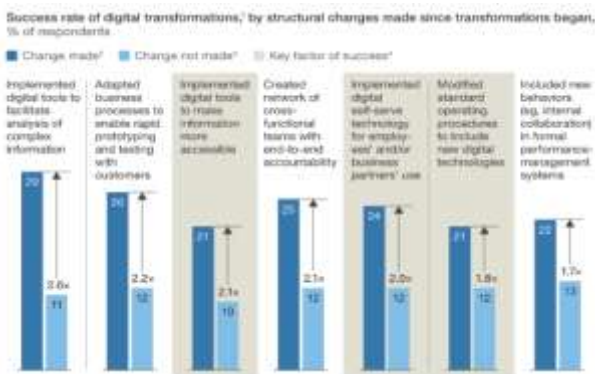

Figure 1: day-to-day tools a digital upgrade and the success rate of digital transformation.[16].

Nations utilized individual wellbeing data (PHI), which is put away and sent through digital systems [17]. The most recent years have raised the significance of existing digital frameworks like IoT applications, savvy vehicles, or modern control frameworks, and, this way, these frameworks have additionally come into the focal point of aggressors. Rather than programming items running on PCs or cell phones, refreshing and keeping up existing digital frameworks present a significant test [18]. In the information systems (IS) security writing, there has been a developing revenue in examining the issue of worker behavior that may have security suggestions in associations. It can be achieved with operational controls within a covered-entity [15, 19]. Lastly, a few information security and protection research bearings (e.g., improvement of information interoperability norms, administrative ramifications of medical services innovation selection and made sure about information exposure components) have arisen in the public arrangement space,

especially in zones, for example, clinical examination, advancement of public wellbeing data organization, fiasco reaction and evaluating of health services [13].

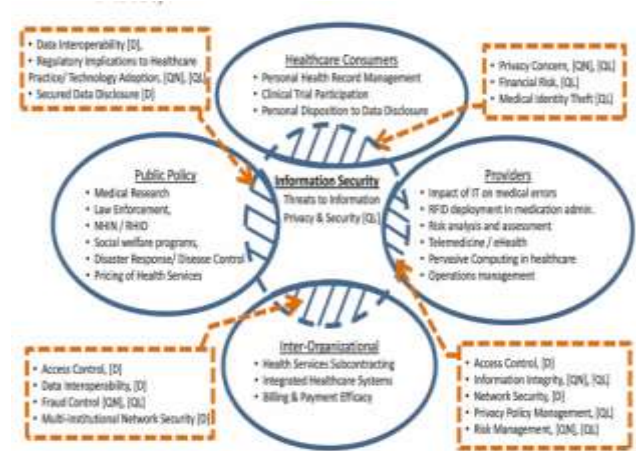

Figure 2 : Domains in the healthcare information security[13]

IV. INFORMATION SECURITY POLICY

security has gotten a lot of consideration and inclusion in the famous media and exchange diaries over recent years. Furthermore, alarmingly, the danger of assault is proceeding to develop. an information security policy compliance (ISPC) [20]. While the well-known press frequently ascribes information breaks to outside programmers, most penetrates are the aftereffect of worker remissness or potentially inability to follow information security strategies and techniques. To change representative conduct, we obtain from the authoritative atmosphere writing and present the Information Security Climate Index, created, and approved utilizing two pilot tests [21]. The examination begins by leading a progression of semi-organized meetings, including end clients' gathering, notwithstanding IT staff and data security workforce [22]. Regardless, data security is a huge test in HIS as the affectability of this information similarly as the criticality of the clinical consideration organizations extends the peril of unapproved access and introduction of characterized information [22-24]

V. DIGITAL TECHNOLOGY AND INFORMATION SECURITY POLICY

This paper presents a systematic literature review on cyber risk in the healthcare sector. The risk is defined as the combined probability of an unwanted event and its level of impact. It is described as a function of the probability that a given threat source exerts a potential vulnerability and the consequent impact of this adverse event on the organization [25]. Cyber risk, also known as information technology risk, is the new management challenge of the third millennium; it affects organizations' information and technology assets [26]. The risk failing information systems" [6]. The term "cyber" is referred to cyberspace, an interactive domain composed of all digital networks used to

store, modify, and communicate information. It includes all information systems used to support businesses, infrastructures, and services [27]. Digital technology has changed and continues to change our world under digital market transformation [28].

Digital business transformation (DBT) is a strategy that is gaining attention as companies are challenged to continually improve their business processes and capabilities. DBT stimulates new modes of working and interactions with customers, directly driving the creation of new business models. According to Weill and Woerner (2018), Digital business transformation (DBT) is a strategy that is gaining attention as companies are challenged to continually improve their business processes and capabilities. DBT stimulates new modes of working and interactions with customers, directly driving the creation of new business models. According to Weill and Woerner (2018), DBT can make firms future-ready and enhance average net revenues by 16% more than traditional firms.

**VI. CYBER ATTACKS AND THEIR AFTERSHOCKS USING INNOVATION TECHNOLOGIES**

The effect of the internet on society is unquestionable. It has given a stage to prompt correspondence, trade, and collaboration among people and associations worldwide. As the internet has filled inconspicuousness, be that as it may, lamentably so too have the number and assortment of cyberattacks [29]. Cybercrime is a critical test to society, yet it tends to be incredibly destructive to the people who become casualties. This section takes part in a complete and adequate investigation of the cybercrimes that target people [30]. As innovation and portable applications increment in volume and intricacy, vicious digital assaults are advancing, and therefore society is confronting more noteworthy security chances on the internet like never previously. To secure necessary association information and information framework resources, associations have conveyed modern observing frameworks [31, 32].

**VII. METHOD AND RESEARCH APPROACH**

**• METHOD**

This study a literature review approach to collect with gather, and dissect existing exploration concerning digital technology and information security in the computerized age from developing countries' viewpoints. This methodology is reasonable to give a synopsis of writing on the recognized issue and the investigation's resultant goals. This study using a quantitative method to investigate the factors of digital technology that influence IS perspective in healthcare units in developing countries. Thus, the methodology will be called the theoretical study.

As per the arrangement according by [33, 34] to gain a better understanding of the main problem domains, the research reviewed comprehensively previous literature in the healthcare of don developing countries including Malaysia, barriers associated with emerging technology healthcare sectors using perspective models. With the

positivist perspective being gotten in this assessment, the exploratory stage would be the chief errand whereby the examiner would need to encounter reviewing and looking over existing compositions to get how much work has been done inside the space is being examined.

In our primary research, the data will be collected from the chosen test utilizing a survey procedure. The poll procedure expects to communicate a wonder of a specific movement [35]. Therefore, the survey of this innovative technology and this questionnaire collect the data from several participants to assess several factors testing the proposed hypotheses [36]. This data questionnaire is an efficient data collection factor. The researcher knows the requirements and how to measure the variables of interest [37].

A Structural Equation Modeling Approach for the impact of Emerging Technology to Enhancement the Healthcare transformation in Malaysia. This quantitative based study, the target group of respondents, was doctors, nurses, Information technology, Professional and administrative employees. This research will distribute a total of five hundred (500) questionnaires distributed to different hospitals in Penang, Selangor, KL, Johor, and Perak.

**• RESEARCH APPROACH**

A research approach refers to a structured set of logical steps to keep the research in the right direction. In conducting a study, it is essential to select a quantitative approach. However, the application of the quantitative approach should be firmly based on the research objectives since employing the quantitative method in a research design strengthens the researcher while at the same time minimizing his weakness (Creswell 2013). A quantitative study is utilized for independent testing theories by evaluating the relationship of all the variables. This method is widely used and preferred by most of the information system researchers [38].

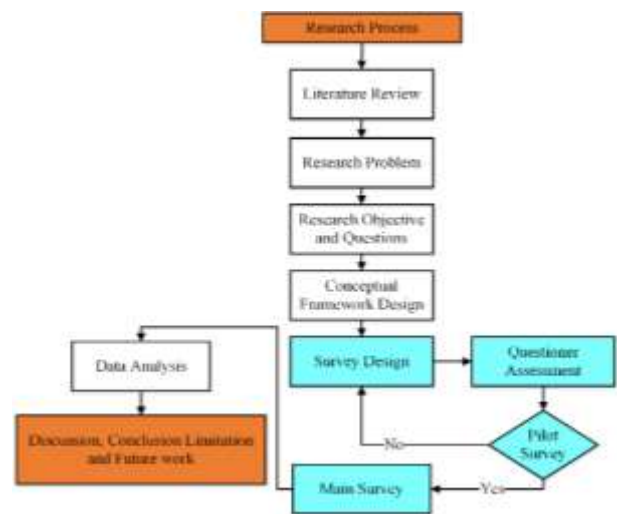

**Figure 3: Phases of the Quantitative Research Approach Adopted in the Current Study.**

Creswell, et al. [39] stated that a research process consists of several essential phases. Figure 3 illustrates the adoption of the quantitative design which can be fulfilled by following several phases: the research process, literature review, research problem, research objective and questions, conceptual framework design, survey design and data analysis and framework development.

### VIII. CONCLUSION

In conclusion, a proposal introduces the main issues and the relevant problem statements related to the research study of emerging technology and information security impact on healthcare transformation a. It discusses the specific objectives to be accomplished, the type of work to be pursued, and the research's overall scope. Furthermore, it paints an overall picture of the current research work and how it is executed. Digital technology can bridge time, distance, the affordability of healthcare and the expectation gap between consumers and clinicians. The study's future aim will be to investigate the impact of emerging technology and information security factors for healthcare transformation in Malaysia. To investigate that, 500 questionnaires will be distributed among seven hospitals in some city in Malaysia organization.

### IX. ACKNOWLEDGMENT

The authors would like to thank AP. Dr. Dhanpal Durai Dominic, and Rao Faizan Ali and Universiti Teknologi PETRONAS (UTP) and all support staff contribute to this work.

### REFERENCES

- [1] F. Alsubaei, A. Abuhussein, and S. J. I. A. Shiva, "Ontology-Based Security Recommendation for the Internet of Medical Things," *IEEE Access*, vol. 7, pp. 48948-48960, 2019.
- [2] J. W. Brady, "Securing health care: Assessing factors that affect HIPAA security compliance in academic medical centers," presented at the 2011 44th Hawaii International Conference on System Sciences, Hawaii, USA, 2011.
- [3] N. Humaidi, V. J. J. o. H. Balakrishnan, and M. Informatics, "Exploratory factor analysis of user's compliance behaviour towards health information system's security," vol. 4, no. 2, pp. 2-9, 2013.
- [4] S. R. Islam, D. Kwak, M. H. Kabir, M. Hossain, and K.-S. J. I. A. Kwak, "The internet of things for health care: a comprehensive survey," *IEEE Access*, vol. 3, pp. 678-708, 2015.
- [5] N. Humaidi and V. J. M. J. o. C. S. Balakrishnan, "The Moderating effect of working experience on health information system security policies compliance behaviour," vol. 28, no. 2, pp. 70-92, 2015.
- [6] R. Parthasarathy, J. Kern, J. R. Knight, and D. K. Wyant, "A Conceptual Model of the Role of Relative Advantage, Compatibility and Complexity in Electronic Medical Records Implementation Success," 2019.
- [7] A. Petersen, C. Tanner, and M. J. H. Munsie, "Citizens' use of digital media to connect with health care: Socio-ethical and regulatory implications," p. 1363459319847505, 2019.
- [8] N. Vasilenko, A. Linkov, and O. Tokareva, "The Interaction Between Innovative Technologies in the Course of the Institutionalization of the Digital Economy," in *III International Scientific and Practical Conference "Digital Economy and Finances"(ISPC-DEF 2020)*, 2020, pp. 44-48: Atlantis Press.
- [9] K. Benjamin and H. W. Potts, "Digital transformation in government: Lessons for digital health?," ed: SAGE Publications Sage UK: London, England, 2018.
- [10] I. J. Ikenwe, O. M. Igbinovia, and A. A. Elogie, "Information Security in the Digital Age: The Case of Developing Countries," *Chinese Librarianship*, vol. 42, pp. 16-24, 2016.
- [11] S. Akter, K. Michael, M. R. Uddin, G. McCarthy, and M. Rahman, "Transforming business using digital innovations: the application of AI, blockchain, cloud and data analytics," *Annals of Operations Research*, pp. 1-33, 2020.
- [12] P. Weill and S. L. Woerner, "Is your company ready for a digital future?," *MIT Sloan Management Review*, vol. 59, no. 2, pp. 21-25, 2018.
- [13] A. Appari and M. E. Johnson, "Information security and privacy in healthcare: current state of research," *International journal of Internet and enterprise management*, vol. 6, no. 4, pp. 279-314, 2010.
- [14] M. Graham and W. H. Dutton, *Society and the internet: How networks of information and communication are changing our lives*. Oxford University Press, 2019.
- [15] J. J. Hathaliya and S. Tanwar, "An exhaustive survey on security and privacy issues in Healthcare 4.0," *Computer Communications*, vol. 153, pp. 311-335, 2020.
- [16] H. De la Boutetière, A. Montagner, and Reich., "Unlocking Success in Digital Transformations," 2018.
- [17] N. H. Hassan and Z. Ismail, "A conceptual model for investigating factors influencing information security culture in healthcare environment," *Procedia-Social and Behavioral Sciences*, vol. 65, pp. 1007-1012, 2012.
- [18] J. Geismann and E. Bodden, "A systematic literature review of model-driven security engineering for cyber-physical systems," *Journal of Systems and Software*, vol. 169, p. 110697, 2020.
- [19] K. H. Guo, "Security-related behavior in using information systems in the workplace: A review and synthesis," *Computers & Security*, vol. 32, pp. 242-251, 2013.
- [20] S. Hina and P. D. D. Dominic, "Information security policies' compliance: a perspective for higher



- education institutions," *Journal of Computer Information Systems*, 2018.
- [21] S. R. Kessler, S. Pindek, G. Kleinman, S. A. Andel, and P. E. Spector, "Information security climate and the assessment of information security risk among healthcare employees," *Health informatics journal*, vol. 26, no. 1, pp. 461-473, 2020.
- [22] R. A. Basfar and K. Y. Bajunaied, "Information Security Assessment in King Abdullah Medical Complex: A Case Study."
- [23] S. Pirbhulal, O. W. Samuel, W. Wu, A. K. Sangaiah, and G. Li, "A joint resource-aware and medical data security framework for wearable healthcare systems," *Future Generation Computer Systems*, vol. 95, pp. 382-391, 2019.
- [24] C. Schmitz and S. Pape, "LiSRA: lightweight security risk assessment for decision support in information security," *Computers & Security*, vol. 90, p. 101656, 2020.
- [25] A. Sardi, A. Rizzi, E. Sorano, and A. Guerrieri, "Cyber Risk in Health Facilities: A Systematic Literature Review," *Sustainability*, vol. 12, no. 17, p. 7002, 2020.
- [26] K. Kandasamy, S. Srinivas, K. Achuthan, and V. P. Rangan, "IoT cyber risk: a holistic analysis of cyber risk assessment frameworks, risk vectors, and risk ranking process," *EURASIP Journal on Information Security*, vol. 2020, pp. 1-18, 2020.
- [27] C. Biener, M. Eling, and J. H. Wirfs, "Insurability of cyber risk: An empirical analysis," *The Geneva Papers on Risk and Insurance-Issues and Practice*, vol. 40, no. 1, pp. 131-158, 2015.
- [28] A. I. Urintsov, O. V. Staroverova, N. A. Mamedova, M. A. Afanasev, and M. S. Klyachin, "Consulting of Choice of Information System in the Conditions of Digital Transformation of Business," in *2019 International Conference "Quality Management, Transport and Information Security, Information Technologies"(IT&QM&IS)*, 2019, pp. 167-169: IEEE.
- [29] M. Bada and J. R. Nurse, "The social and psychological impact of cyberattacks," in *Emerging Cyber Threats and Cognitive Vulnerabilities*: Elsevier, 2020, pp. 73-92.
- [30] J. R. Nurse, "Cybercrime and you: How criminals attack and the human factors that they seek to exploit," *arXiv preprint arXiv:1811.06624*, 2018.
- [31] P. Ifinedo, "Information systems security policy compliance: An empirical study of the effects of socialisation, influence, and cognition," *Information & Management*, vol. 51, no. 1, pp. 69-79, 2014.
- [32] L. Li, W. He, L. Xu, I. Ash, M. Anwar, and X. Yuan, "Investigating the impact of cybersecurity policy awareness on employees' cybersecurity behavior," *International Journal of Information Management*, vol. 45, pp. 13-24, 2019.
- [33] S. S. Chandra, S. Chandra, and R. K. Sharma, *Sociology of education*. Atlantic Publishers & Dist, 1996.
- [34] K. A. Ratnam and P. J. I. J. o. B. I. S. Dominic, "The factors associating the adoption of cloud computing: an enhancement of the healthcare ecosystem in Malaysia," vol. 16, no. 4, pp. 462-479, 2014.
- [35] R. K. Yin, "Validity and generalization in future case study evaluations," *Evaluation*, vol. 19, no. 3, pp. 321-332, 2013.
- [36] W. G. Zikmund, J. C. Carr, and M. Griffin, *Business Research Methods (Book Only)*. Cengage Learning, 2013.
- [37] U. Sekaran and R. Bougie, *Research methods for business: A skill building approach*. John Wiley & Sons, 2016.
- [38] G. G. Gable, "Integrating case study and survey research methods: an example in information systems," *European journal of information systems*, vol. 3, no. 2, pp. 112-126, 1994.
- [39] J. W. Creswell, A. C. Klassen, V. L. Plano Clark, and K. C. Smith, "Best practices for mixed methods research in the health sciences," *Bethesda, MD: National Institutes of Health*, vol. 10, 2011.

# Information Security Behavior of IT Professionals (Role of Polices and Compliance)

<sup>[1]</sup> Rao Faizan Ali, <sup>[2]</sup> P. D. D. Dominic, <sup>[3]</sup> Syed Emad Azhar Ali, <sup>[4]</sup> Sheraz Naseer

<sup>[1][2]</sup> Department of Computer and Information Sciences, Universiti Teknologi PETRONAS, Seri Iskandar, Perak Darul Ridzuan, Malaysia

<sup>[3]</sup> Department of Management & Humanities, Universiti Teknologi PETRONAS, Seri Iskandar, Perak Darul Ridzuan, Malaysia

<sup>[4]</sup> Department of Computer Science, School of Systems and Technology, University of Management and Technology, Johar Town, Lahore, Pakistan

Email: <sup>[1]</sup> rao\_16001107@utp.edu.my; <sup>[2]</sup> dhanapal\_d@utp.edu.my; <sup>[3]</sup> syed\_17007896@utp.edu.my

**Abstract**— Information security seems to be a technical subject, but it is as behavioral as technical. Most of the security breaches occur due to the negligence of internal employees towards information security policy. Lack of compliance with information security policies is a multidimensional problem, and it requires technical and behavioral solutions. There is plenty of research available for behavioral information security, but most of the research is conducted upon non-IT (information technology) users or non-specialized users. This research paper is a pilot study for testing the information security policy compliance of IT professionals. Hypotheses were formulated from the literature review, and a framework was developed. The framework consisted of organizational management constructs and two behavioral theories (protection motivation theory and theory of planned behavior). This pilot study showed that organizational management can enhance employees' protection motivation, which later cultivates good information security behavior towards information security policy compliance.

**Index Terms**— Information Security Behavior, Information Security Policy Compliance, Protection Motivation, Organizational Management

## I. INTRODUCTION

Information security is considered as the most critical aspect of information technology. Organizations related to all businesses are investing in information security for their data and operations safety. Most organizations consider and invest in technical controls, but eighty percent of data and security breaches occur because of human negligence. According to the Verizon cybersecurity investigation report 2018, almost 53,000 security attacks were reported from which 2216 were confirmed data breaches. The report only published the reported attacks; many organizations never confirm data breaches because of fear of losing reputation in the market [1]. According to Verizon insiders, behavioral misuse is one of the prominent reasons for security breaches. In 2017 human negligence was considered the second top reason for security breaches. Insider misuse of privileges, lack of information security awareness, and deviant behavior from the information security policies are considered crucial factors behind any data breach [2].

Information security in organizations incorporates a very complicated process that involves many factors, such as education, the human element, and technology, which are necessary to be managed under one security model. Structuring this type of framework with all these processes according to information security standards and policies such as enterprise information security studies progressed rapidly worldwide [3]. Security policies are the set of written rules which define security levels in organizations, and all employees must comply with these guidelines [4].

Enterprise information security policies consist of rules and regulations; it is just like a rule book that every legitimate user of the information system should follow. Information security policies are different for every organization; most policies include aims and goals, protection of security controls, instruction of use, protection, and disruption of enterprise's information entities. An organization needs to elaborate its security requirements, and defining requirements will help to determine necessary management actions and prerequisites to manage information security controls [3].

The purpose of this research is to evaluate and examine information security policy compliance (ISPC) of IT-based employees. A research framework has been designed with the help of behavioral theories to determine compliance. It is a pilot study to evaluate the research model and instrument analysis. The next section consists of the background, research framework, and hypothesis described in section three. The research method and results are demonstrated in sections four and five, respectively.

## II. BACKGROUND AND MOTIVATIONS

The understanding between information technology and employee behavior is the critical aspect to establish adequate information security [5-7]. Information security culture is another vital factor; reasonable information security culture cultivates better ISPC. Employees' better understanding of information security and knowledge sharing among each other creates good security culture. Organizational management can enhance information

security culture, security education and training, effective ways of implementing security policy and procedure, and good security governance.

To protect information systems, the standards ISO 27000, ISO 27001, and ISO 27002 provide requirements and guidelines, specific controls, and control objectives with which the organization can accomplish enough information security [8]. The International Organization for Standardization publishes these standards in conjunction with the International Electrotechnical Commission. It is challenging for each enterprise to select the most suitable set of standards that fulfill their needs[9]. The ISO 27000, 27001, and 27002 standards form a Model to plan and control ISMS. These organizations are offered the chance to align their IT processes and methods for assuring an adequate degree of information security with an international standard [8].

In previous information security behavior studies, the research sample consists of business, management, or other field participants. Most of the research presented in behavioral information security has been performed upon non-IT professionals. Simultaneously, some of the research performed on IS (information systems) specialist's dataset. One of the research studies conducted on a different group of employees to assess role values resulting in IT employees had more complacent behavior than non-IT employees[10]. Similarly, [11] included IS specialists and management employees, but they never distinguish between the two groups. [12] also studied protection motivation on information security personals with insiders. However, except for very few studies, there is significantly less research focused on IT staff and specialized users.

### III. RESEARCH METHODOLOGY

ISPC is a multidimensional problem, and for solving such a problem, a comprehensive framework is needed. So, we proposed a research framework based on organizational management and two behavioral theories. Organizational management is responsible for the enforcement of information security policies and procedures. Management provides all the festive activities which can cultivate good security culture in an organization. For our research framework, the researcher has selected three management constructs (Security education and training programs (SETA), security policy and procedures (SPP), and workplace capabilities (WPC). Two behavior theories were selected for this research first protection motivation theory (PMT), and the second is the theory of planned behavior (TPB).

The protection motivation theory initially presented by Rogers R in 1975; the protection motivation theory was created for fear appeals [13]. PMT consisted of two appraisals threat appraisal and coping appraisal. Threat appraisal addresses how people react when they get a threatening situation, and coping appraisal describes how people cope with the occurred threat. PMT describes people protect themselves from any threatening situation in four

ways; the perceived probability of the threat occurrence, perceived severity of a threatening event, recommended preventive behavior efficacy, and perceived self-efficacy. With the help of a literature review in this paper, perceived vulnerability (PV), perceived severity (PS), response efficacy (RE), and self-efficacy (SE), has been selected from PMT.

Icek Ajzen initially presented the theory of planned behavior (TPB) to improve the theory of reasoned action in 1991 [14]. TPB is used in various behavioral information security studies. It is the most used theory for behavior prediction in the last decade. The theory of planned behavior describes how an individual develops his intention towards actual behavior. TPB also describes the norms and perceived behavioral control effect in the actual behavior of an individual. TPB argues that an individual's actual behavior is shaped by four components attitude (AT), perceived behavioral control (PBC), subjective norms, and intention.

This research paper is an effort to construct and test a theoretical framework. This suggests that organizational management can enhance protection motivation, and adequate protection motivation can improve employees' security behavior. For organizational management researcher has taken SETA programs, SETA programs proved to be very influential in enhancing user information security behaviors [15]. The second construct in organizational management is SPP. The research argues that in-line security policy and procedures can enhance protection motivation among employees[16]. Third, workplace capabilities (job security, job satisfaction, etc.) also significantly affect employees' behaviors towards ISPC [17-19]. Hence this research proposes:

#### Hypothesis 1

**H1a:** SETA Programs have positive effects on the employees' perceived vulnerability (PV)

**H1b:** SETA Programs have positive effects on the employees' perceived severity (PS)

**H1c:** SETA Programs have positive effects on the employees' response efficacy (RE)

**H1d:** SETA Programs have positive effects on the employees, self-efficacy (SE)

#### Hypothesis 2

**H2a:** (SPP) have positive effects on the employees' perceived vulnerability (PV)

**H2b:** (SPP) have positive effects on the employees' perceived severity (PS)

**H2c:** (SPP) have positive effects on the employees' response efficacy (RE)

**H2d:** (SPP) have positive effects on the employees, self-efficacy (SE)

### Hypothesis 3

**H3a:** WPC has positive effects on the employees' perceived vulnerability (PV)

**H3b:** WPC has positive effects on the employees' perceived severity (PS)

**H3c:** WPC has positive effects on the employees' response efficacy (RE)

**H3d:** WPC has positive effects on the employees, self-efficacy (SE)

### Hypothesis 4

**H4:** perceived vulnerability (PV) influences Intention towards the security policy compliance.

### Hypothesis 5

**H5:** perceived severity (PS) influences Intention towards the security policy compliance

### Hypothesis 6

**H6:** response efficacy (RE) influences Intention towards the security policy compliance

### Hypothesis 7

**H7:** self-efficacy (SE) influences Intention towards the security policy compliance

### Hypothesis 8

**H8:** Attitude (AT) influences Intention towards the security policy compliance

### Hypothesis 9

**H9:** Perceived Behavioral Control (PBC) influences Intention towards security policy compliance

This study was survey-based research, and a self-administered questionnaire is best for these types of studies [20]. The questionnaire was the primary data collection tool, and constructs for instruments were adapted from various studies. Questions for SETA, SPP, and WPC were taken from [21-23]. Questions for the perceived vulnerability (PV), perceived severity (PS), response efficacy (RE), self-efficacy (SE) [16]. Questions for attitude perceived behavioral control and intention towards security policy were adapted from [21-23]. Items were evaluated through a 1 to 5 Likert-scale from 1 strongly disagree to 5 strongly agree. The survey was conducted in an IT firm located in Perak Malaysia, with google forms.

All the participants were informed about this research, and all the questionnaires were filled by the participants own will and choice. There were no controlled environment or predetermined rules for filling the questionnaire. Total of 53 people participated in this research. After data screening, 4 out of 53 responses were not eligible to include; therefore, 49 usable responses were collected. The convenience sampling technique was used for data collection, as this is the most suitable sampling technique for pilot studies [24].

SPSS V23 was used for descriptive data analysis; four data analysis tests were performed for this paper normality, reliability, correlation, and factor analysis.

## IV. RESULTS AND DISCUSSION

The normality test determines the variance and outliers in the data. If data is not in good shape, then outliers should be removed from the data. Data normality test is determined by two fundamental values Kurtosis and Skewness. If the values of Kurtosis and Skewness are between  $\pm 2.58$ , then the data is considered normal, but data is considered abnormal if the values are above or less than this value. The data for this research was found to be normal.

Factor analysis is used to reduce the larger dimensions into smaller dimensions of factors [25]. For this research, we have used EFA and principal axis factor technique (PFA) with Promax rotation. Factor loadings of factors determine whether this factor is reliable for future use or not if a factor's value should be greater than 0.5. A detailed factor analysis was performed for this study, and factors with low values removed 43 items, and 10 elements were finalized for the primary research.

After the factor analysis reliability test is performed upon data, the reliability test determines the internal consistency between the elements, and reliability is denoted by Cronbach's Alpha [26]. The threshold values for reliability suggested by Ho et al. showed in Table I; if the Cronbach's Alpha value is less than 0.7, it is considered the weak measurement tool, and the researcher should not rely on the questionnaire [20].

**Table I: Ho et al Threshold Values**

Cronbach's Alpha	Values
Value > 0.7	Acceptable
Value > 0.8	Good
Value > 0.9	Excellent

Items with low Cronbach's Alpha values are considered bad for future research and keeping those values risk the questionnaire's reliability [27]. So, we removed low-value items for the primary research; all the items shown good reliability values except 2 items; the reliability results are shown in Table II.

**Table II: Reliability Analysis**

Construct	No of items	Cronbach's Alpha	Revised No Items	Revised Cronbach's Alpha
SETA	5	0.905	5	0.905
SPP	5	0.835	4	0.825
WPC	5	0.905	4	0.905
PV	5	0.923	4	0.923
PS	4	0.930	4	0.930
RE	4	0.812	3	0.805
SE	4	0.845	4	0.845
ATT	4	0.920	4	0.920
PBC	4	0.882	4	0.882
ISPC	5	0.915	4	0.915
<b>Overall Reliability</b>	<b>45</b>	<b>0.952</b>	<b>43</b>	<b>0.943</b>



Finally, the researcher has conducted a correlation test upon the data; Table III presented the correlation results. The correlation test determines how much one factor is correlated with another. If two values are significantly correlated, it means both the factors have some commonness in them. For this paper, the researcher

conducted a Pearson correlation test, the Pearson coefficient denoted by 'r.' The range of r is between -1 to +1; the value near +1 is considered a significant relationship, and the value near -1 is considered a negative or weak relationship [20].

**Table III: Correlation Analysis**

	SETA	SPP	WPC	PV	PS	RE	SE	ATT	PBC	ISPC
SETA	1									
SPP	.815	1								
WPC	.765**	.787**	1							
PV	.625**	<b>.748**</b>	.715**	1						
PS	<b>.742**</b>	<b>.731**</b>	<b>.843**</b>	.706**	1					
RE	.653**	.662**	<b>.769**</b>	.723**	.512**	1				
SE	<b>.877**</b>	<b>.717**</b>	<b>.712**</b>	.584**	.757**	.578**	1			
ATT	.711**	.678**	.673**	.835**	.735**	.665**	.722**	1		
PBC	.746**	.724**	.701**	.906**	.741**	.716**	.748**	.933**	1	
ISPC	.654**	.713**	.744**	<b>.910**</b>	<b>.770**</b>	<b>.598**</b>	<b>.608**</b>	<b>.789**</b>	<b>.840**</b>	1

N=49 Correlation is significant at the 0.01 level (2-tailed).  
 Note: Bold Values Demonstrate Hypothesized Associations in the Research Framework.

Based on correlation results, SETA Programs have significant effects on perceived severity and self-efficacy; SETA programs can enhance an employee's perceived severity and self-efficacy. Security policy and procedures affect positively perceived vulnerability and perceived severity about threats; moreover, SPP has shown significance towards self-efficacy. Workplace capabilities have shown a positive impact on perceived severity, response efficacy, and self-efficacy. Moreover, all the PMT constructs have demonstrated a good correlation with ISPC. The perceived vulnerability has shown a correlation of 9.10; it depicts that organizational management can enhance perceived vulnerability, and later on, it can help cultivate good ISPC attitude, and perceived behavioral control also shown a positive correlation with ISPC. Correlation results determine all the hypotheses had strong associations except H1a, H1c, H2c, H3a, H4a, and H4d. So the researcher intended to remove these hypotheses from the main study.

### V. CONCLUSION

This study was conducted for evaluating ISPC from IT professionals; we have determined that organizational management can enhance protection motivation among individuals, and enhanced protection motivation is very effective towards ISPC. The researcher conducted the study in an IT firm; all the respondents almost familiar with information security and its policies. The study results showed that organizational management can improve the IT user's protection motivation, and enhanced protection motivation can reduce employees' deviant Information security behaviors.

In the future, the researcher intended to experiment with a bigger dataset of IT professionals of Malaysia. For getting more insights into the problem researcher aim to collect

data above 250 IT professionals. Structural equation modeling will be used for results and data analysis of the main study.

**Funding:** This work was supported in part by YUTP-FRG Grant (015LCO-171).

### REFERENCES

- [1] S. Widup, M. Spitler, D. Hylender, and G. Bassett, Verizon Data Breach Investigations Report, (2018) [https://www.verizonenterprise.com/resources/reports/rp\\_DBIR\\_2018\\_Report\\_en\\_xg.pdf](https://www.verizonenterprise.com/resources/reports/rp_DBIR_2018_Report_en_xg.pdf).
- [2] R. Willison, and M. Warkentin, Beyond deterrence: An expanded view of employee computer abuse, MIS Quarterly 37 (1) (2013) pp. 1-20.
- [3] EY. Yildirim, G. Akalp, S. Aytac, and N. Bayram, Factors influencing information security management in small-and medium-sized enterprises: A case study from Turkey, International Journal of Information Management 31 (4) (2011) pp. 360-365.
- [4] C. Cresson Wood: 'Information Security Policies Made Easy' (Information Shield Publisher, 2005. 2005)
- [5] CC Wood, Policies alone do not constitute a sufficient awareness effort, Computer Fraud & Security 1997 (12, December) (1997) pp. 14-19.
- [6] R.A. Willison: 'Opportunities for computer abuse: Assessing a crime specific approach in the case of Barings Bank', London School of Economics and Political Science (United Kingdom), 2002
- [7] A. Shostack, and A. Stewart: 'The new school of information security' (Pearson Education, 2008, 1 edn. 2008)



- 
- [8] G. Disterer, ISO/IEC 27000, 27001 and 27002 for information security management, *Journal of Information Security* 4 (1) (2013) pp. 92-100.
- [9] P. Năstase, F. Năstase, and C. Ionescu, Challenges generated by the implementation of the IT standards CobiT 4.1, ITIL v3 and ISO/IEC 27002 in enterprises, *Economic Computation & Economic Cybernetics Studies & Research* 43 (1) (2009) pp. 1-16.
- [10] G.D. Moody, M. Siponen, and S. Pahlila, Toward a unified model of information security policy compliance, *MIS Quarterly* 42 (1) (2018) pp. 285-312.
- [11] P. Ifinedo, Information systems security policy compliance: An empirical study of the effects of socialisation, influence, and cognition, *Information & Management* 51 (1, January) (2014) pp. 69-79.
- [12] C. Posey, T.L. Roberts, P.B. Lowry, and R.T. Hightower, Bridging the divide: A qualitative comparison of information security thought patterns between information security professionals and ordinary organizational insiders, *Information & Management* 51 (5, July) (2014) pp. 551-567.
- [13] R.W. Rogers, A protection motivation theory of fear appeals and attitude change<sup>1</sup>, *The journal of Psychology* 91 (1) (1975) pp. 93-114.
- [14] L. Beck, and I. Ajzen, Predicting dishonest actions using the theory of planned behavior, *Journal of Research in Personality* 25 (3) (1991) pp. 285-301.
- [15] W. Yaokumah, DO. Walker, and P. Kumah, SETA and Security Behavior: Mediating Role of Employee Relations, Monitoring, and Accountability, *Journal of Global Information Management* 27 (2) (2019) pp. 102-121.
- [16] S. Hina, DDDP Selvam, and P.B. Lowry, Institutional governance and protection motivation: Theoretical insights into shaping employees' security compliance behavior in higher education institutions in the developing world, *Computers & Security* 87 (November) (2019) pp. 101594.
- [17] A. Da Veiga, and N. Martins, Defining and identifying dominant information security cultures and subcultures, *Computers & Security* 70 (September) (2017) pp. 72-94.
- [18] S. Furnell, and A. Rajendran, Understanding the influences on information security behaviour, *Computer Fraud & Security* 2012 (3, March) (2012) pp. 12-15.
- [19] K. Höne, and J.H.P. Eloff, Information security policy—what do international information security standards say?, *Computers & Security* 21 (5, October) (2002) pp. 402-409.
- [20] HO. Madsen, S. Krenk, and NC. Lind: 'Methods of structural safety' (Dover Publications, 2006, 1 edn. 2006)
- [21] J. D'Arcy, A. Hovav, and D. Galletta, User awareness of security countermeasures and its impact on information systems misuse: A deterrence approach, *Information Systems Research* 20 (1) (2009) pp. 79-98.
- [22] H.A. Hamid, and NRSM Dali, Curbing misbehavior with information security measures: An empirical evidence from a case study, *AL-'ABQARI: Journal of Islamic Social Sciences and Humanities* 17 (1) (2019) pp. 28-38.
- [23] S. Hina, and P.D.D. Dominic, Information security policies' compliance: a perspective for higher education institutions, *Journal of Computer Information Systems* 1 (March) (2018) pp. 201-211.
- [24] I. Etikan, S.A. Musa, and R.S. Alkassim, Comparison of convenience sampling and purposive sampling, *American journal of Theoretical Applied Statistics* 5 (1) (2016) pp. 1-4.
- [25] B. Williams, A. Onsman, and T. Brown, Exploratory factor analysis: A five-step guide for novices, *Australasian Journal of Paramedicine* 8 (3) (2010) pp. 1-13.
- [26] A. Field: 'Discovering statistics using IBM SPSS statistics: North American edition' (Sage, 2017, 5 edn. 2017)
- [27] M.K. Malhotra, and V. Grover, An assessment of survey research in POM: from constructs to theory, *Journal of Operations Management* 16 (4) (1998) pp. 407-425.

# The Development of Online Training Curriculum Base on Micro Learning and Online Social Network for Teacher in 21<sup>st</sup> Century in Test Construction Topic

<sup>[1]</sup> Ruangdech Sirikit, <sup>[2]</sup> Panwasn Mahalawalert, <sup>[3]</sup> Areeya Sriprasert

<sup>[1][2]</sup> Educational and Psychological Test Bureau, Srinakharinwirot University, Bangkok, Thailand

<sup>[3]</sup> School of Information Technology, Eastern Asia University, Bangkok, Thailand

**Abstract**— The objectives of this research were 1) to develop the online training curriculum based on Micro Learning and Online Social Network for 21st century teachers on test creation, and 2) to evaluate the effectiveness of the online training curriculum based on Micro Learning and Online Social Network for 21st century teachers on test creation. The methodology was divided into 2 steps: Step 1 was the development of the online training curriculum based on Micro Learning and Online Social Network for 21st century teachers on test creation by studying the problems and demands in examination creating including the demand on online training for Bangkok schools' teachers and executives using questionnaires. After that the information data gained from step 1 was used to design and develop the training curriculum then quality checked by the expert. The result found that the developed online training curriculum was in the highest suitability level. Step 2 was the effectiveness evaluation of the online training curriculum based on Micro Learning and Online Social Network for 21st century teachers on test creation by using the developed training curriculum with 30 Bangkok teachers from simple random sampling from the respondents in step 1 and willing to participate in online training on test creation.

The result found that 1) the evaluation on the teachers' test creation ability compared to the ability before and after joining the training from development scores of each trained teacher – 2 teachers (6.67%) performed very high development, 21 teachers (70.00%) performed high development and 7 teachers (23.33%) performed moderate development and 2) the quality evaluation in accordance with the assessment standards of The Joint Committee on Standards for Educational Evaluation which was evaluated by 30 participating teachers and executives of the 30 teachers were in good level for 4 standards. The standard with the highest mean was propriety standards ( $\bar{x} = 4.78$ ). The next one was feasibility standards  $\bar{x} = 4.74$ (, Utility standards)  $\bar{x} = 4.71$  ( and accuracy standards)  $\bar{x} = 4.64$ (, respectively).

**Index Terms**— Training curriculum, Online training curriculum, Micro learning

## I. INTRODUCTION

Presently, the world is in rapid advancement from the use of technology to connect every information together. The social changing trend in the 21<sup>st</sup> century then broadly affects the way of life in the society. Thai society in the past was simple with rarely change with was open and accepted the outside culture to adapt in the environment and way of life. When entering the 21<sup>st</sup> century, Thailand also changes to the World's trend due to the advancement of science, technology and information. The mentioned matters are the important factors for the age of borderless communication. The education development then is essential in order to prepare for the future (Nawapohn Chalaruk, 2015).

Teacher plays the important role in education process as their main task is to perform teaching as well as develop the quality student. Teacher needs to be professional, expert on both academic and modern teaching techniques in accordance with the World's changes in technology and society for the learners to develop Thai society to compete with the global society (Somwang Phithiyauwat. 2000). The desirable features of teachers in the 21<sup>st</sup> century are the

insight knowledge of the subject, teaching expertise, able to develop the courses, lessons and course book planning focusing on the learners, invent the lessons that every learner can learn, allow the learners to learn from knowledge seeking, help the learners to understand the nature of science, math and technology and give the learners the opportunity to develop the motto, skills helping the learners to have sustainable learning. (Upper Secondary Education Bureau, 2014). Therefore, the teacher needs to continuously develop their skills because the quality of the teacher directly affects the students'. The high-quality teacher can greatly provide knowledge to the students.

The ability to create examination is the part of measurement and evaluation performance which is the important performance of the teacher as the examination is the essential tool to evaluate the ability of the students. The information from the examination reflects the quality of education, helps the teacher see the guideline to develop and improve the students including the teaching. Sumreong Boonruengrat (2004) explained that the education evaluation tool helps the teachers, counselors, executives and researchers, acts as the tool to inspect the development

of the students' intelligence, mind and society how much it develops according to the educational target. The result is used to improve or develop the students and education process. This is in accordance with Utumpohn Jamonman (2002) who explained that examination provides the result of students' performance, teachers' teaching, educationist planning and the management of the educational institute. Therefore, the examination is influential on education, students, teachers, executives, people, educational institutes, educational development plans and the country eventually.

The teacher then must not ignore the importance of test creation as Chawan Pearatkul (2009) explained that the teacher has important task to create the better and unique measurement tool for the perfect measurement. The tool can be created in any way to stimulate the students to express the behaviors that the teacher needs to evaluate with the method to measure such behavior. Which examination is better depends on how accurate and suitable the examination points out the effectiveness line. Therefore, the researcher team are interested in developing the online training curriculum for 21st century teachers on test creation by using the lesson focusing on micro learning together with online social network. Micro learning is the gradual learning using small amount of time that can be used with daily routine of working people such as watching 2-3 minute video clip, doing built-in answer quiz or reading short passages. This way can facilitate the participants in term of data accessing, travelling as well as reduce budget in each training in the long term.

## II. AIM

1. To develop the online training curriculum based on Micro Learning and Online Social Network for 21st century teachers on test creation.
2. To evaluate the effectiveness of O online training curriculum based on Micro Learning and Online Social Network for 21st century teachers on test creation.

## III. DEFINITIONS

**Training Curriculum** means a total package of learning activities designed to achieve. the objectives of the training program.

**Online Training** is the distance learning, or e-learning and online training is a form of instruction that takes place completely on the internet. It involves a variety of multimedia elements, including graphics, audio, video, and web-links, which all can be accessed through one's internet browser.

**Micro learning** means small learning units and short-term learning activities. The term is used in e-learning and related fields in the sense of learning processes in mediated environments.

## IV. METHODS

This research aimed to develop the online training curriculum based on Micro Learning and Online Social Network for 21st century teachers on test creation.

The methodology was divided into 2 steps.

**Step 1** was the development of online training curriculum based on Micro Learning and Online Social Network for 21st century teachers on test creation.

1. Study the problems and demands in examination creating including the demand on online training for Bangkok schools' teachers and executives using questionnaires.
2. Design and develop training curriculum using the information from step 1 in the training development.
3. Draft online training curriculum composing of principles, course objectives, structure, training time, content, training activities and measurement and evaluation of training.
4. Review the suitability of the course by the expert.
5. Improve and develop the course.

**Step 2** was the effectiveness evaluation of online training curriculum based on Micro Learning and Online Social Network for 21st century teachers on test creation by using the developed course with 30 Bangkok teachers in the sampling group answering the questionnaire from simple random sampling. The online training was done from December 2019 – February 2020 then the online training curriculum effectiveness evaluation was divided into 2 parts – 1) the evaluation on the teachers' test creation ability compared to the ability before and after joining the training from development scores of each trained teacher and 2) the quality evaluation in accordance with the assessment standards of The Joint Committee on Standards for Educational Evaluation by 30 participating teachers and 30 executives.

## V. RESULTS

This research was the development of the online training curriculum based on Micro Learning and Online Social Network for 21st century teachers on test creation with the result as followed:

1) The development of the online training curriculum based on Micro Learning and Online Social Network for 21st century teachers on test creation.

1.1 The study of problem and demand of teacher on creating examination and participating in online training by using face validity test from the expert and gather the data from the teachers and executives in Bangkok from the simple randomization in 50 districts of Bangkok, 1 school per district. After that 10 of teachers and executives from each school were randomized for total 500. It was found that 462 participants (92.4%) were interested in test creation training and 357 participants (71.4%) were interested in joining online training. However, 116

participants were uncertain if they could participate in scheduled online training. Therefore, 241 participants (42.8%) were interested on participating in online training on test creation and were certain about their participation.

1.2 The researcher team have drafted the online curriculum by presenting the information from step 1 with the curriculum development then created online training curriculum composing of main objective, structure, duration, content, training activity and measurement and training evaluation.

1.3 The inspection of online training curriculum suitability by the expert found that the concordance index was between .80 to 1.00 and in the highest suitability level.

2) The evaluation of the effectiveness of online training curriculum based on Micro Learning and Online Social Network for 21st century teachers on test creation.

1.1 The evaluation on the teachers' test creation ability compared to the ability before and after joining the training from development scores of each trained teacher – 2 teachers (6.67%) performed very high development, 21 teachers (70.00%) performed high development and 7

teachers (23.33%) performed moderate development as shown in table 1.

**Table 1 Number and percentage of teachers participating online training with developmental scores after receiving training, classified by development level.**

Relative Gain Score	Development level	No. of teachers	Percentage
76 - 100	Very high	2	6.67
51-75	High	21	70.00
26-50	Moderate	7	23.33
0-25	Low	-	-
		30	100

1.2 The quality evaluation in accordance with the assessment standards of The Joint Committee on Standards for Educational Evaluation which was evaluated by 30 participating teachers and executives of the 30 teachers were in good level for 4 standards. The standard with the highest mean was propriety standards ( $\bar{x} = 4.78$ ). The next one was feasibility standards ( $\bar{x} = 4.74$ ), Utility standards ( $\bar{x} = 4.71$ ) and accuracy standards ( $\bar{x} = 4.64$ ), respectively. As shown in table 2.

**Table 2 Mean and standard deviation of online training on test creation quality evaluation**

Items	Teachers			Executives			Total		
	$\bar{x}$	S.D.	Interpret	$\bar{x}$	S.D.	Interpret	$\bar{x}$	S.D.	Interpret
1. Utility standards	4.71	0.23	Good	4.19	0.24	Good	4.45	0.21	Good
2. Feasibility standards	4.74	0.17	Good	4.23	0.26	Good	4.48	0.24	Good
3. Propriety standards	4.78	0.15	Very good	4.36	0.20	Good	4.57	0.23	Very good
4. Accuracy standards	4.64	0.22	Very good	3.99	0.28	Good	4.31	0.27	Good

## VI. DISCUSSION

The research results revealed that the evaluation on the teachers' test creation ability compared to the ability before and after joining the training from development scores of each trained teacher – 2 teachers (6.67%) performed very high development, 21 teachers (70.00%) performed high development and 7 teachers (23.33%) performed moderate development consistent with the research of Soraya (2010) showed that development of an online learning, there were significant differences between learners' pretest and posttest at .05 level. For the quality evaluation in accordance with the assessment standards of The Joint Committee on Standards for Educational Evaluation which was evaluated by 30 participating teachers and executives of the 30 teachers were in good level for 4 standards. The standard with the highest mean was propriety standards ( $\bar{x} = 4.78$ ). The next one was feasibility standards ( $\bar{x} = 4.74$ ), Utility standards ( $\bar{x} = 4.71$ ) and accuracy standards ( $\bar{x} = 4.64$ ) consistent with the research of Phusit (2012) presented that the strategy for promoting self-regulated learning strategies in online context composed of video, studying paper, voice, assignment, web-board, online chatting and social network have affects the level of their

self-regulated learning strategies and the learning achievement at statistical significance.

### Suggestions

Recommendation for applications

1. The interest parties should study online training curriculum to be able to arrange the complete training according to the content.
2. Since it is online training curriculum, the constant communication with the participation is needed to create the inspiration in the course.
3. As the ability to create examination is the skill from practicing, those who are interested need to stimulate the participants to practice creating and commenting the examination for the mutual learning.

Recommendations for the next research

1. The training period and result follow up after the training should be added to develop the further training curriculum.
2. There should be other online curriculums to help reduce the training budget, increase data accessibility for the participants, reduce travel burden and able to manage training duration by themselves.



**Acknowledgment**

The author is very grateful to Srinakharinwirot University (www.swu.ac.th) for encouragement and supporting.

10.13189/ujer.2020.082504DOI:10.13189/ujer.2020.080242

**REFERENCES**

- [1] Chawan Pearatkul (2009). *Assessment technique*. 7<sup>th</sup> edition. Bangkok. Vitoon Binding & Printing.
- [2] Nawapohn Chalaruk (2015). "Role of teacher and 21<sup>st</sup> century education". Far Eastern University academic journal Year 9 Vol 1 (May-July) : 64-71
- [3] Mac Education. (2014). *Teacher of 1<sup>st</sup> century*. Bangkok : Plan Printing Co., Ltd.
- [4] Passakorn Ruangrong et al. (2014). "Education technology and Thai teacher in 21<sup>st</sup> century". Panyapiwat Journal. Year 5. Special edition (May) : 195-207  
[http://www.rand.org/pubs/research\\_briefs/2005/RAN\\_D\\_RB9050.pdf](http://www.rand.org/pubs/research_briefs/2005/RAN_D_RB9050.pdf)
- [5] Upper Secondary Education Bureau, Office of the Basic Education Commission. (2014). *Guideline for education in 21<sup>st</sup> century*. Bangkok : The Agricultural Cooperative Federation of Thailand. Limited.
- [6] Sirichai Garnchanawasri. (2009). *Traditional examination theory*. 6<sup>th</sup> edition. Bangkok : Chulalongkorn University Printing House.
- [7] Somwang Piiyanuwat. (2014). Training documentation "Developing test construction and examination guidelines". Bangkok : Vajirawut Witthayalai School.
- [8] Sumroeng Boonruangrit et al. (2004 ). *Educational Measurement and Evaluation: 3<sup>rd</sup> Specific Encyclopedia of Education*. Educational Measurement and Evaluation Program. Encyclopedia of Education. Bangkok : Copy and Print.
- [9] Utumpohn Chamonman. (2002). *Examination: Creation and Development*. Bangkok. Funny Publishing.
- [10] Soraya Sarasuphab. (2010). *Development of an online social network learning model utilizing situate learning theory to enhance intercultural awareness of foreign language learners*. Doctoral Thesis, Department of Educational Research and Psychology, Graduate School, Chulalongkorn University.
- [11] Phusit Wonglorsaichon. (2012). *Research and development of a strategy manual for promoting self-regulated learning strategies in online context of university students with a data collection design through online system*. Doctoral Thesis, Department of Educational Research and Psychology, Graduate School, Chulalongkorn University.
- [12] Retni S. B. and Harlis, D. N. (2020). High Order Thinking Skills for Biology Education: Applied Microbiology Learning Videos Based on Jambi Local Wisdom. *Universal Journal of Educational Research* 8(2): 689-694, DOI:

# Macro Based Malware Detection System

<sup>[1]</sup> Balal Sohail, <sup>[2]</sup> Ma'en Tayseer Ekrayem Alrashd, <sup>[3]</sup> Yaseein Soubhi Hussein, <sup>[4]</sup> Mohammad Tubishat, <sup>[5]</sup> Shounak Ghosh, <sup>[6]</sup> Ahmed Saeed Alabed

<sup>[1][2][4]</sup> Asia Pacific University of Technology & Innovation, Kuala Lumpur, Malaysia

<sup>[3][6]</sup> Department of Information Systems and Computer Science, Ahmed Bin Mohammed Military College, Qatar

Email: <sup>[1]</sup> balalsohail007@gmail.com, <sup>[2]</sup> dr.maen@apu.edu.my, <sup>[3]</sup> dr.yaseein@abmmc.edu.qa,

<sup>[4]</sup> tubishat@staffemail.apu.edu.my, <sup>[5]</sup> shawn@apu.edu.my, <sup>[6]</sup> ahmed.alabed@abmmc.edu.qa

**Abstract**— Macro based Malware has taken a great rise in these recent years, Attackers are now using this malware for hacking purposes. This virus is embedded inside the macro of a word document and can be used to infect the victim's machine. These infected files are usually sent through emails and all antivirus software are unable to detect the virus due to the format of the file. Due to the format being a rich text file and not an executable file, the infected file is able to bypass all security. Hence it is necessary to develop a detection system for such attacks to help reduce the threat.

Technical research is carried out to identify the tools and techniques essential in the completion of this system. Research on methodology is done to finalise which development cycle will be used and how functions will be carried out at each phase of the development cycle. This paper outlines the problems that people face once they are attacked through macro malwares and the way it can be mitigated. Lastly, all information necessary to start the implementation has been gathered and analysed.

**Index Terms**—malware detection, Malicious, Macros, Attack, Office

## I. INTRODUCTION

As technology and internet gained rise in the last decade, it has offered and delivered several benefits to all kinds of industry or organizations. With the help of technology several processes have been automated in today's time which provides efficiency and enhanced productivity (Cunningham, P. *et al.*, 2018). On the other hand, the usage of internet boosted rapidly to the extent that everyone nowadays uses the internet.

With internet came several benefits such as quick research, cloud computing, Electronic mail and several more but all these benefits gave rise to more online attacks such as social engineering, man-in-the-middle attack, hacking and most importantly, malware attacks.

Malware is a software that is designed by attackers with a malicious intent of stealing private and confidential information, causing harm or damaging the device or any software in the victim's machine. Most of the time a malware is created by a group of hackers who are trying to find a way to make money either by spreading malware themselves and then asking for ransom such as the famous ransomware or by creating a malware and selling it to the highest bidder on the dark web.

Malware has been out there since the late 1980's but most malware programs at that time were simple boot sector and file infectors that were spread via floppy disk. As technology advanced and got standardized, most of the malwares proliferated yet macro malwares gained sudden boost. A macro malware is used to spread virus by taking advantage of the Visual Basic for Applications (VBA) programming in Microsoft Office macros. This virus has been used since the 1990s. Due to the emergence of

complex social engineering attacks, macro malware poses a real threat to personal and organization's security.

Research has been done on related works of other researchers to better understand the threat and to get familiar with ideas of how to mitigate this attack. Several research papers have been studied to get an in-depth understanding. Based on the research conducted, the method for how to detect malware in these files was decided. Datasets will be created which would contain data and signatures of several files. Once the signature of the infected file will be extracted, it will be matched to the signatures saved to rate the file as infected or benign.

Recently, macro malware has gained extreme popularity as it is the only way to spread malware while surpassing all antivirus software and firewalls. Attackers are now using emails as the main mean of spreading macro malware. All antivirus software can detect executable files as attachments to emails and block them hence making the attacker's attempt unsuccessful. With macro malware since it is embedded inside a word document, it is identified as a normal rich text file and that is why it can surpass all security measures.

To mitigate this attack, several systems and search engines have been developed such as VirusTotal to detect such files, yet this attack seems to excel. Hence, a macro malware detection system is to be developed in this project to automatically detect and analyse such macro embedded Microsoft Word files.

The main purpose of this paper is to develop and evaluate a system to detect macro malware which are embedded inside Microsoft Word document macros and can go undetected due to the nature of the file being non-executable. The main contributions of this paper are:

- To investigate and analyse the existing anti-virus software for macro malware detection.
- To design a framework to detect macro based malware.
- To develop a detection system based on the proposed framework for Microsoft Word documents.
- To increase the level of security and protection against macro attacks.
- To evaluate and test developed system to ensure its accuracy.

II. LITERATURE REVIEW

In this section, we will discuss the related works of different ways of spreading the malware, such as Macro Malware, Spam Email and Phishing Email.

Macro Malware:

Cyber-attacks aimed at organizations have increased drastically whereas in 2013, 91% of the organizations were hit by cyber-attacks. According to (Cohen *et al.*, 2016) and (Ucci, Aniello and Baldoni, 2019), email has become the main platform to execute such attacks as majority of the organizations rely on email to be the main means of internal and external communication. Non-executable files such as Microsoft Office documents attached to emails have been the basis of several recent cyber-attacks. Attackers can embed a malicious code inside these documents. The author further points out that there is several anti-virus software that can scan and filter any sort of executable files attached to emails, yet they fail here as to the non-executable nature of the documents. Hence, this study presents a novel structural feature extraction methodology (Cohen *et al.*, 2016) for Microsoft Word based documents. This methodology makes use of the hierarchical nature of office documents to convert them into unique paths as each path represents the file’s properties and actions. Figure 1 below shows how these paths look like:

```
[Document Folder]\[Content_Types].xml
[Document Folder]\docProps
[Document Folder]\docProps\app.xml
[Document Folder]\docProps\core.xml
[Document Folder]\word
[Document Folder]\word\comments.xml
[Document Folder]\word\commentsExtended.xml
[Document Folder]\word\document.xml
[Document Folder]\word\fontTable.xml
[Document Folder]\word\numbering.xml
[Document Folder]\word\people.xml
[Document Folder]\word\settings.xml
[Document Folder]\word\styles.xml
[Document Folder]\word\webSettings.xml
[Document Folder]\_rels
[Document Folder]\_rels\rels
[Document Folder]\word\media
[Document Folder]\word\media\image1.png
[Document Folder]\word\theme
[Document Folder]\word\theme\theme1.xml
[Document Folder]\_rels
[Document Folder]\word\_rels\document.xml.rels
```

Figure 1. Demonstration of file paths

Moving on a java library has been used to scan all the available paths. During scanning, this methodology yields a set of unique features that have been extracted along with

their occurrences in a specific document. Then the most unique feature will be selected, and a training set is built which is then used in training the machine learning classifiers. Different datasets are created, and the results are evaluated accordingly.

Attackers these days have changed their attack vector from operating system level to application level and that is why most attackers now are concentrating on finding vulnerabilities in common office applications like Microsoft Word. (Schreck, Berger and Göbel, 2013) from Siemens in 2013 presented a new approach called Binary Instrumentation System for Secure Analysis of Malicious Documents (Schreck, Berger and Göbel, 2013). This approach consists of three purposes including distinguishing malicious documents from benign documents, extracting malicious embedded shellcode in the malicious documents and detecting and identifying the vulnerability exploited by the malicious document. This approach automatically determines the vulnerability that is targeted by the code. The vulnerability can either be for which a patch already exists as well as a new security flaw that has recently been identified. Hence, this approach helps to remedy the vulnerability by installing the correct patch if it exists. According to (Daryabar, F. *et al.*, 2011) embedded malware is one of the effective ways to bypass an anti-virus gateway. Once the malware is added into documents or other files, the chances for it to be discovered decrease radically. Microsoft Word documents allow several executable files to be attached as objects and that is how they reach the victims system. As soon as the victim opens the file or clicks on this object, the malware is executed. Figure 2 shows the percentage of malwares that bypassed an anti-virus via Microsoft Word documents.

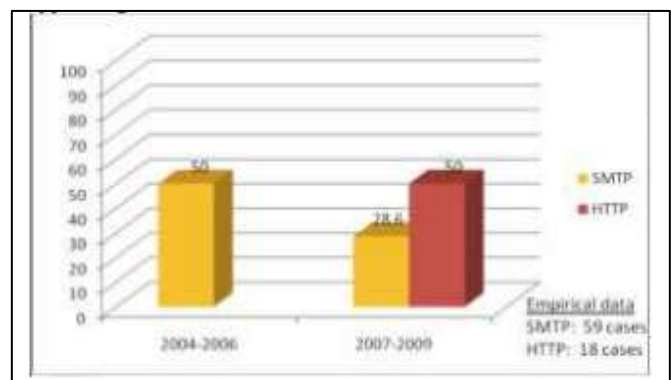

Figure 2. Percentage of Malware that bypassed an anti-virus via MS Word documents (Ding, L., *et al.*, 2014)

The proposed solution to such attacks is to implement a honeypot system which requires three different levels of honeypot with each honeypot having its own role and responsibilities. The first layer is to be considered as an Intrusion Detection system (IDS) which will check the data received, whether executable or not and files received from external parties. This layer will run the received files to

capture the activities and behaviour for further use. The second layer checks the data and the running processes using an anti-virus. If a known virus is detected at this layer, it will be stopped from entering the network and if no virus is detected, the data will be categorized as a new malware. The final layer will then delete the malicious code making the system or network secure. Figure 3 below shows a proposed design on this system.

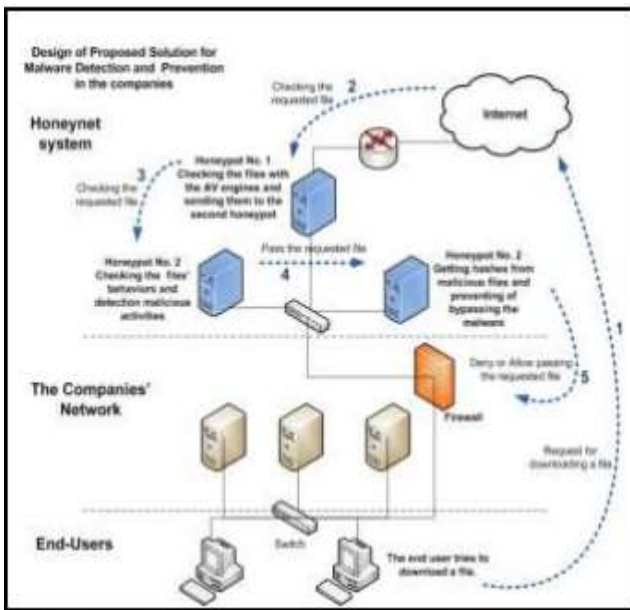

Figure 3 Proposed Design

Bradley (2018) also believes that macro-based threats are mostly spread via email campaigns where the malware is included as an attachment to the email. Attackers choose to use this method because the malware can be hidden behind layers of data making it difficult for anti-virus engines to detect it. One of the famous macro-based malwares is Adnel that downloads the runs files on the computer as soon as the infected file is open. According to Bradley (2018) the first step to prevent such attacks is to design an effective email security policy that would include training the employees so that they would not open or download malicious attachments that come from unknown sources. It is extremely important to spread awareness of some common cyber-attacks so that the employees are not manipulated easily. Furthermore, any word document by default has macro disabled yet there are malwares that can make the user do a different task that would automatically enable macro in that document hence, training would be a good way to prevent such careless mistakes. Besides training, sanitizing files through file type conversion or any other method is a good way to strip out any potentially dangerous macro while leaving behind the benign content on the file. This technique will help block known and unknown macros from entering.

**Spam Email:**

Spam is data intended to be sent to a huge group of individuals without them wanting to, whereby a spam

channel is an automated instrument to recognize spam to guarantee greater profitability of the client (Cormack, 2008). As indicated by Jorgensen, Zhou and Inge (2008), assaults on spam channels have become a significantly greater test for the counter spam network. In light of their examination a 'good word assault' is the most successive spamming system utilized by spammers and the most ideal approach to counter it is through a guard procedure utilizing various case learning that has indicated extraordinary precision based on all the tests led by them. A decent word assault is the utilization of words, that are a piece of authentic messages (Jorgensen, Zhou and Inge, 2007).

As per Basavaraju and Prabhakar (2010), there is another method of utilizing content bunching dependent on vector space model which separates the spam/non spam messages and recognize spam messages all the more productively by examining designs. This procedure works by isolating the information into bunches with comparative examples. As indicated by (Cunningham et al., 2004), a case-based way to deal with spam sifting beats Naive Bayes as it binds together substance based and cooperative methodologies. In their exploration synergistic methodology alludes to all the clients teaming up for example, in the event that one of them gets a spam, he will share the hash mark of that email with the rest which will make mindfulness for that email. In the light of the examination done, a case-based methodology appears the most ideal approach to channel spam messages in such a case that it has been identified by a client and made open to public.

No spam channel is sheltered, as Lowd and Meek (2014) and Robert and Kolcz (2020) accept that any great word assault can bring about half of the right now blocked spam to go past through any channel as no suspicious words are utilized to be recognized by the channel and subsequently the main cure is to constrain the harm they can cause. This method is powerful, however, it requires steady updates to coordinate with all the new words being utilized by the aggressors which is tedious and requires persistent exertion. Email spam is probably the most concerning issue nowadays causing enormous monetary loses to associations and irritating the people and they over flood the email accounts that outcomes in significant messages being ignored.

There are several studies and researches available that mark macro malware as one of the most stealth ways to deliver a malware to the victim. Most anti-virus software scan executable files to look for viruses whereas since macro malware is embedded inside Office Documents hence it can go undetected. Due to its nature it can also go around Gmail security making it extremely easy for attackers to send macro infected files to their victims through emails. According to a study, Microsoft macros is still the top vector for malware delivery. In the third quarter of 2018, 45% of the malwares were delivered using Microsoft macros (Seals, 2018). These macro scripts can carry any kind of malware ranging from a simple worm or a Trojan horse up to malwares like ransomware that caused so much



of damage to several major companies in 2019. Although macro in any Office Documents are disabled by default but there are macro scripts written which can automatically enable the macro on the victim's machine as soon as the file is opened. These malicious scripts embedded inside Office Documents can be executed either when the file is opened or if any hyperlink in form of a text or picture is clicked inside the document (Brook, 2018). Malware does not spread unless the file is opened hence simply downloading it on to your machine is not harmful at all.

Most of the people easily fall prey to such attacks as it is very hard to identify the attack. Macro infected files are mostly sent through phishing and spam email making them look like a legitimate email provoking the victim to download and open the file. Most of the people out there are not aware of macro malwares which is why no precaution is taken by them while downloading and opening these files from unknown sources. Most people think that having an anti-virus is enough to prevent against hacking, but it is not. Attackers evolve as technology advances and they come up with new ways to hack, ways that were unknown to the world.

The Macro Based Malware Detection System is a desktop application that has been developed for detecting macro scripts in infected Office Documents. The main aim of the project was to only focus on Microsoft Word Documents, but later enhancements were made to the system and more formats were added such as Microsoft Excel and Microsoft PowerPoint files.

The developed system provides countless benefits to the users. Firstly, unlike other anti-virus that are unable to detect macro malware, the developed system has unparalleled accuracy to detect macro infected files. This would help the user to effectively detect malicious files to avoid falling prey to such attacks. Efficient detection of malicious files would ensure the safety of user data and hardware as well as data privacy and confidentiality. User's will not have to face the agony of their files being deleted, or the system getting super slow, or their files being encrypted along with a ransom demand etc.

Secondly, the developed system not only detects macro scripts in files but produces a detailed result regarding as to why a file has been marked as malicious. This will benefit security experts, lecturers and students of the related field to analyse the results to better understand the nature of these malwares and how they work.

Thirdly, the system has been developed to cater to all kinds of users specially novice users which is why the interface of the system was designed to be simple and user-friendly. This system will also help generate and create awareness amongst people regarding macro malwares which might result in people taking this threat seriously and making it hard for the attackers to hack using this method.

### **Phishing Email:**

Phishing assaults involve authentic looking messages from genuine associations that threaten the client to enter in their private data. When the client enters this data, it is legitimately sent to the assailants who have started this assault. Fette et al., (2006) presented pilfer which is an artificial intelligence (AI) based methodology for grouping messages dependent on whether they are authentic messages or non-genuine messages. Recently, scientists had the option to get high exactness with just ten highlights incorporated into the framework (Wombat Security, a., 2018) . In addition, since assailants can change strategy, this channel can without much of a stretch adjust to the new highlights added to its classifier. What's more, phishing assaults undermine client trust in the legitimacy of messages and dependent on an exploration directed in April 2004, a colossal populace in America succumbed to these phishing assaults which cost the banks and organizations about 1.2 billion dollars in misfortune (Litan, 2004).

Chang et al. (2008) took a couple of highlights which to them were of most extreme significance when distinguishing phishing messages. Thorough testing was done on all highlights and progressions were made whereby two new highlights were presented DMZ (Dynamic Markov Chains) which decreases the memory necessities by two third and CLTOM (Class-Topic Models) include that joins class-explicit data into the point model. Classifiers with these highlights beat past methodologies. As per (San Martino and Perramon, 2011), a multifaceted confirmation framework will help against phishing assaults as it will check the computerized marks of the two gatherings followed by an asymmetric encryption applied to all data being shared between two substances which will guarantee that the data is protected and must be decoded utilizing a common key. This proposed framework will likewise give discovery against malwares and infections on the customer side to thoroughly make sure about the client's gadget as an assailant can utilize the client's gadget to hack into the association system or server. These highlights make this examination incredibly effective as having an awry encryption upgrades the security by an indent followed by an in-fabricated enemy of infection.

Rule-based phishing assault strategy involves fifteen guidelines which were created after an exceptionally broad research on website pages, perceptions led and dependent on AI highlights proposed in different looks into. These guidelines are then utilized in Decision Tree alongside Logistic Regression learning calculations to recognize whether a page is real or a phishing trick subsequently utilizing guess procedure to arrive at a resolution (Basnet et al., 2012). It tends to be gotten from this examination paper that a multifaceted verification is most reasonable strategy to counter a phishing assault, as referenced by San Martino and Perramon (2011). Lopsided encryption utilizes an open key and a private key to unscramble so regardless of whether data is lost or taken. It cannot be decoded without a private key which makes it of no worth yet making sure

about the safety of the private key is another crucial component.

### III. MATERIALS AND METHODS

**In this section, we will present a justification on the most suitable language for developing this system.**

#### 3.1 Programming Language Chosen

Python was created by Guido van Rossum in 1991. Python is an interpreted, general purpose, high level language and its design emphasizes code readability as it uses significant whitespace. Its object-oriented approach helps the programmers to write codes that are logical and clear regardless of the size of the project. Python supports multiple programming paradigms such as functional programming, object-oriented and functional programming. It is dynamically typed and has an extremely comprehensive library (Rongala, 2015).

Python interpreters are available for several operating systems. The greatest strength of python stems from the large library that provides countless tools suitable for several tasks. It includes areas like web services tools, string operations, internet protocols and operating system interfaces. Several programming tasks have been scripted inside this library hence there is no need to write the whole code as these scripts can simply be called as functions or imported as libraries. The official repository for third-party software contains more than 200,000 packages such as graphical user interfaces, web frameworks, multimedia, databases etc. Python is easy to learn and has vast available resources to provide support. It is extremely user-friendly. Lastly, python has several libraries that can be used to analyse data and for DE obfuscating macros (Chou, 2019).

**Table 3.1.1 Comparison between JavaScript and Python**

	JavaScript	Python
<b>Type</b>	Object oriented	Object oriented high-level programming language
<b>Static Typing</b>	Dynamic	Dynamic
<b>Platform</b>	Cross-platform compatible	Cross-platform compatible
<b>Community Support</b>	Easy to find tutorials	Has large support
<b>Development Speed</b>	Moderate	Fast
<b>Capabilities in System Development</b>	For stand-alone systems	For stand-alone systems
<b>Learning Curve</b>	More complex and hardcore skills needed.	No hardcore skills are needed

When comparing with other languages python has a better and a faster execution speed compared to Java or R which would improve the overall productivity of the system. Python and Java both are used for building stand-alone

systems, yet python does not require hardcore coding skills making it a preferred choice when compared to other languages.

Therefore, based on all the reasons mentioned above, python has been chosen as the most suitable language for developing this system.

#### 3.2 IDE (Interactive Development Environment)

PyCharm is a framework that has been designed by programmers to allow other programmers with all the tools necessary for a productive Python development. PyCharm allows programmers to write neat codes as it helps control the quality with PEP8 checks, smart refactoring and testing assistance (Aditya Sharma, 2019). PEP8 checks highlight any coding violations and give suggestions instantly as you type. It provides intelligent python assistance with code inspections, error highlighting and quick fixes to make development easier. Furthermore, it offers great framework support for modern web development. Apart from integrated with scientific tools, PyCharm also supports other programming languages such as JavaScript, Cython, SQL etc. to allow cross-technology development. Lastly, PyCharm provides numerous features built-in developer tools such as an integrated debugger, test runner, python profiler, built-in terminal (Sharma,A., 2019) .

Compared to other IDE's PyCharm is the most suitable as it compromises of several functions such as run configuration, remote debugging etc, which cannot be found in other frameworks. PyCharm supports the greatest number of frameworks when compared to Visual Studio and Eclipse. Therefore, PyCharm has been chosen as the most suitable IDE to develop this system.

#### 3.3 Libraries/Tools chosen

##### Olevba:

Olevba is a script to analyse OLE and XML files such as Microsoft Office documents to detect VBA Macros, extract them, detect patterns such as executable files or keywords and potential IOCs. Moreover, it detects and decodes obfuscation methods as well including Base64, Dridex, Hex encoding etc. It is a part of python oletools package.

It supports several formats such as Word 97-2003, Word 2007+ (.docm), Excel 97-2003 (.xls), Excel 2007+ (.xlsm), PowerPoint 97-2003 (.ppt) and PowerPoint 2007+ (.pptm). Different versions of each program cater to different file extensions. Its main features include detecting VBA Macros, extracting macros, detect auto-executable macros, detect suspicious keywords, extract IOCs and scan all of them to check whether they are malicious or not.

Olevba works by checking the file type to ensure that the file type is supported by this package. Next, it identifies all VBA projects and each project is analysed to find its corresponding OLE stream which contains the macro code. The code is then extracted and compressed and the it

checked for specific strings, algorithms, executable files, specific keywords etc.(Pippi, G., 2020).

**Class:**

- **VBA\_parser:** This class is used to parse the files once the name of the file is provided to open as a parameter.
- **VBA\_scanner:** This class is used to scan the source code to find strings, keywords etc. The scan results consist of a list of tuples containing type, keywords, descriptions etc.

**Methods:**

- **Detect\_vba\_macros:** This is a method that returns true if macros have been found in the chosen file.
- **Extract\_macros:** This is a method that extracts the source code for each macro found in the file. It functions as a generator yielding a tuple for each macro found.
- **Analyze\_macros:** This is a method to scan the source code to find obfuscated strings, suspicious keywords, IOCs, auto-executable files etc.

**Functions:**

- **Detect\_autoexec:** This function is used to check whether the macro code contains such code that can be triggered if the document is open or if something is clicked inside the document. It returns a list containing the detected keyword and the description of the triggered identified.
- **Detect\_suspicious:** This function is to check whether the macro code contains specific keywords that are often used by attackers to design malwares or viruses. It returns the detected keyword and its description.
- **Detect\_patterns:** This function checks the macro code for containing specific patterns that maybe useful when analysing the malware and its detection. It returns the pattern type and the extracted value.

**3.4 Operating System Chosen**

An Operating System provides the users with a user interface to use the hardware and software. In this paper Windows 10 by Microsoft is selected to be the chosen operating system.

Windows follow a directory structure to store files. Windows has very less restrictions and allows third party applications to be installed as well compared to Mac operating system (macOS). Windows can support a vast number of tools in the operating system(Grabham, 2019). Moreover, Windows is the most used operating system as all offices and organizations mostly use Windows as it has an easy user interface to interact with. Any devices can be easily connected to Windows as compared to macOS that requires Apple products to run. On the other hand, Linux has very less features and it is complicated to use. Lastly,

NetBeans is fully supported by Windows Operating System.

**IV. RESULTS AND DISCUSSION**

The macro malware detection system will allow users to stay protected against such malware attacks. It will detect files with macro malware to prevent the malware from being deployed successfully. These malicious files will be marked as malicious only after being compared with a dataset. Signatures of several files and several macro scripts will be used to create these datasets and then characteristics of the test file will be compared with the signatures inside the datasets. Once detected the system will inform the users about the presence of a malware which would help users and their files to be safe and not be infected by this malware.

**4.1 User Acceptance Testing Result Analysis**

Interface Design

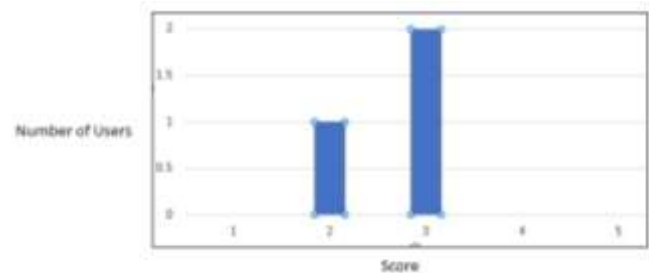

**Figure 4 Interface Design UAT results**

Figure 4 illustrates the results of the UAT regarding the interface design of the developed system. There are two users that gave a score of 3 which stands for average whereby 1 user gave a score of 2. These results show that the interface can be improved and should be improved to make it more attractive.

Figure 5 illustrates the results of UAT regarding objectives being met by developing the project. 2 users gave a score of 5 that means that they are extremely happy with the functionality of the system whereas 1 user gave a score of 4. Thus, the users are extremely satisfied with the functionality of the system as it meets the project objectives.

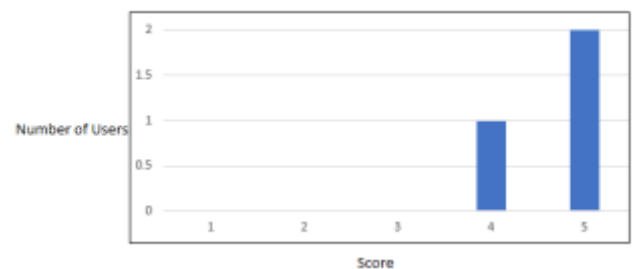

**Figure 5 Meeting Objective UAT results**

Figure 6 illustrates the UAT testing results for system validation. We found that there are two users gave a score of 5 and 1 user gave a score of 4. Thus, users are fully satisfied with the system as it exactly functions how it is supposed to and as expected by the users. It is extremely accurate and highly precise when detecting macro scripts which is a huge positive point for the developer and the system.

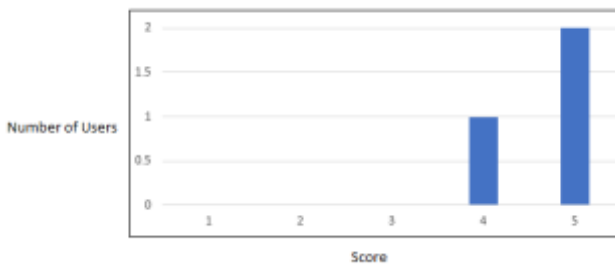

Figure 6 System Validation UAT results

Figure 7 illustrates the results of UAT maintainability testing. All 3 users gave a score of 4, hence the users are quite satisfied with the maintainability of the system. As a system equipped with a simple GUI, consequently to maintain it and overcoming failures will relatively be easier.

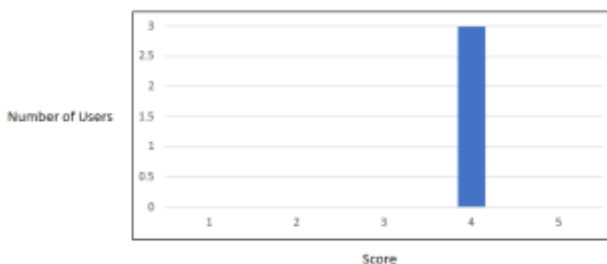

Figure 7 Maintainability UAT results

Figure 8 illustrates the results of UAT Free from bugs test. There are two users gave a score of 5 and 1 user gave a score of 4. These results are considered extraordinary meaning that the users are satisfied with the system as there are so visible or existing bugs in the system and it is functioning perfectly according to the proposed method.

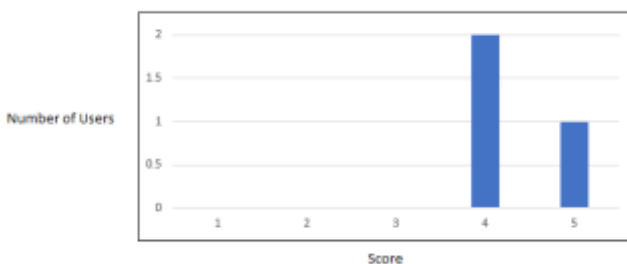

Figure 8 Free from Bugs UAT results

The feedback received from the users was extremely satisfactory. There were several recommendations given by the users such as:

- The result should also show the file path and file type of each tested file to avoid confusions.
- The interface should inform the user regarding which file is being tested if the user has uploaded multiple files to be checked at the same time.
- When multiple files are being tested at the same time, results of all files are saved in one file too, but the result of each file should be properly segregated to avoid confusion as to which result is for which file.

All recommendations were taken into consideration and changes were made to the system to further make the system user-friendly.

V. CONCLUSION

In conclusion, several types of tests were conducted on the developed system to validate the system and to locate errors or bugs in the system. Testing was done for all functions of the system to ensure that everything is functioning properly. Secondly, accuracy testing was conducted to test the authenticity of the system for which a file pool of 50 files per format was created and tested with VirusTotal and the developed system. Lastly, user acceptance testing was done in which 3 users were given the system to use and their feedback was recorded. Based on the analysis of the feedback, all 3 users overall were satisfied with the system in terms of interface, meeting the objectives, maintainability, validation and no bugs. The users also suggested a few recommendations that can be applied to the system which would further improve it.

Moreover, macro malware is a major issue of this era where technology is growing rapidly yet the developed system will hopefully contribute a lot in staying secure from such possible attacks. The developed system is extremely accurate in detecting macro for a few file formats making it hard for the attackers to execute these macro malware scripts. Hence, the developed system is successful in solving the problem of malwares going undetected by being embedded inside Office Documents.

Whereas, the developed system is very accurate in detecting macros in files, but like any other system, it has certain limitations. The developed system can only detect macro in three file formats including Word, Excel and PowerPoint files. This makes the functional of the system limited as macro malwares can also be delivered using several other file formats such as pdf or jpeg files.

The most important future enhancement is to modify the system so that it can check and detect macros in several formats especially the ones that have not been added yet. In future research directions, AI can be used to make a customer inference engine that will help detect macro scripts based on keywords, shell commands etc. The current



system is using a pre-developed library, but using AI, a more extensive system can be developed. While, real-time scanning can be added to the system like every other anti-virus software to scan a few files automatically being saved on the system so that the user does not have to upload the check the file manually.

## REFERENCES

- [1] Aditya Sharma (2019) *Top Python IDEs for 2019 (article)* - DataCamp. Available at: <https://www.datacamp.com/community/tutorials/top-python-ides-for-2019> (Accessed: 13 February 2020).
- [2] Baker, S. E. and Edwards, R. (no date) How many qualitative interviews is enough? Expert voices and early career reflections on sampling and cases in qualitative research. Available at: [http://eprints.ncrm.ac.uk/2273/4/how\\_many\\_interview\\_s.pdf](http://eprints.ncrm.ac.uk/2273/4/how_many_interview_s.pdf) (Accessed: 8 January 2019).
- [3] Basavaraju, M. and Prabhakar, R. (2010) 'A Novel Method of Spam Mail Detection using Text Based Clustering Approach', *International Journal*, 5(4), pp. 15–25. doi: 10.5120/906-1283.
- [4] Basnet, R. et al. (2012) Rule-Based Phishing Attack Detection Kattis View project Phishing View project Rule-Based Phishing Attack Detection. Available at: <https://www.researchgate.net/publication/265919217> (Accessed: 15 December 2018).
- [5] Bradley, T. (2018) *Introduction to Intrusion Detection Systems (IDS)*. Available at: <https://www.lifewire.com/introduction-to-intrusion-detection-systems-ids-2486799> (Accessed: 23 January 2019).
- [6] Branson, T. (2019) *8 Major Advantages of Using MySQL*. Available at: <https://www.datamation.com/storage/8-major-advantages-of-using-mysql.html> (Accessed: 13 October 2019).
- [7] Chang, J. H. et al. (2008) Improved Phishing Detection using Model-Based Features. Improved Phishing Detection using Model-Based Features. Available at: <http://www.webcallerid.net> (Accessed: 15 December 2018).
- [8] Cohen, A. et al. (2016) 'SFEM: Structural feature extraction methodology for the detection of malicious office documents using office learning methods', *Expert Systems with Applications*. Elsevier Ltd, 63, pp. 324–343. doi: 10.1016/j.eswa.2016.07.010.
- [9] Cormack, G. V. (2008) Email Spam Filtering: A Systematic Review, Foundations and Trends® in Information Retrieval. doi: 10.1561/15000000006.
- [10] Cunningham, P. et al. (2018) *A Case-Based Approach to Spam Filtering that Can Track Concept Drift*. Available at: [www.detrirus.org/spam/skit.html](http://www.detrirus.org/spam/skit.html) (Accessed: 15 December 2018).
- [11] Ding, L., Wei, R. and Che, H., 2014. Development of a BIM-based Automated Construction System. *Procedia Engineering*, 85, pp.123-131.
- [12] Daryabar, F., Dehghantanha, A. and Ghasem Broujerdi, H. (2011) *Investigation of Malware Defence and Detection Techniques*. Available at: <http://citeseerx.ist.psu.edu/viewdoc/download?doi=10.1.1.967.6837&rep=rep1&type=pdf> (Accessed: 6 August 2019).
- [13] Drumond, C. (2019) *Scrum - what it is, how it works, and why it's awesome*. Available at: <https://www.atlassian.com/agile/scrum> (Accessed: 13 October 2019).
- [14] Fette Norman Sadeh Anthony Tomic, I. et al. (2006) *Learning to Detect Phishing Emails*. Available at: <https://apps.dtic.mil/dtic/tr/fulltext/u2/a456046.pdf> (Accessed: 11 December 2018).
- [15] Global spam volume as percentage of total e-mail traffic from January 2014 to March 2018, m. (2018). Spam statistics: spam e-mail traffic share 2018 | Statista. [online] Statista. Available at: <https://www.statista.com/statistics/420391/spam-email-traffic-share/> [Accessed 3 Dec. 2018].
- [16] Grabham, D. (2019) *Windows 10: the best Windows OS review | TechRadar*. Available at: <https://www.techradar.com/reviews/pc-mac/software/operating-systems/windows-10-1267364/review> (Accessed: 13 October 2019).
- [17] Hong, J. and Hong, J. (2012) 'The Current State of Phishing Attacks The Current State of Phishing Attacks', *Communications of the ACM*, 55(1), pp. 74–81. doi: 10.1145/2063176.2063197.
- [18] Jorgensen, Z., Zhou, Y. and Inge, M. (2008) *A Multiple Instance Learning Strategy for Combating Good Word Attacks on Spam Filters*, *Journal of Machine Learning Research*. Available at: <http://www.jmlr.org/papers/volume9/jorgensen08a/jorgensen08a.pdf> (Accessed: 11 December 2018).
- [19] Litan, A. (2004) *Phishing Attack Victims Likely Targets for Identity Theft*. Available at: [https://www.social-engineer.org/wiki/archives/IdTheif/IdTheif-phishing\\_attack.pdf](https://www.social-engineer.org/wiki/archives/IdTheif/IdTheif-phishing_attack.pdf) (Accessed: 11 December 2018).
- [20] Lowd, D. and Meek, C. (no date) *Good Word Attacks on Statistical Spam Filters*. Available at: [http://www.utdallas.edu/~muratk/courses/dmsec\\_files/125.pdf](http://www.utdallas.edu/~muratk/courses/dmsec_files/125.pdf) (Accessed: 27 November 2018).
- [21] Medium. (2018). Classify emails into ham and spam using Naive Bayes Classifier. [online] Available at: <https://medium.com/swlh/classify-emails-into-ham-and-spam-using-naive-bayes-classifier>.
- [22] Pippi, G., 2020. *Advanced VBA Macros: Bypassing Olevba Static Analyses With 0 Hits*. [online] Certego. Available at: <https://www.certego.net/en/news/advanced-vba-macros/> [Accessed 14 September 2020].
- [23] Robert, R. and Kolcz, A., 2020. *Improving Spam Filtering By Detecting Gray Mail*. [online] Scottyih.org. Available at: [http://scottyih.org/files/Improve\\_Spam\\_Filtering\\_by](http://scottyih.org/files/Improve_Spam_Filtering_by)

- [\\_Detecting\\_Gray\\_Mail.pdf](#)> [Accessed 14 September 2020].
- [24] Ramzan, Z. (2010) ‘Phishing Attacks and Countermeasures’, in *Handbook of Information and Communication Security*. Berlin, Heidelberg: Springer Berlin Heidelberg, pp. 433–448. doi: 10.1007/978-3-642-04117-4\_23.
- [25] Rongala, A. (2015) *Benefits of Java over Other Programming Languages - Invensis Technologies*. Available at: <https://www.invensis.net/blog/it/benefits-of-java-over-other-programming-languages/> (Accessed: 13 October 2019).
- [26] Sahami, M. *et al.* (no date) *A Bayesian Approach to Filtering Junk E-Mail*. Available at: <http://robotics.stanford.edu/users/sahami/papers-dir/spam.pdf> (Accessed: 11 December 2018).
- [27] San Martino, A. and Perramon, X. (2011) *Phishing Secrets: History, Effects, and Countermeasures*, *International Journal of Network Security*. Available at: <https://pdfs.semanticscholar.org/ce2c/79720dc4eaca6d1263323b04d09262fe392c.pdf> (Accessed)
- [28] Schreck, T., Berger, S. and Göbel, J. (2013) ‘BISSAM: Automatic Vulnerability Identification of Office Documents’, in Springer, Berlin, Heidelberg, pp. 204–213. doi: 10.1007/978-3-642-37300-8\_12.
- [29] Spirin, N. and Han, J. (2012) ‘Survey on web spam detection’, *ACM SIGKDD Explorations Newsletter*. ACM, 13(2), p. 50. doi: 10.1145/2207243.2207252.
- [30] Susan Rose, N. S. and A. I. (2015) *An introduction to using Microsoft Excel for quantitative data analysis*. Available at: <http://office.microsoft.com/en-001/support/?CTT=97> (Accessed: 8 January 2019).
- [31] Ucci, D., Aniello, L. and Baldoni, R., 2019. Survey of machine learning techniques for malware analysis. *Computers & Security*, 81, pp.123-147.
- [32] Wielenga, G. (2014) *Top 5 Benefits of NetBeans Platform for Beginners* | Oracle Geertjan’s Blog. Available at: <https://blogs.oracle.com/geertjan/top-5-benefits-of-netbeans-platform-for-beginners> (Accessed: 13 October 2019).
- [33] Wombat Security, a. (2018). 2018 State of the Phish. [online] Wombatsecurity.com. Available at: <https://www.wombatsecurity.com/state-of-the-phish> [Accessed 3 Dec. 2018].
- [34] Youn, S. and McLeod, D. (2007) ‘A Comparative Study for Email Classification’, in *Advances and Innovations in Systems, Computing Sciences and Software Engineering*. Dordrecht: Springer Netherlands, pp. 387–391. doi: 10.1007/978-1-4020-6264-3\_67
- [35] Zareapoor, M. and K. R, S., 2015. Feature Extraction or Feature Selection for Text Classification: A Case Study on Phishing Email Detection. *International Journal of Information Engineering and Electronic Business*, 7(2), pp.60-65.

# Exploring The Antecedents, Drivers, And Outcome Of Behaviour-Based Safety: A Literature Review

<sup>[1]</sup> Sujata Sinha, <sup>[2]</sup> Dr. Ashutosh Muduli

<sup>[1][2]</sup> School of Petroleum Management, Pandit Deendayal Petroleum University, Gujarat, India  
Email: <sup>[1]</sup> sujata.sphd19@spm.pdpu.ac.in, <sup>[2]</sup> ashutosh.muduli@spm.pdpu.ac.in

**Abstract**— Organisations good at managing safety tend to manage operations well. Safety culture is a subset of organisational culture and is the observable degree of effort with which all the organisation members exert their attention and action towards safety. People neither deterministically controlled by their environments nor entirely self-determining. They are in a state of reciprocal determinism with their settings, where they and their environments influence one another. Safety leadership can positively impact an individual's safety-related behaviour by up to 86% and reduce accidents by around 35%. Evidence directs us towards safety culture and safety leadership as prominent precursors to workers' safety behaviour (WSB). This study conducts a rigorous review of approximately 20-25 published papers from 2000 to 2019, related articles in books and articles published in the corresponding field journals. The research evidence shows that Cooper's reciprocal model of safety culture encompassing psychological, behavioural and situational factors is well supported by most studies. They offer non-existent to a weak relationship between psychological factors and strong and steady situational and behavioural factors with the safety outcomes. Organisations should concentrate 80% of their safety culture improvement efforts on situational and behavioural factors to prevent process safety and SIF (Significant incidents and fatalities). Behavioural-based safety (BBS) process serves as a comprehensive tool in altering at-risk behaviour positively. BBS will help the practitioners design enhanced BBS intervention for a more sustainable and persistent impact on workers' safety behaviour (WSB). Further research should be undertaken to establish the empirical links of safety culture and safety leadership constructs with safe outcomes.

**Index Terms**— Safety culture, safety leadership, safety performance, Behaviour-based safety

## I. INTRODUCTION

Organisations are good at managing safety happen to manage their operations well. Safety and overall operational excellence go hand in hand. Corporate safety culture is supposed to have a strong influence on overall workplace injuries and fatalities. After implementing occupational health and safety in the organisation, there has been significant improvement in workplace safety. However, many cases of the accident are being reported even after best of organisations management, training, strict safety rules & regulations and best of equipment in place. The complexity of industrial systems poses a challenge for industrial safety as it can be a source of deviations from normal behaviour. Traditional methods of incident investigation focus primarily on the technical aspect. But the conventional model of risk analysis is not found suitable for complex industrial setup as they call for a necessity to take into account the interactions between human, technical and organisational components.

Evidence directs us towards safety culture and safety leadership as prominent precursors to workers' safety behaviour (WSB).

## II. METHODOLOGY

This paper follows a systematic literature review methodology to identify, analyse and draw inference from the available literature to identify the most important antecedents of workplace safety. The study conducts a rigorous review of approximately 20-25 published papers from 2000 to 2019, related articles in books and articles

published in the corresponding field journals. Evidence directs us towards safety culture and safety leadership as prominent precursors to workers' safety behaviour (WSB).

## III. RESULT

### (i) Safety Culture

During the 1980s, there was no empirical evidence discovered in the construct. Many process safety catastrophes resulting in hundreds and thousands of industrial workers are killed or injured every week directed to an unknown, unidentified underlying contributor if identified, could have helped improve the situation. The chain of such events across different industries the safety construct was born and explained the unknown. The term 'safety culture' first made its appearance in 1987 after the 1986 Chernobyl disaster in the OECD Nuclear agency report (INSAG, 1988) on the 1986 Chernobyl disaster.

The study reveals that safety culture at different levels of the organisation influence different types of unsafe behaviours, which the risk of work injuries in turn. Thus, it is desirable to study safety culture at different/various analytical levels (i.e., the national, sectorial and organisational) to understand the effect of culture on safety thoroughly. Safety culture is defined as the share of an organisation's culture related to safety [12]. It is the observable degree of efforts with which all the organisation members direct their efforts and actions towards improving safety. Safety culture also refers to a corporate atmosphere which influences people's management of safety in an organisation—the number of culture definition advocate

that one definition does not fit all industries. The crust of safety culture construct is about thinking positively about safety, proactively managing safety, and behaving safely.

The results show that when the safety culture was strong, leaders' behaviour created a higher/improved safety climate among the members, which predicted the workers' perceived safety behaviours. Safety culture moderated the influence that leaders exercise on safety climate. Cooper's (2000) Reciprocal safety culture Model (Fig. 1) encompassing psychological factor (safety climate), behavioural (safety behaviour) and situational factors (safety management system) has been supported by most of the academicians and researchers working on accident prevention and safety enhancement [7].



Fig 1: Cooper (2000): Reciprocal Safety Culture Model

People are neither deterministically controlled by their environments nor completely self-determining [12]. They are in a state of reciprocal determinism. They and their environments influence each other. 'Bandura's model of reciprocal determinism' offers a perfect framework to measure and analyse 'safety culture' by a triangular methodology to perform multi-level analyses. This triangulation lets the researcher take a multi-faceted understanding of safety culture. Organisations can study the reciprocal relationship between situational, psychological, and behavioural factors with an opinion to establish antecedents-behaviour-consequence path. As the elements are measurable, it is possible to quantify the 'safety culture' in a more meaningful way at many different organisational and analytical levels. The reciprocal framework provides a suitable means by which the prevailing safety culture of other business units, departments or work areas can be measured and compared [12]. Previous research findings suggest that change initiatives that disregard this interactive relationship while developing a safety culture are bound to failure.

Cooper's (2002) business model of safety culture (Fig.2) treats the psychological ('hearts & minds'), behavioural ('daily actions') and situational ('Safety guidelines/systems') aspects as the input to the safety culture construct which undergo a transformational process via leadership through organisational goals, expectations and management practices to produce/form the safety culture. This approach has been officially accepted by the American Petroleum Association (2016) and has also been considered standard by the American National Standards Institute (ANSI).

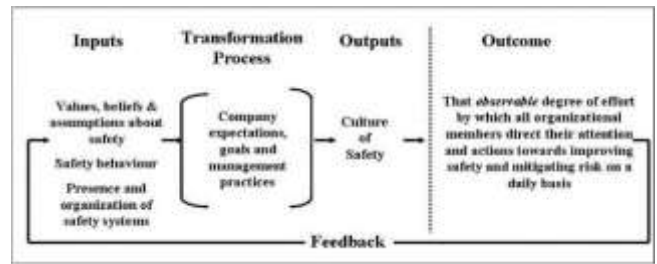

Fig 2: Cooper (2002): Business Process Model of Safety Culture

Defining 'safety culture' construct as a product helps us with a means to measure the degree of existing safety culture in the organisation. The collective evidence depicts minimal to no relationship of psychological aspects with safety outcome. It also means that the use of psychological factors as a substitute for safety culture is almost incorrect.

Change and modifying situational aspects by introducing an efficient safety management system (SMS) that codifies and directs individuals' behaviour significantly optimises the safety conditions responsible for process safety accidents and personal injuries. Finally, there is a large body of work, primarily aimed at improving workers safety behaviour (WSB) in a range of industries and countries known as "Behavioural-Based Safety" (BBS). This is an approach aimed at improving workplace safety by modifying unsafe behaviour to safe behaviour.

(ii) Leadership

Leadership is defined as the capacity to influence people through personal attributes and behaviour to achieve a common goal and an essential element in guaranteeing organisations' safe running. Effective leaders understand that health and safety are not just a moral responsibility, but also contribute to achieve the organisational objectives across finance, operations, compliance and governance.

A manager's leadership style and visual demonstration of their commitment to overall health & safety through their actions play a crucial role in shaping safety culture. The present study aims to find out how leader behaviours influence employees' safety behaviours (perceived safety behaviours). To answer this question, we have considered how this influence is exercised, taking into consideration some essential factors like safety performance, safety compliance & safety participation. The analyses revealed that transformational leadership is characterised leaders behaviour that transforms and inspire followers to go above and beyond their mere self-interest, promote supervisory safety practices, create a positive, supportive environment, better safety behaviours and fewer accidents. At the same time, transactional leaders are just concerned with safety performance through constructive and corrective measures. In other words, transactional safety leaders promote safety performance (i.e. use of PPE & safety compliance) and transformational safety leaders encourage "safety participation". Several studies revealed the co-occurrence of transformational and transactional safety leadership and



claim that while safety leaders need transactional skills but in the absence of transformational skills it is impossible to generate employee's engagement towards health & safety. From the past few years "safety participation" has become the focus of much recent behavioural safety research. Initially, various acts of employees' safety participation were presented as a single construct, implying that all actions were of equal importance in predicting organisational safety outcome. Recent studies propose safety participation behaviour in two distinct categories: prosocial and proactive safety participation behaviour and the type of effect they exert on different safety performance outcomes such as micro-accidents, property damage, lost time injury and near-miss reporting event. In recent studies, Prosocial behaviour was found to be useful in predicting the frequency of micro-accidents and accidents without injury (property damage). In contrast, proactive behaviour played a vital role in predicting the frequency of lost time injury and near-miss events (Curcuruto et al.,2015).

#### IV. DISCUSSION

##### Behaviour-Based Safety and its role in changing Behaviour

Research has shown that up to 80% of workplace accidents are caused by workers behaviour, so it is imperative to understand why employee behave unsafely. Pareto's law dictates that 80% of the consequences stem from 20% of the causes. Application of this principle on accidents demonstrates that 20% of behaviours are responsible for 80% of accidents. Therefore, logically it is advisable to restrict the focus on critical and current behaviour to achieve the desired result rather than overloading the workers to all safety acts to be performed onsite. This limits the dilution of focus and achieves the desired result. Peoples behavioural choices account for around 56% of all potential severe injuries and fatalities (SIF's). Workers may participate in risk-taking behaviour that might have life-altering consequences. Under everyday situations, they may have the ability and knowledge to perform the tasks, but she/he may not have the required motivation to carry it out [14]. A favourable work environment positively influences the operators' behaviour, and an unfavourable work environment negatively impacts the operator's behaviour. The purpose of BBS is to reduce the number of unwanted incidents caused either poor management controls and/or hazard present in the working environment: when they are triggered exclusively by 'unwanted behaviour' or those triggered by an interaction between poor controls, hazards and behaviours. Preventative opportunities, therefore, stem from controlling unwanted behaviours, identifying/eliminating risks and tightening management controls. Behavioural safety helps to identify and fix issues in all of these areas. It is vital not to confuse this approach with inspections, looking at unsafe conditions instead of unsafe acts. However, behavioural techniques aimed at improving safety-

related behaviour reduce injuries if applied while meeting the pre-requisites before implementation. Various research evidence suggests that behavioural interventions aimed at improving an organisation's safety performance would be more effective if they target specific safety behaviour (prosocial or proactive) associated with these outcomes. Otherwise, they will have minimal to no effect.

#### V. CONCLUSION

Most of the studies explained the role of safety culture in shaping the behaviour of the employees and the role of leaders plays in transformation of safety culture leading to safer outcomes.

- The available evidence illustrates safety climate (psychological factor) as an inconsistent and weak indicator of safety-related behaviour and sole use of psychological factor (safety climate /attitudinal survey) as a substitute to safety culture is inappropriate.
- Behavioural and situational factors demonstrate a strong and reliable relationship with actual safety behaviour/outcomes. Organisations should focus almost 80% of their safety culture improvement initiatives in modifying the situational factor by developing a robust safety system to influence and optimise safety-related behaviour to avoid process safety and SIF's. In turn, to decrease any cognitive disagreement (Festinger, 1957), people will by default adjust their way of thinking to decrease any discomfort between the way they think and the way they act .
- Most of safety issues/concerns reveal that it is the management behaviours from where 80% of personal injury or process safety issues arise.
- Organisations must concentrate on the behaviour of workers and management but should recognise that behavioural targets for each will be significantly different.
- Behavioural-based safety interventions have proved to be successful across various industries through their exclusive bottom-up approach to manage health and safety at the workplace. There lies a scope of research into its effectiveness.
- Behavioural-based techniques work best when physical environment and workplace are well maintained, and all procedures are in place. The implementation of BBS provides an opportunity to the workforce to proactively and continuously co-operate to improve safety and health.
- Supervisors safety practices (i.e., Frequent safety-specific interaction with workers) can lead to improvement in workers safety behaviour (WSB) and an improved safety climate.

A more detailed study to explore empirical links of safety culture and safety leadership constructs with safe outcomes needs be carried out.

## REFERENCES

- [1] A. Parand and P. Foster, "Behavioural-Based Safety in the Minerals Industry: A Research Based Methodology Carried out in the UK Quarrying Sector", In Queensland Resources Council Mining Health & Safety Conference 2006.
- [2] C. Pilbeam, R. Davidson, N. Doherty and D. Denyer, "Safety leaders: who are they? What do they do", 2016.
- [3] D. Cooper, "Safety culture", *Professional safety*, 47(6), 30-36, 2002.
- [4] D. Zohar & G. Luria, "The use of supervisory practices as leverage to improve safety behavior: A cross-level intervention model", *Journal of safety research*, 34(5), 567-577, 2003
- [5] D. Zohar, "Modifying supervisory practices to improve subunit safety: a leadership-based intervention model" *Journal of Applied psychology*, 87(1), 156, 2002.
- [6] D.C.C.C. Psychol, "Navigating the Safety Culture Construct: A Review of the Evidence", 2016.
- [7] J. Lund and L.E. Aarø, "Accident prevention. Presentation of a model placing emphasis on human, structural and cultural factors", *Safety science*, 42(4), 271-324, 2004.
- [8] J. Mullen, E.K. Kelloway and M. Teed, "Inconsistent style of leadership as a predictor of safety behaviour", *Work & Stress*, 25(1), 41-54, 2011.
- [9] M. Curcuruto, S.M. Conchie, M.G. Mariani, and F.S. Violante, "The role of prosocial and proactive safety behaviors in predicting safety performance", *Safety science*, 80, 317- 323, 2015.
- [10] M. Martínez-Córcoles, F. Gracia, I. Tomas and J.M. Peiró, "Leadership and employees' perceived safety behaviours in a nuclear power plant: A structural equation model" *Safety science*, 49(8-9), 1118-1129, 2011.
- [11] M. S. Abdullah, Y.H. Othman, A. Osman, & S. N. Salahudin, "Safety culture behaviour in electronics manufacturing sector (EMS) in Malaysia: The case of flextronics", *Procedia economics and finance*, 35, 454-461, 2016
- [12] M.D. Cooper, "Towards a model of safety culture", *Safety science*, 36(2), 111- 136, 2000.
- [13] N. Gravina, B. Cummins and J. Austin, "Leadership's role in process safety: An understanding of Behavioral science among managers and executives is needed", *Journal of Organizational Behavior Management*, 37(3-4), 316-331, 2017.
- [14] R. Aulin, A. Ek and C. Edling, "Underlying Causes for Risk Taking Behaviour Among Construction Workers" In 10th Nordic Conference on Construction Economics and Organization (Emerald Reach Proceedings Series, Volume 2). Emerald Publishing Limited (pp. 419-426), 2019.
- [15] S. Zhang, X. Shi and C. Wu, "Measuring the effects of external factor on leadership safety behavior: Case study of mine enterprises in China", *Safety science*, 93, 241-255, 2017

# Research-Based Learning Applied In First Semester Courses Of Engineering Programs (Preliminary Study)

<sup>[1]</sup> C. J. Diliegros-Godines, <sup>[2]</sup> Adriana Erika Martínez-Canton, <sup>[3]</sup> Victoria Ubici

<sup>[1]</sup> Tecnológico de Monterrey, Av. Atlixcayotl, Reserva Territorial Atlixcáyotl, Puebla, Pue

<sup>[2]</sup> Tecnológico de Monterrey, Av. Eugenio Garza Sada Sur, Tecnológico, Monterrey, N.L

Email: <sup>[1]</sup>jdiliegros@tec.mx

**Abstract**— The development of research abilities is a necessary competency for students of Engineering and Science. Regardless of the engineering field of interest, the development of global competencies influences their professional performance. In the present work, we describe the impact, from the students' perception, of the early approach in research activities that involves critical thinking, innovation, problem-solving, self-direction, leading, and written communication abilities. To introduce the students to Research-Based Learning (RBL), we asked them to develop a solution to a problem presented in a first-semester science class in a university focused on developing technical and transversal competencies. This work proposes a teaching methodology based on RBL, which includes the appropriate use of search tools, data analysis, and writing skills, taking advantage of the institution's resources. Simultaneously, we looked for an effective research methodology to build a solid theoretical framework relevant to their experimental results. Moreover, we aimed to link the theoretical course contents to the student's engineering field through RBL activities. The sample under study had 98 students taking an experimental physics and statistical analysis course; 49 in an experimental group (class) were guided using RBL, and the other students were in the control group. The evaluation of the learning outcomes was carried out comparing the pre-and-post surveys, using a 5-point Likert scale (ranging from strongly disagree to strongly agree). The statistical analysis of the experimental guided group results showed an increase in critical thinking, innovation, problem-solving, and self-direction compared to the control group students. However, the leadership competency did not show any improvement in both groups. We concluded that implementing the RBL methodology for students in the early stages of engineering education promoted and reinforced the development of technical and transversal competencies.

**Index Terms**— Educational Innovation, Research-based Learning, Learning Activities, Higher Education Transversal Competencies

## I. INTRODUCTION

Research-based learning (RBL) has become a primary educational methodology to develop professional competencies in higher education. Studies have reported several advantages of using RBL in all areas of undergraduate education, such as engineering [1,2], medicine [3], physiology [4], and teacher education [5], among others. In particular, Singh et al. [6] have shown that the use of RBL by engineering undergraduates develops and enhances problem-solving, domain knowledge, language and communication, information and communication technology (ICTs), general learning, academic knowledge, attitude, and ethical skills. Through RBL strategy, Mayolo-Deloisa et al. [7] demonstrated that students taking theoretical and laboratory courses in Enzymology and Biocatalysis could generate experimental data and develop competencies to acquire knowledge, attain outstanding commitment, and improve research skills. The RBL technique is usually implemented during the last year of undergraduate study or postgraduate [8]; however, an earlier introduction to RBL can significantly impact the development of skills for the students' chosen occupational fields.

The teaching and learning processes necessary to implement RBL still challenges professors. There are four principal barriers: 1) teacher mindset, 2) teaching methodology, 3) curricular design, and 4) academic leadership [9]. It has been observed that, depending on the professor's experience and the course focus, the inclusion of RBL in higher education leads to several strategies. Consequently, the student experience of RBL can be broad and shallow and may not be sufficient for them to achieve the academic or competency level desired [5].

In this work, we propose a simple teaching methodology based on research activities applied in a second-semester higher education course called "Experimental Physics and Statistical Thinking" in the School of Engineering and Sciences (SES) at Tecnológico de Monterrey. Here, the evaluation of the students' perception of developing their skills and competencies was carried out comparing pre-and-post-surveys, using a 5-point Likert scale [10] (strongly disagree to strongly agree). The results showed that the students perceived that the activities helped them increase their technical and transversal competencies.

## II. METHODOLOGY

This work is based on the early-stage immersion of students into a well-structured RBL methodology. The sample under study was composed of 98 students of an experimental physics and statistical analysis course, where only 49 students were guided using the RBL, and the rest were part of the control group. It is important to mention that the course was carried out in a five-week period in the middle of the semester, and the students came from all the engineering specialties.

The first step was to introduce the students to the digital library and database available in the university. The students received a 1-hour workshop about digital resources and how to use them.

### 2.1. Evaluation of student's perception of technical and transversal competencies

In order to perform statistical analysis, the authors applied two online surveys asking students to rate statements about their learning on a Likert scale [10] with five options: 1) Strongly disagree, 2) Disagree, 3) Somewhat agree, 4) Agree, 5) Strongly agree. All the statements were phrased in such a manner that the higher scores indicated a positive result.

#### 2.1.1 Pre-survey

The pre-survey was applied at the beginning of the course and included the following questions:

Q1. Rate your skill level in the following transversal competencies:

- Critical thinking (CT)
- Innovation (In)
- Leadership (Le)
- Problem-solving (PS)
- Self-direction (SD)

Q2. Rate your skill level in the following technical competencies:

- Scientific Methodology in engineering problems (SM)
- Correct use of mathematical tools (MT)
- Observation ability (OA)
- Use of graphs to perform statistical analysis (SA)
- Understanding of nanotechnology concepts (NT)
- Ability to identify relevant information to conduct research (RI)

Q3. What are the sources of information that you usually use?

Q4. Rate the frequency of use of the following digital resources: Google, Google Scholar, ScienceDirect, and the Digital Library from this institution.

#### 2.1.2 Post-survey

The post-survey (exit survey) was applied at the end of the course. It asked the students to reflect on how their technical and transversal competencies improved due to taking the course. This was evaluated using similar questions to Q1 and Q2 in the pre-survey.

Also, the following questions were included:

Q3. How much did your interest in research increase after the course?

Q4. How much did your ability to search and choose information relevant to your activity increase?

The scale reliability of the pre-and-post tests was measured for internal consistency through Cronbach's alpha. Values of this statistic above 0.70 were considered to represent adequate reliability and right internal consistency [4,11]. The values of the tests' samples showed good reliability with alfa between 0.74 and 0.83.

### 2.2. Activities proposed

As mentioned, this work proposed a simple methodology to implement RBL in higher education. The activities proposed are shown in Table 1. It is essential to mention that all the activities must be guided by the professor and include continuous feedback to the students.

### 2.3. Statistical analysis

The students' answers about their perception of the development of competencies were analyzed by comparing the final answer in their level of skill perception with the initial answer using Excel and Minitab. A percentage difference in both answers was calculated:  $\Delta\% = \frac{\text{post-survey answer} - \text{pre-survey answer}}{\text{pre-survey answer}} \times 100$ . Negative values obtained in the lower Likert scale (1 and 2) and positive values on the high end of the scale (4 and 5) meant that the student's perception was they improved their competency. On the other hand, a positive value on the lower end (1 and 2) and a negative value on the high end (4 and 5) indicated student confusion about their competency.

Also, to prove the efficiency of research-based learning, the pre-and-post survey results were compared and analyzed using the Shapiro Wilk normality test. All the tests showed  $p > 0.05$ , implying that the samples were normally distributed [12]. Then, paired-sample t-tests were conducted comparing the students' perceived learning outcomes to identify significant statistical differences [13,14].



Table 1. Description of activities using RBL methodology

Learning Activity	Objective	Time of the course
Key questions about the activity guided bibliographical research about the problem to solve.	To help the student recognize trustworthy digital resources available in their institution to perform scientific research.	First week.
A written report about two group experimental activities. The reports should follow the standard structure of a scientific paper. The students receive guidance on how to write a scientific paper.	To evaluate student competencies and abilities related to RBL. To provide feedback to the students after each delivered report to improve their competencies for the next reports.	Second and third weeks.
Advanced bibliographical research about the problem to solve. This research focused on published papers and patents.	To narrow the information search to relevant published works. To provide final feedback to the students.	Fourth week.
Written and oral presentations about the solution proposed for the established problem.	To evaluate the competencies of the students.	Fifth week.

III. RESULTS

The pre-survey questions Q3 and Q4 showed that the most used digital resource was Google (Likert rating 5), followed by Google Scholar (rating 4), Digital Library (rating 4), and ScienceDirect (rating 1).

The Δ% results for the pre-and-post surveys are shown in Figure 1 for transversal competencies and Figure 2 for technical competencies. In general, there is an increase in the transversal and specific competencies for all the students. However, we can observe differences between the RBL and control groups.

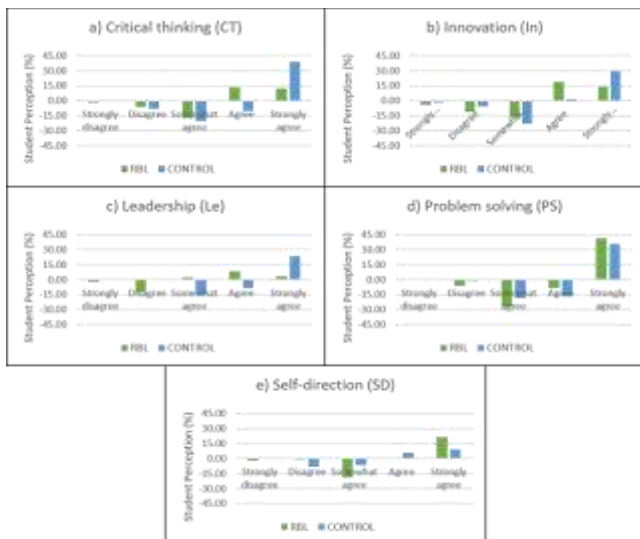

Figure 1. Student perception of skill levels in transversal competencies.

The control group had more freedom to perform their activities; this was reflected in an increase in their perception of the CT, In, and Le competencies (Figure 1, a to c). On the other hand, the RBL group showed a remarkable improvement in PS and SD competencies (Figure 1, d to e).

In Figure 2 for technical competencies, we can observe that the RBL group perception of SM and MT competencies was deficient at the beginning of the course. However, after using the RBL methodology, the students reported a significant improvement in their skill levels, moving from Likert scale 1-2 to 5 on the scale. On the other hand, the control group showed an increment of only one level on the scale from pre-survey to post-survey in the SM and MT competencies. In the OA and SA competencies (Figure 2, c and d), both groups had dispersed perception in the pre-survey and improvement to levels 4 and 5 after the course, which was intended by the course design and objectives.

The competencies strongly associated with research, such as NT and RI, are the ones that showed the most significant improvement due to the RBL methodology. In Figure 2 e and f, it can be observed that the RBL group perceived an increase in those skill competencies, rating them 4 to 5 on the Likert scale after the course, while the control group had a dispersed perception of their skills.

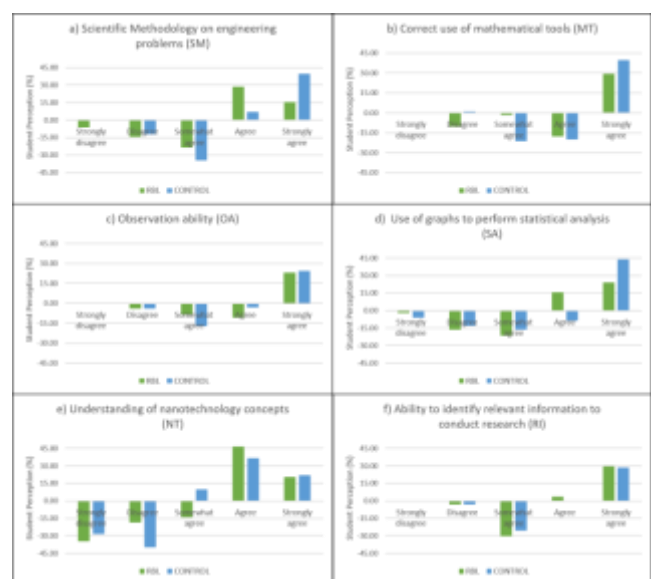

Figure 2. Student perception of skill levels in technical competencies.

The highest impact of the RBL methodology was measured in the Q4 post-survey question. Figure 3 shows that more than 50% of the RBL group students believed their research skills for relevant information had highly improved. In contrast, the control group's opinion about that technical skill was dispersed.

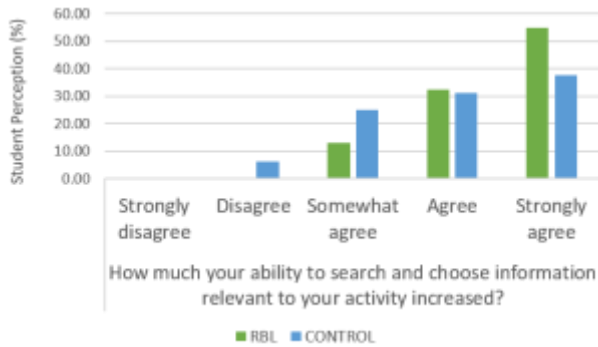

Figure 3. Students' perception of their search skills and choosing relevant information.

To support the observations made by the  $\Delta\%$  study, we performed paired-sample t-tests for transversal and technical competencies on the whole sample of students (i.e., 98 students). The results are shown in Tables 2 and 3.

According to the p-values calculated with Minitab, a significance level ( $\alpha$ ) of 0.05 indicates that for the CT, In, PS, and SD competencies, the null hypothesis was rejected, meaning that the differences between the initial value and the final values of each competency are less than zero. In other words, a significant difference between the initial value and the final value of the competencies was observed, implying that the RBL helps improve those skills in the students.

For the Leadership competency, the null hypothesis was accepted, concluding that there is insufficient information to say that the RBL improves this skill.

Table 2. Paired T-test for transversal competencies.

<p><b>Hypothesis Test</b>                  Null hypothesis: <math>H_0</math>: the difference between the initial value and the final value of the competencies (<math>\mu</math>) = 0                  Alternative hypothesis: <math>H_1</math>: the difference between the initial value and the final value of the competencies (<math>\mu</math>) &lt; 0</p>	<p><b>Paired T-Test for critical thinking (CT)</b>  <math>\mu_{\text{difference}}</math>: population mean of (CT Initial - CT Final)  <b>Test</b>                  Null <math>H_0</math>: <math>\mu_{\text{difference}}</math>                  Alternative <math>H_1</math>: <math>\mu_{\text{difference}}</math>  <u><b>T-Value</b>    <b>P-Value</b></u>                  -5.41            0.0000005</p>
---	---

<p><b>Paired T-Test for Innovation (In)</b>  <math>\mu_{\text{difference}}</math>: population mean of (In Initial - In Final)  <b>Test</b>                  Null <math>H_0</math>: <math>\mu_{\text{difference}}</math>                  Alternative <math>H_1</math>: <math>\mu_{\text{difference}}</math>  <u><b>T-Value</b>    <b>P-Value</b></u>                  -3.52            0.0004</p>	<p><b>Paired T-Test for Leadership (Le)</b>  <math>\mu_{\text{difference}}</math>: population mean of (Le Initial - Le Final)  <b>Test</b>                  Null <math>H_0</math>: <math>\mu_{\text{difference}}</math>                  Alternative <math>H_1</math>: <math>\mu_{\text{difference}}</math>  <u><b>T-Value</b>    <b>P-Value</b></u>                  -1.65            0.052</p>
<p><b>Paired T-Test for Problem Solving (PS)</b>  <math>\mu_{\text{difference}}</math>: population mean of (PS Initial - PS Final)  <b>Test</b>                  Null <math>H_0</math>: <math>\mu_{\text{difference}}</math>                  Alternative <math>H_1</math>: <math>\mu_{\text{difference}}</math>  <u><b>T-Value</b>    <b>P-Value</b></u>                  -4.95            0.000003</p>	<p><b>Paired T-Test for Self-Direction (SD)</b>  <math>\mu_{\text{difference}}</math>: population mean of (SD Initial - SD Final)  <b>Test</b>                  Null <math>H_0</math>: <math>\mu_{\text{difference}}</math>                  Alternative <math>H_1</math>: <math>\mu_{\text{difference}}</math>  <u><b>T-Value</b>    <b>P-Value</b></u>                  -3.62            0.0003</p>

Regarding the results obtained in Minitab for the technical competencies, there is a significant difference between the pre-and-post survey values, meaning that the RBL improves the SM, MT, OA, SA, NT, and RI competencies (See Table 2).

Table 2. Paired T-test for specific competencies

<p><b>Paired T-Test for Scientific methodology on engineering problems (SM)</b>  <math>\mu_{\text{difference}}</math>: population mean of (SM Initial - SM Final)  <b>Test</b>                  Null <math>H_0</math>: <math>\mu_{\text{difference}}</math>                  Alternative <math>H_1</math>: <math>\mu_{\text{difference}}</math>  <u><b>T-Value</b>    <b>P-Value</b></u>                  -7.26            0.000000</p>	<p><b>Paired T-Test for Correct use of mathematical tools (MT)</b>  <math>\mu_{\text{difference}}</math>: population mean of (MT Initial - MT Final)  <b>Test</b>                  Null <math>H_0</math>: <math>\mu_{\text{difference}}</math>                  Alternative <math>H_1</math>: <math>\mu_{\text{difference}}</math>  <u><b>T-Value</b>    <b>P-Value</b></u>                  -4.08            0.00006</p>
<p><b>Paired T-Test for Observation ability (OA)</b>  <math>\mu_{\text{difference}}</math>: population mean of (OA Initial - OA Final)  <b>Test</b>                  Null <math>H_0</math>: <math>\mu_{\text{difference}}</math>                  Alternative <math>H_1</math>: <math>\mu_{\text{difference}}</math>  <u><b>T-Value</b>    <b>P-Value</b></u>                  -3.15            0.00124</p>	<p><b>Paired T-Test for the Use of Graphs to perform statistical analysis (SA)</b>  <math>\mu_{\text{difference}}</math>: population mean of (SA Initial - SA Final)  <b>Test</b>                  Null <math>H_0</math>: <math>\mu_{\text{difference}}</math>                  Alternative <math>H_1</math>: <math>\mu_{\text{difference}}</math>  <u><b>T-Value</b>    <b>P-Value</b></u>                  -6.78            0.00000</p>

<p><b>Paired T-Test for Understanding nanotechnology concepts (NT)</b></p> <p><math>\mu_{\text{difference}}</math>: population mean of (NT Initial – NT Final)</p> <p><b>Test</b></p> <p>Null            <math>H_0: \mu_{\text{difference}}</math> Alternative <math>H_1: \mu_{\text{difference}}</math></p> <p><b>T-Value</b>    <b>P-Value</b></p> <p style="text-align: center;">-10.05        0.00000</p>	<p><b>Paired T-Test for Ability to identify relevant information to conduct research (RI)</b></p> <p><math>\mu_{\text{difference}}</math>: population mean of (RI Initial – RI Final)</p> <p><b>Test</b></p> <p>Null            <math>H_0: \mu_{\text{difference}}</math> Alternative <math>H_1: \mu_{\text{difference}}</math></p> <p><b>T-Value</b>    <b>P-Value</b></p> <p style="text-align: center;">-5.63        0.00000</p>
---	---

**REFERENCES**

- [1] A. Suwito, Purwanto, N.I. Parta, S. Irawati, J.W. Dika, Reducing the main problem of proposals in undergraduate research through research-based learning activity students, TEM J. 8 (2019) 1213–1217. doi:10.18421/TEM84-15.
- [2] E. Ruiz-Ramos, J.M. Romero-García, F. Espínola, I. Romero, V. Hernández, E. Castro, Learning and researching based on local experience and simulation software for graduate and undergraduate courses in chemical and environmental engineering, Educ. Chem. Eng. 21 (2017) 50–61. doi:10.1016/j.ece.2017.05.001.
- [3] C. Sota, K. Peltzer, The Effectiveness of Research Based Learning among Master degree Student for Health Promotion and Preventable Disease, Faculty of Public Health, Khon Kaen University, Thailand, Procedia - Soc. Behav. Sci. 237 (2017) 1359–1365. doi:10.1016/j.sbspro.2017.02.226.
- [4] F.A. Santirso, M. Martín-Fernández, M. Marco, V. Vargas, M. Lila, E. Gracia, La investigación visita el aula: la promoción del conocimiento y la práctica de la investigación como estrategia docente innovadora, (2017). doi:10.4995/inred2017.2017.6801.
- [5] A. Brew, C. Saunders, Making sense of research-based learning in teacher education, Teach. Teach. Educ. 87 (2020) 102935. doi:10.1016/j.tate.2019.102935.
- [6] R. Singh, Devika, C. Herrmann, S. Thiede, K.S. Sangwan, Research-based Learning for Skills Development of Engineering Graduates: An empirical study, Procedia Manuf. 31 (2019) 323–329. doi:10.1016/j.promfg.2019.03.051.
- [7] K. Mayolo-Deloisa, A.M. Ramos-de-la-Peña, O. Aguilar, Research-based learning as a strategy for the integration of theory and practice and the development of disciplinary competencies in engineering, Int. J. Interact. Des. Manuf. 13 (2019) 1331–1340. doi:10.1007/s12008-019-00585-4.
- [8] Suntusia, Dafik, Hobri, The effectiveness of Research Based Learning in improving students' achievement in solving two-dimensional arithmetic sequence problems, Int. J. Instr. 12 (2019) 17–32. doi:10.29333/iji.2019.1212a.
- [9] W. Rattanaprom, Failure of Research-Based Learning Implementation in Basic Education, Int. Educ. Stud. 12 (2019) 19. doi:10.5539/ies.v12n4p19.
- [10] R. Likert, A technique for the measurement of attitudes, Arch. Psychol. 22 (1932) 55.
- [11] S.F.E. Rovers, G. Clarebout, H.H.C.M. Savelberg, J.J.G. van Merriënboer, Improving student expectations of learning in a problem-based environment, Comput. Human Behav. 87 (2018) 416–423. doi:10.1016/j.chb.2018.02.016.

These results are similar to those observed in Figures 1 and 2. However, a more in-depth study must be made to clearly identify the RBL method's contribution in the early years' education of engineering students.

As can be observed, the use of RBL in theoretical and practical courses positively impacts the competencies, improving them. This was also observed in the study performed by Mayolo-Deloisa et al. [7], where through RBL strategy, students in an Enzymology and Biocatalysis course were able to generate experimental data and develop competencies for knowledge acquisition, gain a higher commitment level, and improve their research skills. Similar observations were reported by Noguez et al. [15] for undergraduate Computational Engineering students. Several approaches have been made to improve the development of technical and transversal competencies; however, not all of them showed successful results compared with traditional teaching [13].

**IV. CONCLUSIONS**

The data collected in the present study shows that the students knew about the searching tools and how to use them. However, their skills to recognize trustworthy digital sources to perform relevant scientific research were poor before taking the course employing the RBL methodology. The students' perception of their technical skills shows significant improvement. Of the transversal competencies, the students expressed feeling a higher mastery of PS and DS after the RBL. The technical competencies NT and RI show the best improvement as a result of using the RBL methodology. This proposed methodology can be extended to other types of courses. Encouraged by these results, we intend to employ the methodology in other undergraduate engineering courses and other fields, such as business and medicine, in the early stages of the students' education.

**Acknowledgments**

The authors acknowledge the financial and technical support of Writing Lab, Institute for the Future of Education, Tecnológico de Monterrey, Mexico, in the production of this work. We also acknowledge the Science Department and the Teaching Assistant Program of Tecnológico de Monterrey, Campus Puebla.



- [12] A. Wedel, C.R. Müller, J. Pfetsch, A. Ittel, Training teachers' diagnostic competence with problem-based learning: A pilot and replication study, *Teach. Teach. Educ.* 86 (2019) 102909. doi:10.1016/j.tate.2019.102909.
- [13] P. Garnjost, S.M. Brown, Undergraduate business students' perceptions of learning outcomes in problem based and faculty centered courses, *Int. J. Manag. Educ.* 16 (2018) 121–130. doi:10.1016/j.ijme.2017.12.004.
- [14] J.L. Devore, Probability and statistics for Engineering and the Sciences, in: 9th ed., CENGAGE, 2016: pp. 382–388.
- [15] J. Noguez, L. Neri, Research-based learning: a case study for engineering students, *Int. J. Interact. Des. Manuf.* 13 (2019) 1283–1295. doi:10.1007/s12008-019-00570-x.

# Solid Waste Management Strategy As An Alternative Energy Source For The Economic Driver In Gading Kasri Malang City

<sup>[1]</sup> Dwi Arman Prasetya, <sup>[2]</sup> Anwar Sanusi, <sup>[3]</sup> Grahita Chandrarin, <sup>[4]</sup> Elfiatur Roikhah, <sup>[5]</sup> Rahman Arifuddin, <sup>[6]</sup> Irfan Mujahiddin, <sup>[7]</sup> Puput Dani Prasetyo Adi

<sup>[1][5][6][7]</sup> Electrical Engineering Department, Engineering Faculty, University of Merdeka Malang, Indonesia  
<sup>[2][3][4]</sup> Economics and Business faculty, University of Merdeka Malang Indonesia

**Abstract**— The economic factor is one of the keys to an area that can be advanced and independent. Until now, the community is still dependent on expensive fuel, while using raw materials around the Gading Kasri village is the right idea. One of the pictures to improve the community's economic factor in the Gading Kasri village is how to convert waste into fuel. The benefits obtained are substantial, including helping the community's economy, reducing plastic waste, and turning plastic waste into energy that is useful for cooking, starting motorbikes, and other powers. In this research, the design of the Combustion Optimization Tool for the Distillation of Plastic Waste into Oil Fuel (BBM) was made as an effective solution to produce an energy source in the form of gas oil with a maximum volume when compared to previous designs for similar devices. In this design, a plastic waste burner cross-section is made in the form of a circular crossbar so that the volume of waste and the effectiveness of combustion that is collected can be more in work. Furthermore, this tool will be used by the community in the Gading Kasri Village to be more beneficial for the organization or the general public.

**Index Terms**— Biomass, alternative, energy, plastic, waste, distillation, gasification, economic

## I. INTRODUCTION

Final Processing Site (TPA) is a place to collect trash from several temporary shelters (TPS). In Indonesia, currently, waste processing at TPA is carried out using open dumping methods and sanitary landfills. The available dumping method has been prohibited through Law number 18 of 2008 concerning Waste Management. With the issuance of this law and to overcome the increasingly urgent waste problem, Several studies have been conducted to design a friendly waste processing technologies environment (Perini et al. 2017). Initially, many countries used incinerators or heating technology. However, incinerator technology turns out to impact the form of dioxins and furans as a result of emissions that are very harmful to the human body. To tackle the incinerator's impact, experts have now discovered processing technology for the new waste, namely methane or bio-mass fermentation technology (Yadav 2015). Biomass technology is a clean energy technology that has been agreed upon by several countries in the Kyoto Protocol to develop a clean development mechanism. Biomass is organic material produced through photosynthetic processes, either in the form of products or waste.

One technology that uses biomass to produce energy is gasification technology. The supply of biomass raw materials in Indonesia is more than the source of other alternative fuels. The only challenge faced today is the cost efficiency collection of fabrics and mobilization of materials so that production costs are not too high (Zeng, Song, and Wang 2012). This technology provides excellent benefits to society and regional development, biomass and

gasification technology growth must be accompanied by precise economic calculations (Parizeau, von Massow, and Martin 2015). The ESDM ministry's data states that the energy potential is generated from waste cities throughout Indonesia reached 49,810 MW. The current installed capacity of biomass technology only 0.89 percent.

However, waste originating from plastic materials is always the primary source of the problem because it is difficult to process it into an energy source, therefore in this design, a "Combustion Optimization Tool Design for the Distillation of Plastic Waste into Fuel" was made in this design. In this design, a plastic waste burner cross-section is made in the form of a circular crossbar so that the volume of waste and the effectiveness of combustion that is collected can be more in work.

## II. THEORY

Several theories form the basis of this research, as presented in the following points :

### 2.1 Active Carbon

Activated carbon is an amorphous compound produced from materials containing carbon or charcoal, which are specially treated to obtain high adsorption power. Activated carbon can adsorb certain gases and chemical compounds or selective adsorption properties, depending on the pores and surface area's size or volume. The absorption capacity of activated carbon is substantial, namely 25-100% by weight of activated carbon (Morrissey and Browne 2004). Activated carbon can be divided into two types, namely: 1. Activated Carbon as Blanching Usually in the form of a fine powder with a pore diameter of 1000 Å, used in the

liquid phase, and serves to remove disturbing substances. 2. Activated Carbon as a Vapor Absorbent Usually in the form of granular or very hard pellets, the diameter of the pore is 10-200 Å, generally used in the gas phase for solvent return, catalyst, and gas purification (Garner et al. 1972). In general, activated carbon/charcoal is used as a cleaning agent and absorbent and is also used as a catalyst carrier (Morrissey and Browne 2004).

**2.2 Plastic Waste**

The use of plastic material from year to year has increased and requires a large space to accommodate it. The number of plastic products produced in Indonesia consists of Poly Propylene (PP), Poly Ethylene (PE), Poly Styrene (PS), Poly Vinyl Chloride (PVC), Acrylonitrile Butadiene Styrene (ABS), Poly Ethylene Terephthalate (PET), Low-Density Poly Ethylene (LDPE), High-Density Poly Ethylene (HDPE), and Styrofoam. The products are already produced locally. Plastic products will be discarded by consumers because they are no longer used as waste. Of the various plastic waste that exists, Plastic Waste from the types of High-Density Poly Ethylene (HDPE) and Poly Propylene (PP) is the most abundant and easy to find. Some types of plastic have a market value, but most plastic snack wrap has no market value (Waste Management 2003). Source or Origin of Waste According to Wahid Iqbal and Nurul C (2009: 276), sources of waste can come from [1] Residential areas are types of waste in food scraps, leftover materials from food processing or wet waste, dry waste, and ash. [2] Public places and trade centers are places of trading activity. The type of waste produced is in food scraps, residual building materials, and others. [3] Agriculture and livestock Waste derived from animals or plants can be in the form of perishable food scraps and insect repellent materials.

**III. METHOD**

**3.1 Structural Equation Modeling (SEM)**

The analysis method uses a mixed-method, which combines the analysis of descriptive qualitative and quantitative analysis. Descriptive qualitative research was used to explain the relationship between variables based on the respondent's opinion or idea to explore the potential of the region and society. Another analysis used SEM analysis to produce influence between the variables studied so that it is expected to be part of it in making decisions for poverty reduction programs. Analysis of Structural Equation Modeling (SEM) Statistical analysis using inferential statistics to test each indicator's strength in forming a variable, so it can be known which hand dominant in developing variables, by knowing the value of the factor loading each indicator against the variable. Also, the influence between variables will be known as independent and dependent variables. The analysis used in this study uses Structural Equation Modeling (Structural Equation Model or SEM) using packages AMOS 21 and SPSS Version 11.5 programs.

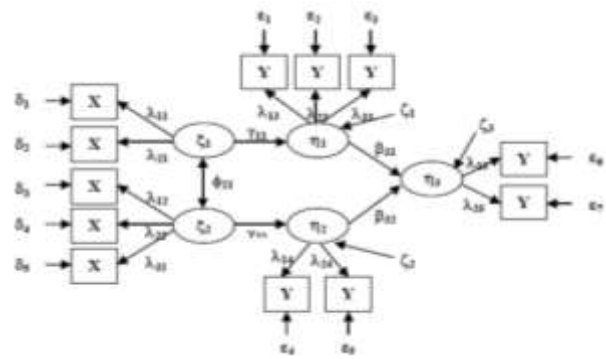

Figure 1. SEM Modeling

**3.2 Design and Specification**

This tool has the following specifications, i.e., 1. Combustion Room I, 2. Distribution Pipe I (Between Combustion Room I and Filter Room I), 3. Filter Room I, 4. Condenser I (Between Filter Room I and Combustion Room II), 5. Combustion Temperature Indicator in Combustion Room I, 6. Drainage Residual Combustion, 7. Combustion Temperature Indicator in Combustion Room II, 8. Combustion Room II, 9. Condenser II (Between Combustion Room II and Storage Room), 10. Combustion Smoke Exhaust Pipe, 11. Burning Fume Exhaust Pipe to Smoke Minimizing Room, 12. Smoke Minimizing Room (filled with water to minimize combustion smoke), 13. Shelter Room (there is also a filter), 14. Faucets

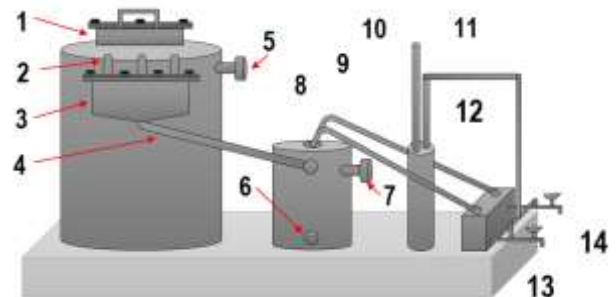

Figure 2. prototype design to convert plastic into fuel

The stages of the process can be seen at the following points, [1] The first thing that must be done is sorting plastic waste because the type of plastic waste that will be processed will affect the output of the fuel to be released (clarity level). Plastic waste must be cleaned before burning. A suitable type of plastic waste for this tool is plastic waste from drinking mineral water bottles. [2] After sorting plastic scrap, plastic waste should be crushed into plastic ore because the firing process will be more optimal (there will be no plastic residue in the combustion chamber). The combustion capacity of this tool is + 10 kg. [3] Enter the plastic waste that has been crushed into Combustion Room I (+ 10Kg capacity) before burning the previous combustion exhaust in the drain. After there is no remaining combustion before, combustion can be carried out. The temperature in the combustion chamber, expected to be maximum (maximum temperature indicator). [4]

Steam from combustion in the combustion room I will enter Filter Room I, Filter Room I contains activated charcoal, which can be replaced every six months. This activated charcoal is readily available at aquarium stores. [5] After passing through Filter Room I, the money from combustion will enter combustion room II. In this combustion room II the expected temperature is not more than 50 ° C. From combustion chamber II, the money from combustion will enter the Filter Room plus the Storage Room. [6] From the storage room, there is a channel to channel the smoke from the combustion residue to the Smoke Minimizing Room to minimize combustion smoke. [7] A Cooling Pipe reduces the heat from the combustion oil before it is distributed to the storage room. [8] There are two faucets in the storage room to channel oil from the storage room to the next reservoir.

IV. RESULT

4.1 Testing of The Prototype

In this section, a trial will be carried out by entering the raw material for plastic waste. In this section, the plastics will be smelted to produce fuel. The amount of plastic will determine how many liters of energy are produced.



Figure 3. prototype succeeded in producing fuel

4.2 Analyzes

Table 1. Experiment for Recycling of Clear Plastic Waste from Mineral Water Bottles

Nu	Number of experiment	Garbage weight	Temperature (C)	Burning time (minute)	Fuel Type A (ml)	Fuel Type B (ml)	Fuel Type C (ml)
1	1	10	300	118	240	702	134
2	2	10	285	122	251	735	140
3	3	10	260	127	218	636	123
4	4	10	303	113	253	741	141
5	5	10	254	131	211	615	120
6	6	10	257	129	217	633	123
7	7	10	283	125	231	675	130
8	8	10	251	136	212	618	120
9	9	10	253	130	209	609	119
10	10	10	274	126	233	681	131
11	11	10	252	137	215	627	122
12	12	10	250	135	210	612	119
13	13	10	255	131	211	615	120
14	14	10	252	140	198	576	113
15	15	10	247	136	208	606	118

Table 2. The Experiment for Recycling of Cooking Oil Packaging Plastic Waste

Nu	Number of experiment	Garbage weight	Temperature (C)	Burning time (minute)	Fuel Type A (ml)	Fuel Type B (ml)	Fuel Type C (ml)
1	1	10	250	190	151	481	163
2	2	10	200	253	160	508	167
3	3	10	210	246	149	475	162
4	4	10	208	255	168	532	171
5	5	10	254	187	115	373	145
6	6	10	226	206	147	469	161
7	7	10	200	260	154	490	164
8	8	10	200	242	165	524	170

9	9	10	260	181	287	890	231
10	10	10	243	205	237	739	206
11	11	10	200	245	163	518	169
12	12	10	248	180	276	855	225
13	13	10	260	185	281	871	228
14	14	10	210	240	175	553	175
15	15	10	230	208	221	691	198

Table 3. Experiment on recycling various types of plastics

Nu	Number of experiment	Garbage weight	Temperature (C)	Burning time (minute)	Fuel Type A (ml)	Fuel Type B (ml)	Fuel Type C (ml)
1	1	10	200	220	109	355	170
2	2	10	200	218	110	358	170
3	3	10	210	203	124	400	177
4	4	10	208	210	119	385	174
5	5	10	254	135	226	705	228
6	6	10	226	186	146	465	188
7	7	10	200	230	104	341	167
8	8	10	200	225	107	348	168
9	9	10	260	127	246	765	238
10	10	10	243	142	205	644	218
11	11	10	200	227	106	345	168
12	12	10	248	138	216	675	223
13	13	10	260	123	254	789	242
14	14	10	210	210	120	388	175
15	15	10	230	217	127	410	179

5.2 Comparison graph of output results in milliliters (ml) of 3 different types of fuel

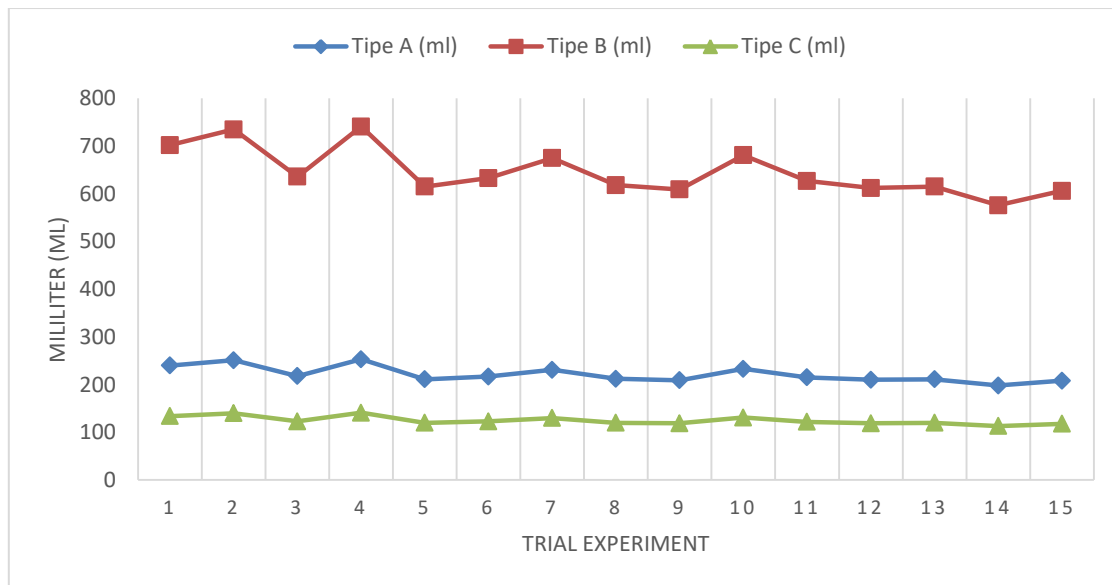

Figure 4. The experiment used a 10 kg drinking bottle or mineral water

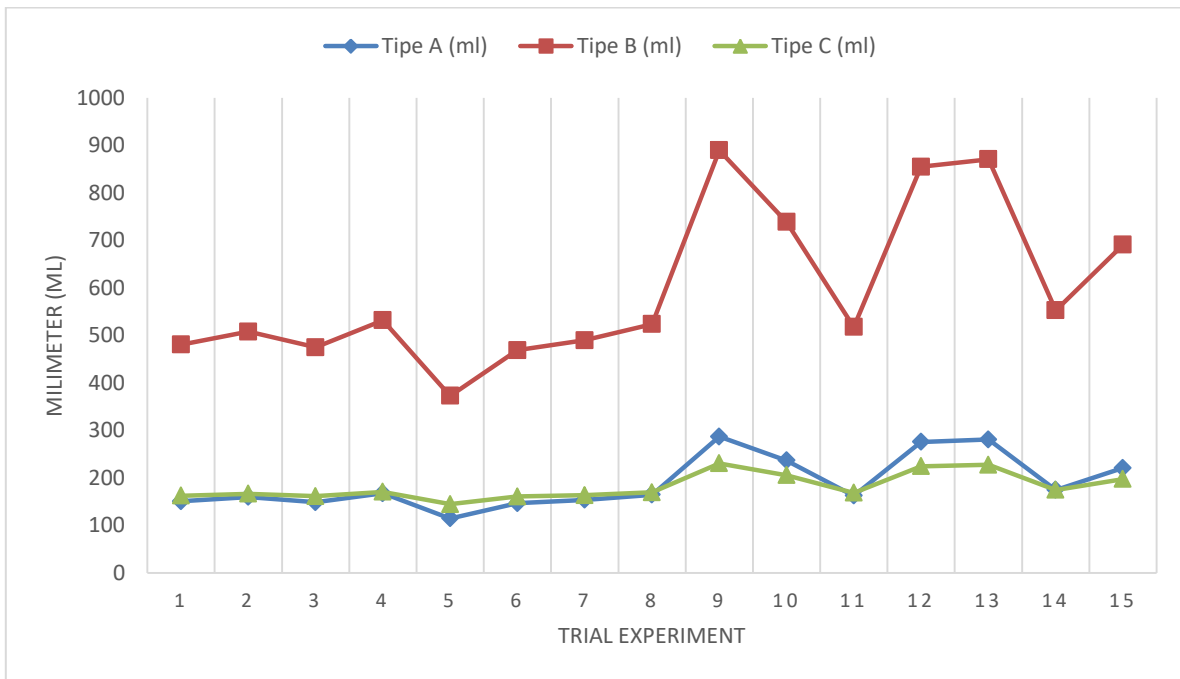

Figure 5. The experiment used 10 kg of cooking oil plastic waste

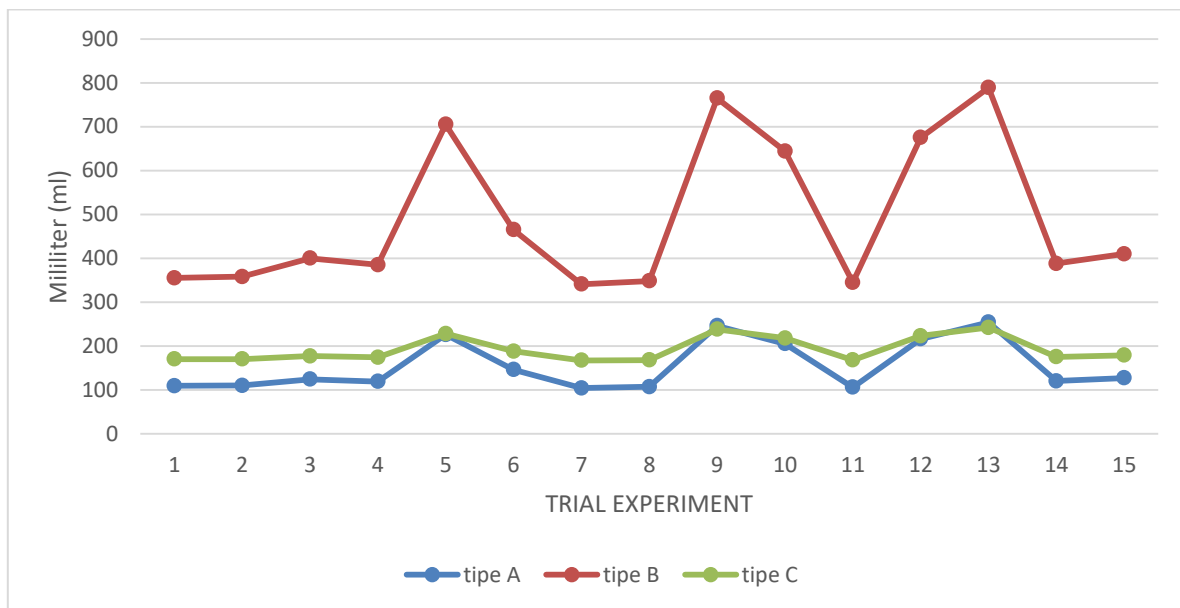

Figure 6. Experiment with various 10 kg plastic waste

V. CONCLUSION

Produce an energy source in the form of gasoil with a maximum volume compared to previous designs in similar devices. The fuel produced by this tool can be used to fuel lawnmowers and two-stroke motorcycle engines. It is essential to pay attention to sorting plastics before burning. The best is plastic waste from mineral water bottles. The main components consisting of Combustion Room I, Filter Room I, Combustion Room II, Filter Room + Storage Room, Smoke Minimizing Room. Furthermore, The fuel produced by the tool made in this research is successful.

The fuel produced needs a further refining process to deliver maximum filtering results to be used in cars and similar vehicles.

REFERENCES

[1] senberg, D., 2011a, *The Entrepreneurship Ecosystem Strategy as a New Pradigm for Economy Policy: Principles for Cultivating Entrepreneurship*, Babson Entrepreneurship Ecosystem Project, Babson College, Babson Park: MA



- [2] Japan Institute of Energy, 2012, *Asia Biomass Handbook*, Japan, JIE
- [3] Korhalliler, S., 2010, *The UK's Biomass Energy Development Path*, UK: International Institute for Environment and Development
- [4] Lazear, Edward P., 2005, *Entrepreneurship, Journal of Labor Economics*, 2005, vol 23, no 4.
- [5] Pahuja, A. and Sanjeev, R., 2016, *Introduction to Entrepreneurship*, Ghaziabad: IMS
- [6] Ramke, Hans Gunter, et al., 2009, *Hydrothermal Carbonization of Organic Waste*, Prosiding Seminar "Twelfth International Waste Management and Sanitary Symposium, Italy: CISA Ppublisher
- [7] Tajali, Arief, 2015, *Panduan Penilaian Potensi Biomasa Sebagai Sumber Energi Alternatif di Indonesia*, Jakarta: Penabulu Alliance
- [8] Brunner, Paul H., and Helmut Rechberger. 2015. "Waste to Energy - Key Element for Sustainable Waste Management." *Waste Management*.
- [9] Garner, William et al. 1972. "WASTE MANAGEMENT RESEARCH."
- [10] Morrissey, A. J., and J. Browne. 2004. "Waste Management Models and Their Application to Sustainable Waste Management." In *Waste Management*.
- [11] Parizeau, Kate, Mike von Massow, and Ralph Martin. 2015. "Household-Level Dynamics of Food Waste Production and Related Beliefs, Attitudes, and Behaviours in Guelph, Ontario." *Waste Management*.
- [12] Perini, João Angelo de Lima et al. 2017. "Optimisation of the Removal Conditions for Heavy Metals from Water: A Comparison between Steel Furnace Slag and CeO<sub>2</sub> nanoparticles." *Arabian Journal of Chemistry*.
- [13] Waste Management. 2003. "Typical Anatomy of a Landfill." *Wm*.
- [14] Yadav, Reshu. 2015. "Solid Waste Management." *Pollution Research*.
- [15] Zeng, Zhao Xi, Bing Xue Song, and Qin Tao Wang. 2012. "A Literature Review on the Research of Circular Economy-Based Green MICE." *Advanced Materials Research*.



# Factors Influence The Use Of Social Media For Environmental Sustainability Awareness In HEI

<sup>[1]</sup> Abeer Abdullah Abdulmajid Mohammed, <sup>[2]</sup> Dr.PDD.Dominic

<sup>[1][2]</sup> Computer and Information Sciences Department (CIS) Universiti Teknologi Petronas, Bandar Seri Iskandar, Malaysia  
Email: <sup>[1]</sup> abeer\_18003041@ utp.edu.my, <sup>[2]</sup> dhanapal\_d@utp.edu.my

**Abstract**— Planet earth is our home. And it has been suffering for a long time. Many issues are threatening its existence and the existence of all kinds of lives on it. However, many efforts are made to reduce these threats by achieving Sustainable Development (SD), among those efforts Agenda 2030. Agenda 2030 targets to raise awareness and share the needed information regarding SD everywhere by 2030. Environmental sustainability is a dimension of sustainable development. Environmental sustainability awareness is low in many countries. Therefore, in contribution to Agenda 2030 and SD, there is a need to raise awareness regarding environmental sustainability. Social media technologies are adequate tools to raise awareness and share the required information. Moreover, 60% of the world population uses social media. However, some factors influence their usage. So, this research is going to study the factors that influence the use of social media for environmental sustainability awareness in Higher Education Institutes (HEIs). Besides, HEIs are considered centers to promote SD information sharing and dissemination. And they are important sectors that can educate and increase awareness of multi- stakeholders. The research objective is to identify the factors. Then evaluate their influence on the use of social media for environmental sustainability awareness in HEIs. To evaluate their influence, the 'quantitative research method' is going to be used. Then measures are going to be identified. A questionnaire will be designed. After that, data is going to be collected from participants using the questionnaire. Participants are multi-stakeholders in HEIs in Malaysia. Such as students, staff and, administrators. 'Stratified sampling' to be used for sampling. This study is part of a framework for higher education institutions to use social media effectively to increase environmental awareness. It will also contribute toward achieving Sustainable development. The 'Framework and relationships' will be evaluated using SPSS and Structural Equation Modeling (SEM).

**Index Terms**— Environmental awareness, Environmental sustainability, Higher Education, HEI, Social media

## I. INTRODUCTION

Sustainable development (SD) is a plan that covers present needs without sacrificing future generations' opportunities to fulfill their own needs [1]. Everyone has to contribute towards SD. As Agenda 21 mentioned that to get our basic requirements, improve life, protect the environment, and for a better future, the whole world has to be concerned about both the environment and development [2].

The 2030 Agenda for SD consists of 17 SD Goals and 169 targets to achieve the three dimensions of SD – Social, Economic, and Environmental sustainability [3]. Agenda 2030 complete the Millennium Development Goals (MDG). MDG7 was introduced to ensure environmental sustainability. Environmental sustainability is meeting the demands of present and future generations with resources and services without sacrificing the sustainability of the environments that provide them [4].

In all areas of Agenda 21, the promotion of education, public awareness-raising, and training are specifically mentioned. Besides, chapter 36 of the Agenda broadly addresses this matter. One of the aims is to achieve environmental awareness in all sectors worldwide. Moreover, Universities could be centers to promote information sharing and dissemination. Again in 'the future, we want' United Nations conference on sustainable development indicates the importance of information

dissemination and sharing and raising public awareness in environmental issues.

There is an increase in the use of social media to raise awareness regarding sustainable development [5]. Trying to integrate SD into social networks increases the credibility of the discussion and gives new meaning to the current ideas. [6]. However, there is a lack of research on the use of social media in HE to disseminate information and create awareness of environmental sustainability. Also, no framework to properly benefit from social media for creating environmental sustainability awareness in higher education [7]. The research question raised is:

1. What factors influence the use of social media for environmental sustainability awareness in HEIs?

### A. Problem Statement:

Environmental Awareness is low in many countries. There is a need to raise environmental sustainability awareness to achieve agenda 2030 goals as goal 12.8 is to ensure people everywhere have sustainable development information and Awareness by 2030.

Making use of the widespread of social media to increase knowledge about environmental sustainability in Higher Education and others is needed [7, 8].

Social Media use is influenced by some factors. Identifying those factors is needed to make an effective use of social media. Therefore, this research will study the factors that

influence the use of social media for environmental sustainability awareness in HEIs. Then provide recommendations.

### B. Research Objectives

1. To identify the factors that influence the use of social media for environmental sustainability awareness in HEIs.
2. To evaluate the framework using appropriate tools and techniques.

## II. LITERATURE REVIEW

There is a need to raise awareness regarding environmental issues to increase green practices, as a study by [9] to investigate Environmental health awareness among students found that only half of them have a good knowledge regarding environmental health. And it suggests that students who are more aware have better potential to participate in green practices. [10] and [11] support this idea. They indicate a significant relationship between awareness and environmental practices. Environmental awareness is called the process by which humans absorb, understand, store, and organize information within the environment [12]. In conclusion, HEIs can be used to increase people's awareness regarding environmental issues, which is going to lead to encouraging people into maintaining environmentally friendly practices, therefore contributing to solving those issues.

### A. Social Media and Environmental awareness

Internet media - video sharing, blogs, podcasts, etc. - is a platform of mass [13]. According to [14], Mass media can be responsible for improving the environmental awareness of students. Moreover, [15] suggests for Environmental Awareness, educating students should be through media because media can serve as a forum to discuss important issues and provide education and information [13]. Besides, according to [16], it is an adequate tool in the acquisition of knowledge. A study also suggests to transmit environmental information and promote positive environmental attitudes. There should be more use of media [17]. Those studies illustrate the importance of using media as a source of knowledge and for sharing information regarding the environment. Therefore, it can increase awareness and positively influence the attitude and behavior toward the ecosystem.

A study recommends the use of emerging media technology such as micro-video, microblogs, and other social media to encourage university education on ocean environmental awareness [18]. Similarly, another research report that utilizes media can be an appropriate medium to encourage environmental awareness. Besides, it recommends more studies should be done on using the internet to effectively create Environmental awareness as the internet has the fastest way to disseminate information [19]. A study of sustainable development in HE reports social media to offer chances for informal learning and social capital building.

Also, as a source of information, social media is a significant predictor for teaching methods, a sustainable lifestyle, and behavioral intention [12]. Besides, social media plays an adequate role in university students learning behavior in pursuing sustainable education, and students like to use social media to create awareness and get useful information [20]. Therefore, social media has excellent technologies that can be used to raise awareness of environmental sustainability in HEIs. Also, it can be used in many ways to raise awareness through teaching, learning, sharing, communicating, etc.

Some research study the impact of social media campaigns on Environmental awareness in HEIs. The campaign is used to share Environmental information to make awareness by measuring awareness before and after [21, 22]. Another study used the uses and gratifications (U&G) theory for social media campaign usage for extra-curricular education. Then, it evaluated the usage before and after the campaign [23]. The use and acceptance of social media campaigns have a huge effect on the environmental knowledge of participants, which also affects Environmental awareness [23]. Also, through using social media to conduct an environmental campaign, a study indicates a rise in awareness about environmental problems and positive attitudes [24]. These studies usually show that the use of SM to raise Environmental awareness is done through the campaign. It also can be done through environmental education.

### B. Higher Education Institutes

[10] indicates that communities are not well receiving environmental awareness programs through social media. However, studies have been done to investigate how social media campaigns can be used to create environmental awareness in HEIs. Other studies research the social technology role in HEIs as a tool to disseminate awareness to deliver environmental education. However, there is a gap in the literature in addressing how effectively SM can be used to increase environmental sustainability awareness and the vision for sustainable development in HEIs. As when it comes to Environmental sustainability awareness in HEIs, it is usually making use of social media as a campaign to discuss environmental issues such as [23] [21] [22]. The study is going to cover the gap by finding a proper way to benefit from SM to create ES awareness in HEIs. The first objective - which is the objective of this study - is identifying the factors that influence the usage of SM. Then investigate the SM and ways in which used for ES awareness in HEIs. And develop the appropriate framework.

### C. Factors Influence The Use Of Social Media

Using social media is influenced by some factors. Some factors have positive effects, while others have negative effects. There is a need to find what factors positively influence the use of SM so they could be maintained to make effective use. In HEIs, SM is used in many ways, such as teaching, learning, communication, research,

business, etc. And studies are done to find the factors that influence their usage. Studies find Performance expectancy, Effort Expectancy, Social influence, Facilitating conditions have a positive influence on using SM in HEIs [25] [26] [27] [28] [29] [30] [31] [32] [33] while others find no significant or negative relation [25] [27] [28] [32] [33].

[25] found that Intrinsic value has a positive and significant effect. Peer influence & Social media conditions also have a positive influence on [26]. Moreover, [29] identified Management support, Adequate resources, Adequate training, and Introducing a champion to be critical success factors. [21] also found Management Support is needed in

the SM awareness campaign. [34] found in his study to explore the SM factors to increase environmental awareness are Perceived trust, Persuasive Power, Perceived Reliability, Ease of Accessibility, and Promptness of Activism. Also, the User's Involvement can motivate users. And this is supported by [22] findings. [31] also found Perceived trust to be an influencing factor besides Perceived risk and Perceived enjoyment. Coordination, Social presence, and Ease of Accessibility do influence the use of SM campaigns for environmental knowledge [23]. Besides, Time, Attitude, and Fast internet connection has the same influence [23] [22].

**Table 1. Factors influence the use of Social Media**

Authors	Khechine (2020)	Awotunde (2019)	Seedat (2019)	Sánchez-Holgado (2019)	Murire (2019)	Severo (2019)	Surachim (2018)	Kaur (2018)	Nawi (2017)	Scholtz (2017)	Lenoir (2017)	Scholtz (2016)	Tlebere (2016)	Jung (2015)	Ballew (2015)	Hutter (2013)	Gruzid (2012)	Total
Performance expectancy	*	*	*	*	*		*		*					*			*	9
Effort expectancy	*	*	*	*	*		*							*			*	8
Social influence	*	*	*	*	*		*							*			*	8
Facilitating conditions	*				*		*	*					*				*	6
Intrinsic value	*																	1
Peer influence		*																1
Social media conditions		*																1
Management support					*						*							2
Adequate resources					*													1
Adequate training					*													1
Introduce a champion					*													1
Perceived trust								*	*						*			3
Perceived risk									*									1
Perceived enjoyment									*									1
User Involvement / Engagement								*		*	*	*			*			4
Engaging content						*					*	*			*			3
Well-presented information											*	*		*				2
Coordination										*								1
Social presence										*								1
Time										*		*						2
Attitude										*		*						2
Fast internet connection										*		*						2
Internet usage												*						1
User background												*		*				2
Goals and objectives												*		*				2
Social media selection												*						1
Readiness & change management												*						1
Value metrics												*						1
Duration of programme												*						1
Frequent information updates												*						1
Authenticity												*						1
Persuasive Power								*										1
Perceived Reliability								*										1

Ease of Accessibility							*		*											2	
Promptness of Activism / actions						*		*													2
Social marketing										*											1
Preferences															*						1
Tailored to the populations															*						1
Conveys personal relevance															*						1
Mutual collaboration															*						1
People's access															*						1
Note	HEI	HEI	HEI	HEI	HEI	(Environmental Awareness and the Social Responsibility)	HEI	HEI (environmental awareness & behavior)	HEI	HEI	Cancer awareness	HEI (Sustainable Practices)	HEI (Environmental knowledge)	HEI	(Foster Proenvironmental Action)	Brand awareness	HEI				

[22] also found Internet usage, User background, Goals and objectives, Social media selection, Readiness & change management, Value metrics, Duration of program, Frequent information updates, and Authenticity to be a critical success factor in the SM awareness campaign. Engaging content and Well-presented information also are needed in such campaigns [21].

Other studies also found factors influence using SM in a context other than HEIs for environmental issues or awareness overall. Research on the influence of SNS on environmental awareness & social responsibility recommends promoting actions and information and engage users in SD [35]. Exposing users to information positively influence their Environmental awareness.

Also, [36] in a study of using SM to foster pro-environmental actions recognized that technologies' effectiveness depends on people's access, needs, skills, preferences, and experience. And SM technologies can be productive if they are engaging and tailored to people's interests. Besides, effective communication should have a well-crafted message, convey personal relevance, a source that builds trust and Mutual collaboration with users. In a study of raising awareness about cervical cancer, it suggested that social media campaign depends on users involvement and social marketing [37]. This suggestion is supported by another study, which indicates that user engagement in SM has positive effects on brand awareness, while annoyance has a negative impact [38]. In the above, Table 1 lists some factors that influence the use of social media in HEIs, in other contexts of environmental issues and awareness overall.

### III. PROPOSED RESEARCH FRAMEWORK

#### A. Theoretical Background

The objective of this study is to identify the factors that influence the use of social media technologies. Recent work has found the Unified Theory of Acceptance and Use of Technology (UTAUT) to be popular in the evaluation of acceptance, diffusion, and usage issues of technologies in IS/IT [31, 33]. It is one of the most predictive models in the technology acceptance literature to explain the effective use of technology [39] [25]. UTAUT is used to explain the individuals' acceptance and use of technologies in organizations. Studies used this theory to evaluate the use of social media in higher education for education, teaching, learning, communication. etc. [25] [26] [29] [28] [27] [30]

[31] [32] [33].

This theory integrates elements of eight models named (the Social Cognitive Theory SCT, the Innovation Diffusion Theory IDT, the Model of PC Utilization MPCU, the Motivational Model MM, the Theory of Reasoned Action TRA, the Technology Acceptance Model TAM, the Theory of Planned Behavior TPB, and C-TAM-TPB). It explains up to 70% of the variance of usage behavior [40]. This benefit has made the UTAUT model the best conceptual framework to describe intention, adoption, and use of information technology in organizations. This theory allowed researchers to get a more comprehensive prediction of user behavior than previous models [39]. It consists of four constructs: performance & effort expectancy, social influence, and facilitating conditions, as shown in Fig. 1 [40].



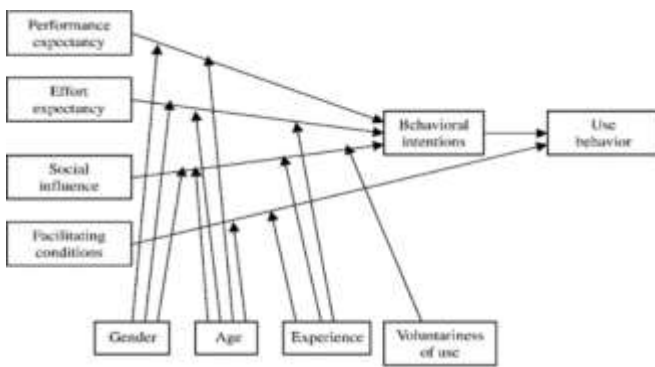

**Fig. 1. Unified Theory of Acceptance and Use of Technology (UTAUT)**

To evaluate the factors, influence the use of social media, the mediator variable “behavioral intentions” will be removed to study direct effect. Some studies also used it to evaluate the direct effect [26, 31]. This study aims to identify the factors but not the moderators. So, moderating variables are out of the aim of this study. Therefore, they are going to be dropped as a study suggested to reconsider the moderating variables of UTAUT and consider only the direct effect. It is concluded based on the majority of studies that didn’t examine moderators of UTAUT [41]. Also, many studies used UTAUT without the moderating variables in evaluating the use of social media in HEIs, such as [25] [26] [27] [30] [31] [32] [33]. And still find it appropriate.

We can conclude that UTAUT is the most appropriate theory comparing to the other Theories - of acceptance and use of technologies - to study the use of social media in HEIs. Considering the positive influence of its factors in the use of SM and other technologies. More factors will need to be investigated.

**B. Hypotheses:**

**UTAUT factors:**

Performance Expectancy is how the user think that performance will be better by using the social media [40]. Studies find Performance expectancy has a positive influence on the intention / actual use of social media in HEIs for teaching, learning, Education or communication [26] [29] [28] [27] [30] [31] [32] [33]. Therefore, the proposed hypothesis is.

**H1:** Performance expectancy positively influences the use of social media for environmental sustainability awareness.

Effort Expectancy is how easy to use social media [40]. Some studies find Effort expectancy has a positive influence on the intention / actual use of social media in HEIs for teaching, learning, Education or communication [26, 29] [30]. Therefore, the proposed hypothesis is.

**H2:** Effort expectancy positively influences the use of social media for environmental sustainability awareness.

Social Influence is how others thinking of the importance of user should use social media influence the user thinking [40]. Studies find Social influence has a positive influence on the intention / actual use of social media in HEIs for teaching, learning, Education or communication [26] [29] [28] [27] [30] [32] [33]. Therefore, the proposed hypothesis is.

**H3:** Social influence positively influences the use of social media for environmental sustainability awareness

Facilitating Conditions is how users think of the existing facilities will support the use of social media [40]. Studies find Facilitating conditions have a positive influence on the intention / actual use of social media in HEIs for teaching, learning, Education or communication [25] [29] [30] [31] [32]. Therefore, the proposed hypothesis is.

**H4:** Facilitating conditions positively influences the use of social media for environmental sustainability awareness.

**Other factors:**

Attitude is how the user feels about using social media [42]. It is derived from many theories such as TRA, TPB, C-TAM-TPB, TAM, etc.. as shown in Fig. 2 and Fig. 3. It is one of the most frequently used external variables to UTAUT [43]. Attitude has a significant role in IS/IT use and acceptance. Moreover, it has a direct impact on user usage behavior[41]. It influences the usage and acceptance of social media [23]. Increasing positive attitudes toward ICT will improve the integration of social media and reduce the resistance to use the technologies[29]. Investigating more factors is needed. And studies should be done to get more knowledge of attitudes towards social media sustainable usage [20]. UTAUT found attitude has no significant effect on using technology, but other studies consider it as an influencer [20] [23] [29] [41] [43]. Therefore, the proposed hypothesis is.

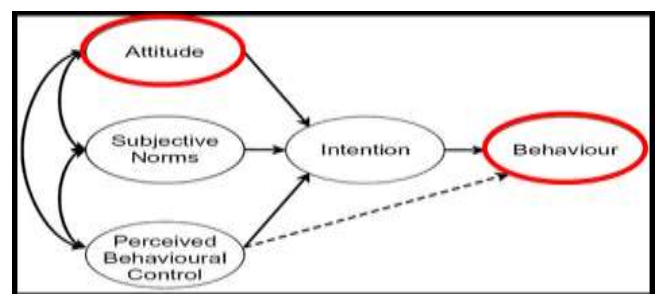

**Fig. 2. The Theory of Planned Behaviors (TPB)**

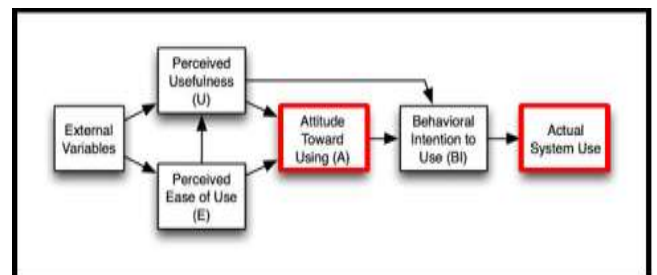

**Fig. 3. Technology Acceptance Model (TAM)**

**H5:** Attitude positively influences the use of social media for environmental sustainability awareness.

[29] indicates that Management support is a critical success factor in using social media at universities. This indication is also supported by [21], where it explained the need for Management support for the campaign that uses social media for environmental awareness. Therefore, the proposed hypothesis is.

**H6:** Management support positively influences the use of social media for environmental sustainability awareness.

[21] finds a campaign that uses social media for environmental awareness needs Engaging content. Another study on the influence of Social networks on environmental awareness suggests that information should be engaging [35]. [36] also finds that Social media use for environmental action could be more effective when they are engaging. Therefore, the proposed hypothesis is.

**H7:** Perceived trust influences the use of social media for environmental sustainability awareness.

[21] finds a campaign that uses social media for environmental awareness needs Well-presented information. [36] also finds that Social media use for environmental action could be more effective when the information is well presented. Therefore, the proposed hypothesis is.

**H8:** Engaging content positively influences the use of social media for environmental sustainability awareness.

[36] indicates communication could be effective when there is trust between both sides. Perceived Trust affects the use of SM in HEIs for environmental awareness or others [34] [31]. Therefore, the proposed hypothesis is.

**H9:** well-presented information positively influences the use of social media for environmental sustainability awareness.

[34] finds User’s Involvement in Social networks can motivate them towards environmental issues. And according to [22], it is a critical success factor for social media awareness campaign. [37] and [38] also finds the involvement and engagement of users in social media has a positive effect on awareness. Therefore, the proposed hypothesis is.

**H10:** User Involvement positively influences the use of social media for environmental sustainability awareness.

Therefore, this study is considering the influence of UTAUT theory - performance expectancy, effort expectancy, social influence, and facilitating conditions- and other factors on using social media for environmental sustainability awareness in HEIs. Fig. 4 shows the proposed framework.

**IV. RESEARCH METHODOLOGY**

This research will identify the factors that influence the usage of social media for environmental sustainability awareness in HEIs. Then the proposed framework is going to be evaluated.

**A. Method:**

For evaluating the influence of the factors using the proposed framework, the quantitative research method is going to be used. Then measures are going to be identified. After that, data is going to be collected based on them. And statistical analysis will be conducted to report relationships among them. For implementing and validate the framework, a questionnaire is going to be used to collect data. The questionnaire will be distributed to participants. Participants are students, staff, and administrators - multi-stakeholders - in HEIs in Malaysia. Study places - such as universities - must be researched as multi-stakeholders sophisticated and complex units [44]. Malaysia, HE has more than 100 public and private institutes. For sampling, probabilistic sampling is going to be used in this research. Accurately, Stratified sampling to select three public and three private universities. The questioner will be prepared and verified with experts. Before the final data collection, a pilot study will be carried out and evaluated. Next, the measurement's items are going to be verified. After the verification, targets are going to be approached for actual data collection where the questionnaire is going to be distributed through Electronic, Delivery, and Direct Survey Method. Then they will be collected back.



**Fig. 4: Proposed Research Framework**

Then the data will be analyzed using Statistical Package for the Social Sciences (SPSS) and Structural Equation Modeling (SEM). SEM is a statistical method used to evaluate and estimate structural relationships between measured variables and latent constructs. First, Descriptive Analysis, Validity, and Reliability Analysis and Model Fitness are going to be carried out. After that, hypotheses are going to be tested. Then results are going to be Interpreted. Discussion, Conclusion, and Recommendations will be made and then Finally Reporting.



## V. EXPECTED PRACTICAL AND THEORETICAL CONTRIBUTIONS

Practically, this research will propose ideas to enhance the use of social media to increase environmental sustainability awareness by users in HEIs. With the recommendations, different HEIs stakeholders can use them in a better way.

The theoretical contribution of this research being part of a framework for higher education institutions to use social media effectively to increase environmental awareness.

## VI. CONCLUSION

Social media technologies are widely used all over the world. And the number of users is increasing day by day. They are also adequate tools to raise awareness and reach so many people. However, some factors influence the use of social media. In contribution to the target of raising sustainable development awareness - in particular environmental sustainability awareness - by 2030. This research will study the factors that influence the usage of social media for Environmental Sustainability Awareness in Higher Education Institutes. It is a part of a framework for Higher Education Institutes to use social media in an effective way to increase environmental sustainability awareness.

## REFERENCES

- [1] Imperatives, S., *Report of the World Commission on Environment and Development: Our common future*. Accessed Feb, 1987. **10**.
- [2] Sitarz, D., *Agenda 21: The earth summit strategy to save our planet*. 1993.
- [3] Desa, U., *Transforming our world: The 2030 agenda for sustainable development*. 2016.
- [4] Morelli, J., *Environmental sustainability: A definition for environmental professionals*. Journal of environmental sustainability, 2011. **1**(1): p. 2.
- [5] Buckler, C. and H. Creech, *Shaping the future we want: UN Decade of Education for Sustainable Development; final report*. 2014: Unesco.
- [6] Kolleck, N., G. De Haan, and R. Fischbach, *Social networks for path creation: Education for sustainable development matters*. Journal of Futures Studies, 2011. **15**(4): p. 77-92.
- [7] Hamid, S., M. Ijab, H. Sulaiman, R. Md Anwar, and A. Norman, *Social media for environmental sustainability awareness in higher education*. International Journal of Sustainability in Higher Education, 2017. **18**: p. 474-491.
- [8] Meschede, C. and M. Henkel, *Library and information science and sustainable development: a structured literature review*. Journal of Documentation, 2019.
- [9] Tiong, C.S., Q.Y. Lean, L.C. Ming, A.H.B. Abdullah, S.R. Mahalingam, K. Arshad, and L.S. Hock, *Knowledge, perceptions of risks, attitudes and practices of environmental health among university students in northern Malaysia*. International Journal of Health Promotion and Education, 2020: p. 1-12.
- [10] Jusoh, S., M.k.a. Kamarudin, N. Wahab, M. Saad, N. Rohizat, and N. Mat, *Environmental Awareness Level Among University Students in Malaysia: A Review*. International Journal of Engineering & Technology, 2018. **7**: p. 28.
- [11] Omran, A., M. Bah, and A.H. Baharuddin, *Investigating the Level of Environmental Awareness and Practices on Recycling of Solid Wastes at University's Campus in Malaysia*. Journal of Environmental Management & Tourism, 2017. **8**(3 (19)): p. 554-566.
- [12] Istenic Starcic, A., M. Terlevic, L. Lin, and M. Lebenicnik, *Designing Learning for Sustainable Development: Digital Practices as Boundary Crossers and Predictors of Sustainable Lifestyles*. Sustainability, 2018. **10**(6): p. 2030.
- [13] Anonymous, *Understanding media and culture : an introduction to mass communication*. Minneapolis: University of Minnesota Libraries., 2016.
- [14] Gules Bal, H. and G. Karakas, *Environmental Education at Faculty of Agriculture and Changing Awareness, Attitude and Behavior towards Environment in Turkey*. Journal of Agricultural Science and Technology, 2018. **20**(5): p. 869-882.
- [15] Gümürkçüoğlu, N., D. Sarimehmet, and S. Hintistan, *Environmental Awareness and Knowledge Level of Higher Education Students*. Online Submission, 2017.
- [16] Bilgin, A. and N. Balkaya, *An assessment of the perspectives of university students on environmental issues in Turkey*. Fresenius Environmental Bulletin, 2017. **26**: p. 5271-5282.
- [17] Aminrad, Z., S. Zakaria, and A.S. Hadi, *Influence of age and level of education on environmental awareness and attitude: case study on Iranian students in Malaysian Universities*. The Social Sciences, 2011. **6**(1): p. 15-19.
- [18] Umuhire, M.L. and Q. Fang, *Method and application of ocean environmental awareness measurement: Lessons learnt from university students of China*. Marine pollution bulletin, 2016. **102**(2): p. 289-294.
- [19] SALEH, W., *The Role Of Mass Media In Creating Environmental Sustainability Awareness In Libya*. Thesis, 2019.
- [20] Abbas, J., J. Aman, M. Nurunnabi, and S. Bano, *The impact of social media on learning behavior for sustainable education: evidence of students from selected universities in Pakistan*. Sustainability, 2019. **11**(6): p. 1683.
- [21] Scholtz, B., C. Burger, and M. Zita, *A social media environmental awareness campaign to promote sustainable practices in educational environments, in Advances and new trends in environmental and energy informatics*. 2016, Springer. p. 355-369.
- [22] Tlebere, T., B. Scholtz, and A.P. Calitz, *Using social media to improve environmental awareness in higher education institutions, in Information Technology in*

- Environmental Engineering*. 2016, Springer. p. 101-111.
- [23] Scholtz, B., A.P. Calitz, and T. Tlebere, *Evaluating students' social media use for extra-curricular education*. Journal of Applied Research in Higher Education, 2017.
- [24] Zita, M., C. Burger, and B. Scholtz. *The Use of Social Media as an Enabler to Create Environmental Awareness of Staff in Higher Education*. in *EnviroInfo*. 2014.
- [25] Khechine, H., B. Raymond, and M. Augier, *The adoption of a social learning system: Intrinsic value in the UTAUT model*. British Journal of Educational Technology, 2020.
- [26] Awotunde, J.B., R.O. Ogundokun, F.E. Ayo, G.J. Ajamu, E.A. Adeniyi, and E.O. Ogundokun. *Social Media Acceptance and Use Among University Students for Learning Purpose Using UTAUT Model*. in *International Conference on Information Systems Architecture and Technology*. 2019. Springer.
- [27] Seedat, Y., S. Roodt, and S.D. Mwapwele. *How South African University Information Systems Students Are Using Social Media*. in *International Conference on Social Implications of Computers in Developing Countries*. 2019. Springer.
- [28] Sánchez-Holgado, P., D. Blanco-Herrero, C. Arcila-Calderón, and F.J. Frutos. *Adoption of social media for scientific communication by PhD students: The case of the PhD in Education in the Knowledge Society*. in *Proceedings of the Seventh International Conference on Technological Ecosystems for Enhancing Multiculturality*. 2019. ACM.
- [29] Murire, O. and L. Cilliers, *Critical success factors to improve the adoption of social media in teaching and learning: A case study at a traditional university*. 2019.
- [30] Surachim, A., R. Hurriyati, L. Lisnawati, S. Sulastri, and H. Mulyadi, *Using Social Media to Promote Student Entrepreneurship*. Pertanika Journal Of Social Science And Humanities, 2018. **26**: p. 173-183.
- [31] Nawi, N.B.C., A. Al Mamun, N.A.B.M. Nasir, N.B.A. Raston, and S.A. Fazal, *Acceptance and usage of social media as a platform among student entrepreneurs*. Journal of Small Business and Enterprise Development, 2017.
- [32] Jung, I. and Y. Lee, *YouTube acceptance by university educators and students: a cross-cultural perspective*. Innovations in education and teaching international, 2015. **52**(3): p. 243-253.
- [33] Gruzd, A., K. Staves, and A. Wilk, *Connected scholars: Examining the role of social media in research practices of faculty using the UTAUT model*. Computers in Human Behavior, 2012. **28**(6): p. 2340-2350.
- [34] Kaur, A. and D.H. Chahal, *Role of social media in increasing environmental issue awareness*. Researchers World, 2018. **9**(1): p. 19.
- [35] Severo, E.A., J.C.F.d. Guimarães, M.L. Dellarmelin, and R.P. Ribeiro, *The Influence of Social Networks on Environmental Awareness and the Social Responsibility of Generations*. BBR. Brazilian Business Review, 2019. **16**(5): p. 500-518.
- [36] Ballew, M.T., A.M. Omoto, and P.L. Winter, *Using Web 2.0 and social media technologies to foster proenvironmental action*. Sustainability, 2015. **7**(8): p. 10620-10648.
- [37] Lenoir, P., B. Moulahi, J. Azé, S. Bringay, G. Mercier, and F. Carbonnel, *Raising awareness about cervical cancer using Twitter: content analysis of the 2015#SmearForSmear campaign*. Journal of medical Internet research, 2017. **19**(10): p. e344.
- [38] Hutter, K., J. Hautz, S. Dennhardt, and J. Fuller, *The impact of user interactions in social media on brand awareness and purchase intention: the case of MINI on Facebook*. Journal of Product & Brand Management, 2013.
- [39] Khechine, H., S. Lakhal, and P. Ndjambou, *A meta-analysis of the UTAUT model: Eleven years later*. Canadian Journal of Administrative Sciences/Revue Canadienne des Sciences de l'Administration, 2016. **33**(2): p. 138-152.
- [40] Venkatesh, V., M.G. Morris, G.B. Davis, and F.D. Davis, *User acceptance of information technology: Toward a unified view*. MIS quarterly, 2003: p. 425-478.
- [41] Dwivedi, Y.K., N.P. Rana, A. Jeyaraj, M. Clement, and M.D. Williams, *Re-examining the unified theory of acceptance and use of technology (UTAUT): Towards a revised theoretical model*. Information Systems Frontiers, 2019. **21**(3): p. 719-734.
- [42] Fishbein, M., *leek Ajzen (1975)*. Belief, attitude, intention and behavior: An introduction to theory and research: p. 181-202.
- [43] Williams, M.D., N.P. Rana, and Y.K. Dwivedi, *The unified theory of acceptance and use of technology (UTAUT): a literature review*. Journal of enterprise information management, 2015.
- [44] Fu, L., Y. Zhang, and Y. Bai, *Pro-environmental awareness and behaviors on campus: Evidence from Tianjin, China*. EURASIA Journal of Mathematics, Science and Technology Education, 2017. **14**(1): p. 427-445.

# Power Capacity Assessment of Hybrid Diesel-Solar Photovoltaic Microgrid in Tablas Island, Romblon

Junrey Garcia

Romblon State University, Romblon, Philippines  
Email: junrey2026@gmail.com

**Abstract**— The energy profile of Tablas Island has been demanding in the past years due to the emerging commercialization and even industrialization. Power capacity assessment was conducted in order to verify the sufficiency of power for supply in the coming years considering the increasing demand of energy. A forecast for annual power peak demand was considered in this study in comparison to the dependable capacity of the hybrid microgrid. It shows that the power peak demand from 2018 to 2030 is significantly increasing from 7.19MW to 13.02MW. The 8.8Mega-Watt (MW) diesel-fired power plant has dependable capacity of 6.16MW to 7.04MW from its 70% to 80% plant utilization respectively. The 7.5MW peak solar PV power plant has the maximum AC power capacity of 5.77MW. These power plants were the composition of the hybrid microgrid delivering power from 6.80MW to 8.89MW. Based on the forecast data for annual power peak demand towards 2030, it only met the demand of 8.65MW in the year 2021 but this power did not meet the peak demand in the succeeding years. Several methods to augment the power capacity of the hybrid microgrid were suggested in this study considering the mixed application of conventional and the application of more renewable energy sources as power key-players for generation and distribution.

**Index Terms**— Capacity Assessment, Dependable Capacity, Hybrid Microgrid, Solar Photovoltaic

## I. INTRODUCTION

The nation's demand of energy shows a bigger picture of how promising its roadmap towards development. Economic development greatly rely on how much power is used for transportation, communication, facility operation and the like (Ashkar, Samra, Auwerswald, & Holverson, 2017). The energy security roadmap of the Philippines is a combined effort of all energy industry in the exploration of new available energy sources. Both renewable and conventional energy resources are critical roles that will continue to reinforce and mitigate the increasing demand of energy.

Tablas as the largest of the islands that comprise the province of Romblon has a land area of 135,590 hectares for an estimated 43,400 households (Singh, 2019). Tablas Island Electric Cooperative (TIELCO) and National Power Corporation-Small Power Utility's Group (Napocor-SPUG) had been operating in Odiongan Town in Tablas since 1988. In 2014, Napocor-SPUG generates 4.8MW against the island's demand of 5.9MW resulting to frequent power outage to Tielco's franchise areas (Cinco, 2005). In June 28, 2015, Sunwest Water & Electric Company (SUWECO) replaced the role of power generation in the island. The plant has eight units of 1.1MW Cummins modular diesel engine that generates efficient power for Tablas's microgrid. It has the capability to supply power to more than 200,000 residents (The Manila Times, 2015).

The power generation privatization was intended to unravel the worsening power outage in the island. Power outage

records show how demanding the energy profile of Tablas Island, Romblon.

Figure 1 shows the unscheduled power outage of Tielco from year 2013 to 2017 and the highest was recorded in 2015.

Power outage was minimized in 2016 but in 2017, it re-emerged again. Figure 2 shows the power generation outage from year 2013 to 2017 and the highest outage were recorded in 2014 under Napocor-SPUG generation. After privatization, the outage was minimized in 2016. However, power outage re-emerged in 2017 and reached a mean loss of 19.05 MWhr. This shows that even privatization took the role in power generation; outages were not avoided due to the increasing demand of power in the microgrid.

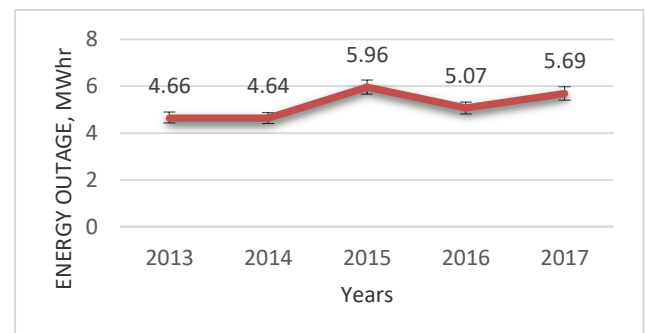

**Figure 1. TIELCO's Unscheduled Power Outages from 2013–2017**

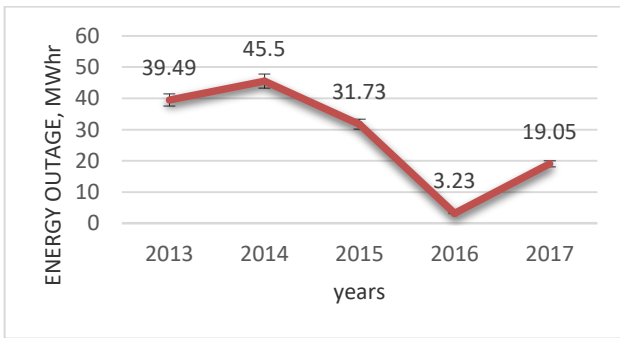

Figure 2. Diesel-Fired Power Plant Outages from 2013–2017

The roadmap towards the year 2030 for the required annual energy supply is significantly inclining which means the demand of power in the coming years will test the limit of the power plant capacity. In Figure 3, the year 2018 consumed about 40,243.16 MWhr of energy and this will be doubled by the year 2030. This expected higher demand of energy in the coming years will necessitate much reliable power supply.

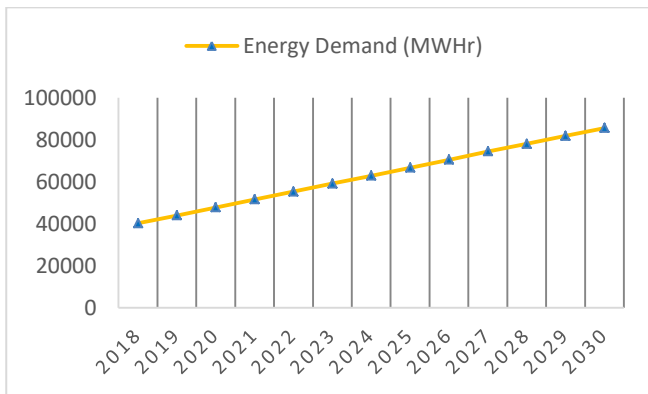

Figure 3: TIELCO's Annual Energy Demand Forecast 2018-2030

The province is looking for sufficient and reliable power supply. Tapping the island's renewable energy resources is one of the options to solve the power outage problem in Tablas. Solar power is one of the most feasible renewable energy resources in the island having enough irradiance of 5.5 kWh per square meter per day (Fajardo, et al., 2014).

On August 21, 2019, a 7.5MW peak solar photovoltaic (PV) power plant was inaugurated in an intention to supply clean energy in addition to the 8.8MW diesel-fired power plant capacity. This is the hybrid diesel-solar PV microgrid which is considered the largest in the Philippines. Despite the existence of the solar PV power plant, the diesel power plant was still operating in its full potential due to the varying and penetrating supply of solar energy. Hence, power interruption occurs especially during seasons of high demand. With this foreseen problem, power capacity assessment was indeed an important thing to conduct in order to verify the sufficiency of power for supply in the coming years considering the increasing demand of energy for Tablas Island.

II. OBJECTIVES

The main objective of the study is to conduct power capacity assessment of hybrid diesel-solar photovoltaic microgrid of Tablas Island, Romblon. Specifically, this study aims to:

1. Forecast annual power peak demand towards year 2030;
2. Determine the dependable AC capacity of the Solar PV power plant at;
  - a. 50% nominal power rating;
  - b. 100% nominal power rating;
  - c. 150% nominal power rating;
  - d. 200% nominal power rating.
3. Determine the power capacity of the hybrid microgrid based on the dependable capacity of both diesel-fired and solar PV power plants;
4. Determine the overall theoretical DC peak power of the solar PV power plant based on degradation rate of the PV module.

III. MATERIALS AND METHODS

A. Materials

Data. Data collected are power outages record, machine count and its current workability, and the solar PV installed capacity. These data are the backbone or the primary supporting information in order to sufficiently conduct the necessary calculation and assessment needed for this study.

B. Methods

Data gathering, preliminary assessment, calculation and analysis, drawing conclusion and recommendation were the steps made in conducting this study.

Data gathering. Energy purchase records for Tablas's grid were collected. The current grid capacity was based on the amount of power generated both by the diesel power plant and the solar power plant facility. Data gathered also included machine count and utilization rate of each, which was conducted during plant visitation and plant personnel interviews. Power outage data on both power plant and distribution facility were also gathered. The record covers monthly outage rate for the year 2013-2017. Knowing all these data, the assessment for the current grid capacity was made for the next stage.

Preliminary assessment. Gathered data were then evaluated. A forecast of the power demand towards the year 2030 was made. By evaluating the current grid capacity and the power outage record, information on how much power supply will suffice the demand was determined.

Calculation and analysis. The variables herein were all collected from the mathematical simulation using the analysis of regression.



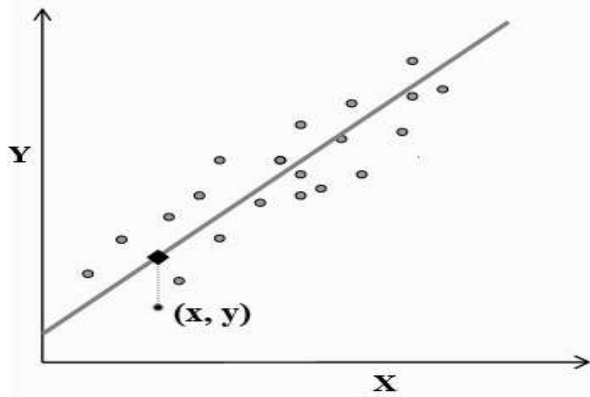

**Figure 4. The Ordinary Least Square Method**

This method minimizes the difference between the observed and estimated value. Requires that the sum of the squares of the errors for the best fit function be at the minimum as calculated using this equation;

$$Y_i = a + bX_{1i} + \varepsilon_i \tag{1}$$

$$\varepsilon_t = Y_t - \hat{Y}_t \tag{2}$$

In order to find the best fit, errors are squared then minimized with respects to the coefficients a and b which can be solved using this equation;

$$b = \frac{n \sum X_i Y_i - n \sum X_i \sum Y_i}{n \sum X_i^2 - (\sum X_i)^2} \tag{3}$$

$$a = \frac{\sum Y_i - b \sum X_i}{n} \tag{4}$$

The annual power peak demand forecast was determined using the equation derived from load distribution forecasting.

$$Demand_{Peak} = \frac{Demand_{Average}}{Load\ Factor} \tag{5}$$

$$Demand_{Average} = \frac{Energy\ (kW - hr/year)}{Time\ (8760\ hrs/year)} \tag{6}$$

This is the baseline data for the capacity evaluation and expansion estimation. The dependable capacity of the 8.8MW diesel-fired power plant and the 7.5MWp solar PV power plant are needed to be analyzed whether the generated power of this hybrid facility met the power demand given by the forecast data.

To get the dependable capacity of the diesel power plant, the installed capacity of the plant must be multiplied to the machine utilization factor ( $U_f$ ). Machine utilization factor is the operational capacity of the diesel generators in percentage to maintain its reliable and efficient operation. Hence, we use the equation to get the dependable capacity of the diesel power plant:

$$MW_{dependable} = MW_{installed} \times U_f \tag{7}$$

For the solar PV dependable capacity determination, an equation was used to calculate the amount of AC power for distribution relating to the peak DC installed capacity and the inverter’s performance factor. It was called inverter loading ratio (ILR) and was calculated as:

$$AC\ Output\ (W) = \frac{Installed\ Capacity\ (Wp)}{ILR} \tag{8}$$

A conservative ILR of 1.3 is used in this calculation. This is also based on the variable penetration of solar energy on the PV array.

Considering the mean and median degradation rating of the PV modules of any type at 0.8% and 0.5% annually, we use geometric progression to determine the maximum DC peak capacity of the solar PV until year 2030.

$$a_n = a_1 r^{n-1} \tag{9}$$

Where:  $a_n$  is the plant capacity in the year 2030;

$a_1$  is the installed capacity;

$r$  is the common ratio;

$n$  is the nth year of the solar PV power plant.

Also, the uncertain conditions which affect the performance of the PV modules, percent nominal power rating was included in the calculation such as when the nominal power rating was at 50%, 100%, 150% or 200% respectively.

*Drawing conclusion and recommendation.* Based on the conducted calculation and analysis, the hybrid diesel-solar PV microgrid capacity can now be concluded whether its generated power met the pre-determined demand until year 2030. It offers possible power security scheme if the supply does not satisfy the demand criterion of the island. It exhibits methods from conventional to non-conventional schemes in order to meet the ever-increasing demand of the island. Moreover, it demonstrates environmental awareness on CO2 emission reduction because of the renewable energy power generation application as one of the power key-player for distribution.

#### IV. RESULTS AND DISCUSSION

##### Results

*Power demand forecast.* Based on the forecast data, Tablas Island pushes its way towards rapid development as its power demand increases annually as shown in figure 5.

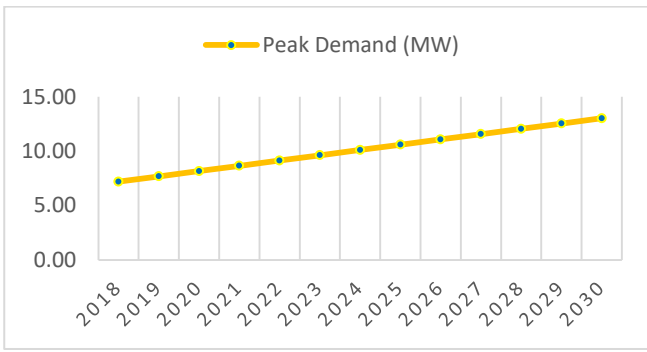

Figure 5. Yearly Peak Demand Forecast 2018-2030

*Microgrid dependable capacity.* The dependable capacity of the hybrid diesel-solar PV microgrid considering percent utilization of the diesel power plant, and nominal power rating are shown below.

Table 1: Dependable Capacity Matrix of 7.5MWp Solar PV Power Plant

Nominal Power (%)	Multiplier	Megawatt Peak (DC)	MW Generated (AC)
50	0.1105	0.829	0.638
100	0.2011	1.508	1.160
150	0.2779	2.084	1.603
200	0.3211	2.408	1.853

Table 2: Power Capacity of the Hybrid Diesel – Solar PV Microgrid at 70% Utilization Rate of the Diesel Power Plant

Rated Nominal Power (%)	Total Power Generated (MW)
50	6.798
100	7.320
150	7.763
200	8.013

Table 3: Power Capacity of the Hybrid Diesel – Solar PV Microgrid at 80% Utilization Rate of the Diesel Power Plant

Rated Nominal Power (%)	Total Power Generated (MW)
50	7.678
100	8.200
150	8.643
200	8.893

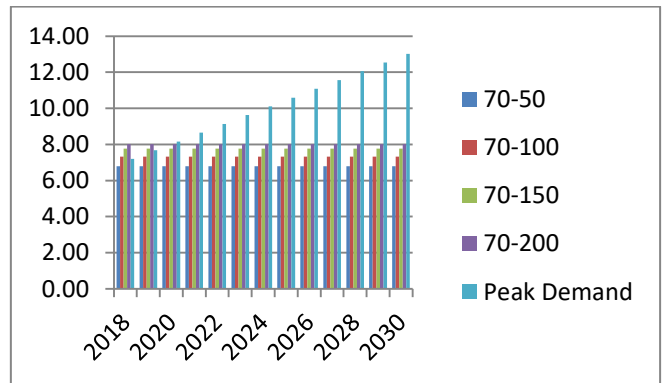

Figure 6: Power Capacity of the Hybrid Diesel – Solar PV Microgrid at 70% Utilization Rate of the Diesel Power Plant

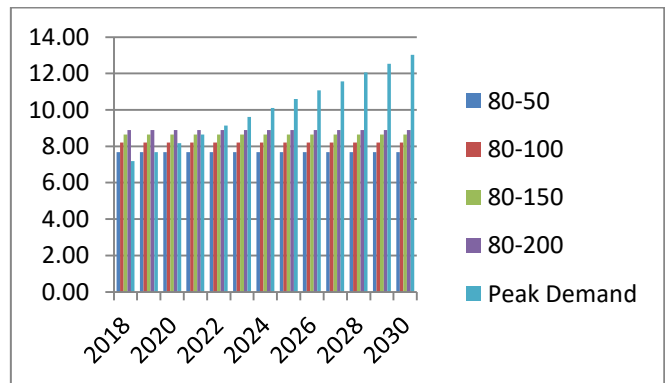

Figure 7: Power Capacity of the Hybrid Diesel – Solar PV Microgrid at 80% Utilization Rate of the Diesel Power Plant

*Peak capacity degradation.* The installed peak capacity of the solar PV drops within the rate of 0.5% and 0.8% annually. The graph below shows significant declination of installed DC peak power of the 7.5MWp solar PV power plant.

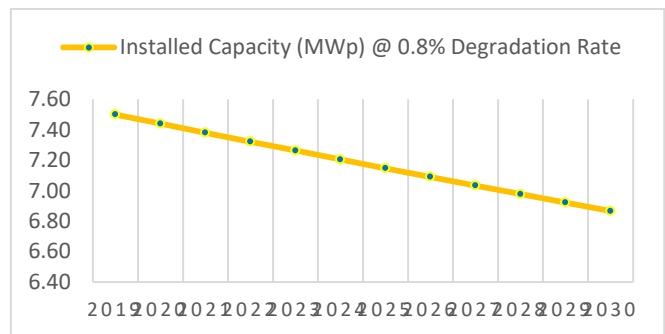

Figure 8: Solar PV capacity degradation 2019-2030 at 0.8% degradation rate



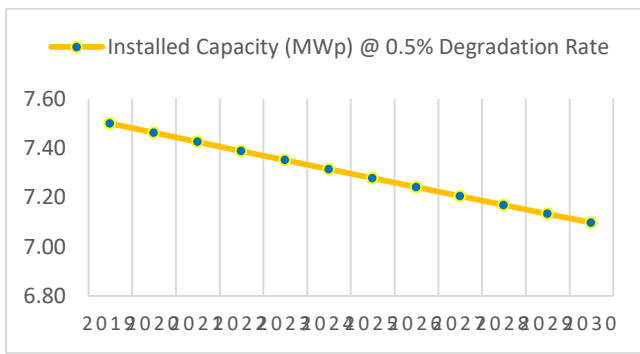

Figure 9: Solar PV capacity degradation 2019-2030 at 0.5% degradation rate

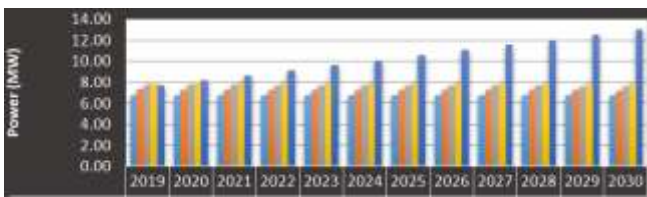

Figure 10: Power Capacity of the Hybrid Diesel-Solar PV Microgrid at 70% Diesel Plant Utilization and 0.8% PV Module Degradation Rate

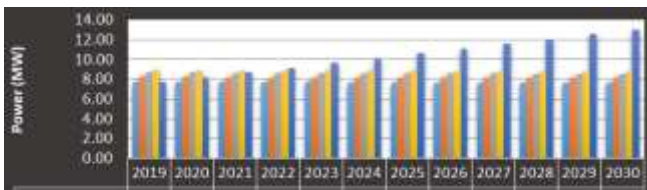

Figure 11: Power Capacity of the Hybrid Diesel-Solar PV Microgrid at 80% Diesel Plant Utilization and 0.8% PV Module Degradation Rate

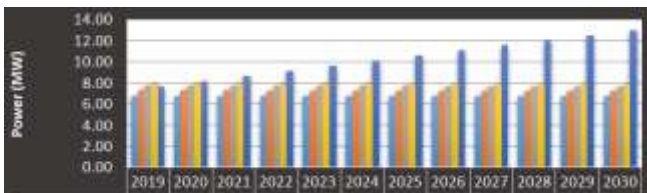

Figure 12: Power Capacity of the Hybrid Diesel-Solar PV Microgrid at 70% Diesel Plant Utilization and 0.5% PV Module Degradation Rate

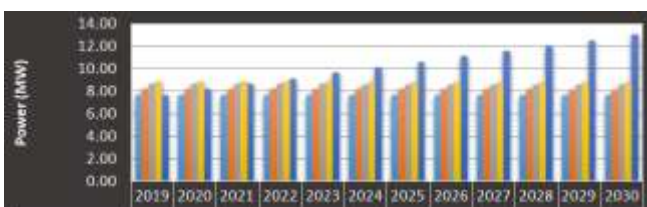

Figure 13: Power Capacity of the Hybrid Diesel-Solar PV Microgrid at 80% Diesel Plant Utilization and 0.5% PV Module Degradation Rate

**Discussion**

Figure 5 shows that there is a steady rise in demand on the roadmap towards the year 2030. Significantly, it shows that there is already power insufficiency in the year 2022 given

that the operational plant utilization of the diesel-fired power plant remains at 80% maximum.

Given the installed capacity of diesel power plant at 8.8MW, the dependable capacity at 70% to 80% plant utilization was 6.16MW to 7.04MW. In the case of 7.5MW peak solar PV power plant, the theoretical maximum AC generated is 5.77MW considering the inverter loading ratio (ILR) of 1.3. While the theoretical AC generated of solar PV power plant considering the degradation rate of solar modules at 0.5% and 0.8% was 5.46MW and 5.28MW respectively towards the year 2030. The amount of dependable power capacity of solar PV power plant ranges between 0.638MW at 50% nominal power rating to 1.853MW at 200% nominal power rating as shown in Table 1. The range of dependable capacity of solar PV power plant depends upon any certain condition during its operation. It involves cloud shading, changes in ambient temperature and the varying solar irradiance at a certain time of the day. The power generated by the solar PV power plant is mixed with the output generated power of the diesel power plant, resulting to hybrid diesel-solar PV power generation.

At 70% plant utilization of the diesel power plant, when combined with the varying output of solar PV power plant, the total generated power ranges from 6.798MW to 8.013MW as shown in Table 2 while at 80% plant utilization, when combined with the varying output of solar PV power plant, the total generated power ranges from 7.678MW to 8.893MW as shown in Table 3. This shows that the allowable plant capacity of the hybrid microgrid ranges within 6.798MW to 8.893MW AC power.

Based on Figure 6, when the utilization rate of 8.8MW diesel power plant is 70% and the nominal power rating of solar PV power plant reaches 200% maximum, the total generated power is 8.013MW. It met the demand of 7.679MW for the year 2019. But this power did not meet the peak demand of 8.164MW for the year 2020. When the utilization rate of the diesel-fired power plant was increased to 80% and the nominal power rating of solar PV power plant reaches 200% maximum, the total generated power is 8.893MW as shown in Figure 7. It met the demand of 8.65MW for the year 2021. But this power did not meet the peak demand of 9.136MW for the year 2022 and onwards.

In Figure 8 and 9, the amount of DC peak power (installed capacity) drops from 7.10MWp to 6.87MWp towards the year 2030 due to the annual degradation rate of 0.5% to 0.8% respectively. Although the rate of degradation is too small to consider, it still contributed to the overall grid performance of the hybrid microgrid considering the demand of power is increasing.

Figure 10 shows the power capacity mix of the hybrid microgrid having 70% diesel-fired plant utilization rate, 50% - 200% solar PV nominal power rating, and 0.8% degradation rate. It shows that the capacity of the grid at varying nominal power rating was decreasing annually while the demand is significantly increasing. Same through

with the other power mix as shown in Figure 11, 12 and 13 which means that the microgrid needs more reliable power generation scheme to meet the demand in the upcoming years.

## V. CONCLUSION AND RECOMMENDATION

### Conclusion

Based on results of the study, the following conclusions are made:

1. Power peak demand of Tablas Island is significantly inclining from 7.19MW to 13.02MW from 2018 to 2030 based on the annual peak demand forecast.
2. The dependable AC capacity of the 7.5MWp solar PV power plant was determined to be:
  - a. 0.638MW at 50% nominal power rating;
  - b. 1.160MW at 100% nominal power rating;
  - c. 1.603MW at 150% nominal power rating;
  - d. 1.853MW at 200% nominal power rating.
3. The power capacity of the hybrid microgrid was determined to be:
  - a. 6.80MW at 70% utilization rate of diesel-fired power plant and 50% nominal power rating of solar PV power plant;
  - b. 7.32MW at 70% utilization rate of diesel-fired power plant and 100% nominal power rating of solar PV power plant;
  - c. 7.76MW at 70% utilization rate of diesel-fired power plant and 150% nominal power rating of solar PV power plant;
  - d. 8.01MW at 70% utilization rate of diesel-fired power plant and 200% nominal power rating of solar PV power plant;
  - e. 7.68MW at 80% utilization rate of diesel-fired power plant and 50% nominal power rating of solar PV power plant;
  - f. 8.20MW at 80% utilization rate of diesel-fired power plant and 100% nominal power rating of solar PV power plant;
  - g. 8.64MW at 80% utilization rate of diesel-fired power plant and 150% nominal power rating of solar PV power plant;
  - h. 8.89MW at 80% utilization rate of diesel-fired power plant and 200% nominal power rating of solar PV power plant.
4. The overall theoretical DC peak power of the solar PV power plant was:
  - a. 7.46MWp at 0.5% degradation rate and 7.44MWp at 0.8% degradation rate by the year 2020;

- b. 7.43MWp at 0.5% degradation rate and 7.38MWp at 0.8% degradation rate by the year 2021;
- c. 7.39MWp at 0.5% degradation rate and 7.32MWp at 0.8% degradation rate by the year 2022;
- d. 7.35MWp at 0.5% degradation rate and 7.26MWp at 0.8% degradation rate by the year 2023;
- e. 7.31MWp at 0.5% degradation rate and 7.20MWp at 0.8% degradation rate by the year 2024;
- f. 7.28MWp at 0.5% degradation rate and 7.15MWp at 0.8% degradation rate by the year 2025;
- g. 7.24MWp at 0.5% degradation rate and 7.09MWp at 0.8% degradation rate by the year 2026;
- h. 7.21MWp at 0.5% degradation rate and 7.03MWp at 0.8% degradation rate by the year 2027;
- i. 7.17MWp at 0.5% degradation rate and 6.98MWp at 0.8% degradation rate by the year 2028;
- j. 7.13MWp at 0.5% degradation rate and 6.92MWp at 0.8% degradation rate by the year 2029;
- k. 7.10MWp at 0.5% degradation rate and 6.87MWp at 0.8% degradation rate by the year 2030.

The power capacity of the hybrid diesel-solar PV microgrid will suffice the power demand of Tablas Island until 2021 only based on forecast data considering the attainment of maximum 80% diesel-fired power plant utilization. Forecast data is just an estimate of power demand's varying movement. However, it is important for us to be well informed on the current situation to act ahead of time in order to solve these foreseen problems in the future.

### Recommendation

There are several methods to augment the power capacity of the hybrid diesel-solar PV microgrid in Tablas Island. One of which is by increasing the utilization rate of the 8.8MW diesel power plant from 90% to 100% resulting to 9.773MW to 10.653MW which will suffice the demand until 2025 only based on forecast data. This will result to a more operational activity of the power generators, reducing its resting pace, and machine life expectancy will be shortened.

Another method is by adding five more 1.1MW generator sets in the microgrid resulting to a total of 13.293MW power capacity of the hybrid diesel-solar PV microgrid able to meet the peak demand of 13.023MW in the year 2030. But it gives huge amount of carbon emission in the atmosphere by 87,158 tons of carbon dioxide and 8.57 million gallons of diesel consumption in 2030.

Another method is by expanding the solar PV power plant by adding 17MWp solar PV expansion. It was almost 2.3 times the size of the existing solar PV power plant. In this rate, the diesel power plant operates at 80% plant utilization with the assumption of 200% nominal power rating dependable capacity of the whole solar PV power plant.

When combined, the total AC power generated is 13.09MW able to suffice the peak demand in the year 2030 as projected by the forecast data. The amount of CO<sub>2</sub> emission reduction was 40,500 tons and saved 3.98 million gallons of diesel fuel.

In consideration to the power capacity augmentation, it is highly recommended to conduct power capacity optimization for the hybrid power mix in Tablas Island, Romblon. It is for the purpose of finding suitable amount of conventional and renewable energy resources application as power key-players for generation and distribution.

## REFERENCES

- [1] Anayochukwu, A., & Nnene, E. (2013). Measuring the environmental impact of power generation at GSM base station sites. *Electronic Journal of Energy and Environment*, (pp.1-10).
- [2] Ashkar, A., Samra, K., Auwerswald, P., & Holverson, K. (2017). Harnessing the power of energy to transform the lives of 10 million people. *2018 Hult Prize Challenge*, (pp. 1-44).
- [3] Bajpai, P., Dash, V., & Kishore, N. (2010). Bi-annual sun tracking for solar PV module support structure: Study and implementation. *16<sup>th</sup> National Power Systems Conference*, (pp.56-61)
- [4] Fajardo, J., Ruales, M., Wilhelm, B., Meller, H., Larona, F., Kuvarakul, T., et al. (2014). *Renewable Energy Guidelines on Large Solar Photovoltaic Project Development in the Philippines*. Manila: Deutsche Gesellschaft Fur Internationale Zusammenarbeit (GIZ) GmbH.
- [5] Jordan, D., & Kurtz, S. (2012). Photovoltaic Degradation Rates - An Analytical Review. *NREL/ JA-5200-51664*, 1-32.
- [6] Joyce, K. (2012). Optimizing PV Plant Design to Achieve a Low Levelized Cost of Energy. *Black & Veatch Holding*, pp. 1-8.
- [7] Lim, V., Leong, C., Sopian, K., & Zaidi, S. (2016). Pulsed Solar Panel Light Current-Voltage Characterization Based on Zener Diode. *2016 IEEE Conference on Systems, Process and Control (ICSPC 2016)* (pp. 177-180). Melaka, Malaysia: IEEE.
- [8] Masters, G. (2004). *Renewable and Efficient Electric Power Systems*. Hoboken, New Jersey: John Wiley & Sons Incorporation.
- [9] Naksrisuk, C., & Audomvongseree, K. (2013, August). Dependable Capacity Evaluation of Wind Power and Solar Power Generation Systems. *ECTI Transactions on Electrical Eng., Electronics, and Communications Vol.11, No.2*, pp. 58-66.
- [10] Power Systems Engineering Committee of the IEEE Industry Applications Society. (1991). *IEEE Recommended Practice for Electric Power Systems in Commercial Buildings*. New York: Institute of Electrical and Electronics Engineers, Inc.
- [11] Power Systems Reliability Subcommittee of the Power Systems Engineering Committee of the IEEE Industry Applications Society. (2007). *IEEE Recommended Practice for the Design of Reliable Industrial and Commercial Power Systems*. Nanyang: Institute of Electrical and Electronics Engineers, Inc.
- [12] Sark, W., Reich, N., Muller, B., & Armbruster, A. (2012). Review of PV Performance Ratio Development. *World Renewable Energy Forum*, (pp. 1-6). Denver, Colorado.
- [13] Sassine, E. (2016). Optimal Solar Panels Positioning for Beirut. *2016 7th International Renewable Energy Congress* (pp. 1-10). Beirut, Lebanon: 10.1109/IREC.2016.7478940.
- [14] Singh, M. (2016). Efficient Autonomous Solar Energy Harvesting System Utilizing Dynamic Offset Feed Mirrored Parabolic Dish Integrated Solar Panel. *IEEE WiSPNET 2016* (pp. 1825-1829). India: IEEE.
- [15] Singh, M., Singh, J., Garg, A., Sidhu, E., Singh, V., & Nag, A. (2016). Efficient Autonomous Solar Energy Harvesting System Utilizing Dynamic Offset Feed Mirrored Parabolic Dish Integrated Solar Panel. *IEEE WiSPNET 2016 conference*, (pp. 1825-1829). Patiala, India.
- [16] Wittmer, B., Mermoud, A., & Schott, T. (2015). Analysis of PV Grid Installations Performance, Comparing Measured Data to Simulation Results to Identify Problems in Operation and Monitoring. *European Photovoltaic Solar Energy Conference*, (pp. 1-6). Hamburg, Germany.



# The Determinants of the Innovation-Friendly Environment in Europe in the Period 2000-2019

<sup>[1]</sup> Alberto Costantiello, <sup>[2]</sup> Lucio Laureti, <sup>[3]</sup> Angelo Legrande

<sup>[1]</sup> Ph.D., Professor of Economics and International Economics at LUM University-Giuseppe Degennaro, Università LUM Giuseppe Degennaro, Casamassima (BA), Italy

<sup>[2]</sup> Professor of Economics at LUM University-Giuseppe Degennaro, Università LUM Giuseppe Degennaro, Casamassima (BA), Italy

<sup>[3]</sup> Ph.D., Scholar in the Discipline of Economics at LUM University-Giuseppe Degennaro, Università LUM Giuseppe Degennaro, Casamassima (BA), Italy

Email: <sup>[1]</sup> costantiello@lum.it, <sup>[2]</sup> laureti@lum.it, <sup>[3]</sup> angelo.economics@gmail.com

**Abstract**— In this article we investigate the determinants of the innovation-friendly environment in Europe in the period 2000-2019. We use data from the European Innovation Scoreboard of the European Commission for 36 countries. Data are analyzed using dynamic panel data at 1 stage, panel data with fixed effects, panel data with random effects, pooled OLS, and WLS. Results shows that the “Innovation-Friendly Environment” is positively associated to “Basic-school entrepreneurial education and training”, “Government procurement of advanced technology products”, “Employment share Manufacturing”, “Finance and support”, “Human resources”.

JEL Code: C33, O3, O30, O31, O43

## I. INTRODUCTION

In this article we analyze the determinants of the innovation-friendly environment in Europe in the period 2000-2019. We use data from the European Innovation Scoreboard. The main idea of the article is that innovation is that there are socio-cultural, political, and institutional factors that can shape the degree of innovation at a country level. Innovation is an essential tool for economic growth. The role of innovation has been explicitly recognized in Schumpeterian economics [1] and in the endogenous growth theory [2]. Even Robert Solow’s theory of economic growth recognizes the role of technological change, innovation and Research and Development in increasing the efficiency of human capital [3].

But the innovation-friendly environment is not only determined by economic and financial variables. Also cultural and socio-psychological factors have a role in creating the condition for an innovation-friendly environment. In this sense we refer to the theory of the Dutch sociologist and anthropologist Geert Hofstede that has developed a model based on six variables to evaluate the impact of cultural factor on economic and corporation performance at a country level. We report a literature review that is centered on the ability to use Hofstede’s index to evaluate the ability of economic organizations and national productive systems to promote innovation.

Finally, we run an econometric analysis to evaluate the determinants of the innovation-friendly environment in Europe. Results show that the innovation-friendly environment is positively associated to “Basic-school entrepreneurial education and training”, “Government procurement of advanced technology products”,

“Employment share Manufacturing”, “Finance and support”, “Human resources”.

The second paragraph shows a literature review, the third paragraph presents the model and the econometric results, the fourth paragraph contains the conclusion, the fifth paragraph shows the bibliographical references, the sixth paragraph is an appendix with a collection of data and metric models.

## II. LITERATURE REVIEW

**The innovation-friendly culture in the theory of Hofstede.** [4] afford the question of the social and cultural determinants of innovation as a tool for economic development. The authors specifically focus their attention of the relevance of culture in determining an innovation-friendly environment and in improving the ability to promote innovation capacity in a society. The authors use the Hofstede Index to evaluate the relationship between culture and innovation. The Hofstede Index as been realized by Geert Hofstede (1928,2020) that was a pioneer in social research. The Hofstede Index, in its second and more complete version, contains 6 dimensions that can be used to classify cultural behaviors that are:

- *Power distance index*: that is a measure of inequality of the distribution of power among a certain society;
- *Individualism vs collectivism*: the degree of integration of individual in groups at a societal level;
- *Uncertainty avoidance*: that is the tolerance for alternative thinking and non-conventional visions;
- *Masculinity vs femininity*: masculinity is the preference for heroism and a culture of achievement in a certain

society, while femininity is based on a preference on cooperation, modesty and tolerance for weaknesses.

- *Long term orientation vs short term orientation:* that explain the relationship that a certain population has with its tradition in respect to the future;
- *Indulgence vs restraint:* the degree of freedom in pursuing individual desires.

The authors consider innovation as a crucial competence to achieve economic growth. And they question if the ability to orient an certain society towards a cultural environment that is innovation-friendly can be learned. And they answer to this question positively, considering that if creativity and the culture of innovation are skills than these skills can be learned and translated in the institutional and political framework of a certain country. The authors specifically found that there is a positive relationship between innovation friendly culture and:

- *Higher individualism:* countries in which individualism is more accepted as a social behavior show higher degree of innovation. The culture of individualism is positively associated to innovation and technological development. If politicians are interested in building a social behavior that is more oriented to innovation, they should promote individualism.
- *Willingness to take risks:* a more risk-oriented behavior is associated to countries with higher levels of innovation. Innovation requires to take risks due to the uncertainty of the outcomes that relate to the technological change. If politicians are interested in creating a society based on innovation than they should introduce incentives that help individuals to take more risks.
- *Readiness to accept change:* countries in which people is more able to sustain and participate in the technological, institutional, and societal change are more able to develop a culture that is innovation friendly.
- *Long term orientation:* societies and cultures that are oriented to long term period have more probabilities to produce a culture able to promote innovation. Since innovation requires investments, institutions, educations, enrichment of human capital, it is necessary to take a long term to evaluate the efficacy of the political implications of innovation friendly environment.
- *Low power distance:* countries in which the population is less oriented to accept a non-egalitarian distribution of the power are also more able to develop a deeper innovation friendly culture.
- *Weak uncertainty avoidance:* Innovation-friendly cultures are more able to accept diversity of theories, point of views and ideas.

- *Openness to new information:* innovation friendly cultures are open to the acquisition of new information i.e., to accept the process of technological change and the scientific progress as an essential part of the development of the society.
- *Frequent travel:* countries in which the population travel frequently show a more innovation-friendly culture.
- *Positive attitude towards science:* countries that have a positive attitude toward science have also greater probabilities to develop an innovation-friendly culture.
- *Value of education to society:* countries that invest more in education and instruction have also greater probabilities to develop an innovation-friendly culture.
- *Religion:* countries that have a society more oriented to religious values have also greater opportunities to develop an innovation-friendly culture.

[4] show how culture can have an essential role in shaping the innovation-friendly environment using the Hofstede Index.

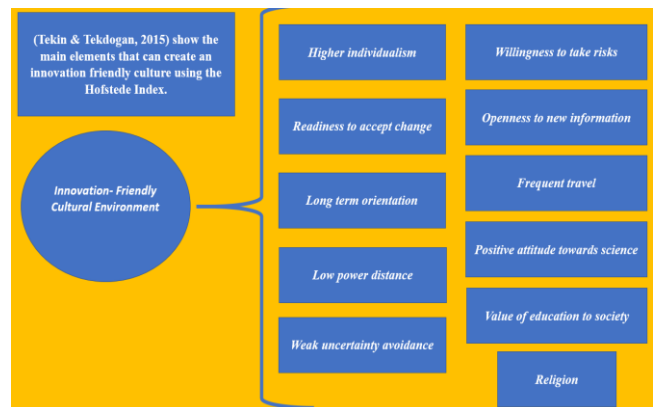

Figure 1. (Tekin & Tekdogan, 2015) show the determinants of the innovation-friendly culture using the Hofstede Index.

[5] analyze the relationship between national culture and national preferences for innovation with a sample of 1228 individuals in 30 countries. The authors find that:

- if a society is uncertainty avoiding then it recognizes a greater relevance to norms, rules, and procedure in promoting innovation. Uncertainty avoiding operates as an external intangible condition that reduce the ability of innovators to promote innovation, freely.
- if a country is characterized by power distance then there is an increasing probability that innovators try to have support from authorities rather than creating autonomously the condition to promote innovation. Power distance inhibits the freedom of innovators through implicit norms and explicit hierarchies.
- If a society is oriented to collectivism, then there are greater probabilities to promote inter-functional

innovation and to promote cooperation among innovators among different sectors.

There is a positive relationship between cultural values and preferences for innovation at a country level. The collectivist orientation of a society boosts cross-sectors innovation through cooperation among institutions and organizations. If a society accept uncertainty then innovators challenges norms, values, and rules. If a society sustain a non-egalitarian distribution of power, then innovators try to obtain support from authorities in the reduction of their individual freedom to innovate.

[6] consider the positive relationship between the number of per capita of trademarks and the presence of individualism, uncertainty avoidance and power distance at a country level. The authors perform multi-linear regression to estimate the impact of Hofstede's measures of cultural environment and the innovation as it has been defined in the Global Innovation Index. The results show that:

- There is a negative relationship between the Global Innovation Index score and power distance i.e., the greater is the inequality of distribution of power in a certain society the lower is the degree of innovation;
- There is a positive relationship between individualism and the Global Innovation Index scores i.e., the greater is the orientation of a society toward individualism the greater is the ability of society to innovation.

If politicians are interested in promoting an innovation friendly environment in the sense of culture, then they should try to reduce the degree of power distance. In countries with high power distance workers are not autonomous and they need to be guided in the process of value creation in the reduction of the ability to innovate. At the contrary in countries with a low level of power distance there is an active participation of workers in the creation of innovation. Power distance is cultural determinants that can have a relevant impact on the reduction or empowerment of employees in the sense of innovation. If power distance is low then employees have greater incentives to communicates with hierarchies to promote new ideas, new products and services creating the condition for a more innovation friendly environment.

Similarly, if a society is more oriented to individualism than can promote a deeper orientation towards meritocracy, independence, autonomy, and freedom. The authors suggest that on one side, in collectivists society confrontation is avoided to preserve harmony, while on the other side individualistic societies are more oriented to confrontation and through this way it is possible to develop more ideas and, in the end, to produce innovation.

[7] afford the question of the presence of different levels of innovation among different countries. Specifically, the author analyzes data from the European Innovation Scoreboard. [7] considers the relationship between innovation and culture at a country level in European

nations in the light of the Hofstede's theory. The author finds that nations with similar cultural characteristics have also similar results in term of innovation. Specifically, in the most innovative countries have low power distance, a higher degree of acceptance for uncertainty and an deeper recognition of the role woman in the society. On the contrary less innovative countries have higher degree of power distance, a deeper uncertainty avoidance and tends to be prefer a masculine culture over a feminine culture.

[8] analyze the relationship between uncertainty and innovation in a dataset of 4405 individuals for forty-three organizations in sixty-eight different countries. The author finds that countries that accept uncertainty show higher degree of innovation while countries that avoid innovation are oriented to a lower degree of innovation. The results show that uncertainty accepting societies can promote innovation. The author suggests that the positive relationship between innovation and uncertainty avoiding society can be used to solve the question of the location of plants for multinational corporations. If a manager of a multinational corporation needs to find the best location in the sense of innovation, then the manager can choose based on the uncertainty-acceptance criterion on a national and regional level. In this sense uncertainty acceptance society are more able to create an innovation-friendly environment either for SMEs either for big corporations. Uncertainty acceptance society can also improve the degree of Foreign Direct Investment-FDI.

[9] afford the question of the relationship between innovation and enterprise in small and medium enterprise-SMEs in Thailand based on Hofstede's theory. The authors find that in Thailand there are traditional cultural values different from Hofstede's variables that can have an impact on the level of innovation. But the participation in an international market can crate the conditions for a change in values among the people increasing the orientation of Thailand culture towards innovation. The authors find also that Thai SMEs are more able to apply incremental innovation rather than radical innovation. Thai SMEs shows inefficiencies in implementing high tech innovation at the frontier of the Research and Development. The low efficiency of Thai SMEs can be explained considering the absence of the Hofstede's variables except for the long run perspective. The contribution of [9] is relevant for the fact that suggest considering the role of regional and local factors in shaping the innovation-friendly environment, especially for SMEs.

[10] suggest to investigate the relationship between cultural environment and the product innovation process at a firm level. More innovative cultures in the sense of product development are based on teamworking and risk-taking. But authors suggest that the creation of best practices based on the theoretical and empirical relationship between cultural environment and product innovation is a challenge for economic organizations. Innovation requires a change in the culture of an organization. The passage between old procedures and narrations to new ideas and procedures is a



challenge that many firms and organization can easily loose without the appropriate cultural background oriented to innovation and technological change. The authors suggest that to analyze the ability of a firm to accept innovation it is necessary to consider tacit beliefs, systems of values, stories, rituals, artifacts.

[11] analyzes the relationships among culture, creativity, and innovation. The authors consider the differences in the conceptualization of creativity among countries and the social determinants of creativity and innovation. [11] also afford the question of the relationship among different types of personalities, cognitive styles, creativity and innovation. The authors find the sequent results:

- Culture has an impact on creativity and innovation even if this relationship cannot be universalized;
- Data do not consent to make definitive statements on the presence of differences among countries in personalities with respect to creativity;
- Creativity and innovation cannot be explained only on the basis of cultural variables without considering other factors that have an impact in shaping the innovation-friendly environment;
- The relationship between culture and innovation does not operate directly but through non-linearity.

The creation of an innovation-friendly environment certainly can be created recognizing the role of cultural determinants, but these cultural determinants are only a part of the complex socio-economic and psychological factors that have a role in orienting a countries towards innovation.

[12] afford the question of the relationship between cultural variables in the sense of Hofstede's theory and innovation measured through the number of patent application in Europe. The authors use data from European Social Survey. Countries that have the greater number of patents are characterized by the presence of low degree of power distance, uncertainty avoidance, family-related collectivism, and masculinity. The lower the degree of these variables the higher the patenting intensity. But the authors suggest that culture alone is not able to guarantee an high number of patents and that in this sense also institutional, economics and political frameworks have a role in orienting a societies towards innovation.

[13] consider the role of innovation and creative ideas for companies and countries. The increasing degree of competitiveness due to globalization has increased the necessity of economic organization to boost innovation to gain efficiency and improving market share. The process of innovation can be better understood considering the role of culture on a country level. Culture has a relevant impact in determining the level of creativity and innovation among countries. The authors in particular use the Global Innovation Index in connection with the Hofstede's theory to investigate the relationship between innovation and culture at a county level. The authors find that more

innovative countries are characterized by the presence of a culture based on individualism, low masculinity, pragmatism and indulgence.

[14] considers the role of creativity and innovation in shaping economic organizations and individual performance at work. The authors suggest three main propositions in their analysis:

- There exist preliminary phases in respect to innovation and creativity at least at a psychological level, that have not been adequately recognized;
- Innovation and creativity can be better understood also considering the role of some concept imported from psychology such as personal initiative and voice behavior;
- Leadership preferences, motivations and cultural differences among values can have a role in the understanding of creative and innovation among countries.

The main contribution of the authors consists in the creation of a nexus between psycho-social determinants at a country level and the creation of an innovation-friendly environment.

[15] analyze literature relative to the impact of culture on innovation. The authors consider a set of peer-reviewed article foe 37 years in the period 1980-2017. The results show the presence of two cluster of articles in studying the relationship among innovation, organizational culture, and national culture. [15] show the presence of a varieties of cultural factors that can promote or to restrict the role of innovation. The complex relationship between innovation and culture let the authors conclude that exist an idiosyncratic nexus between those variables. But the authors realize only a literature review and omit the role of empirical studies in shaping the relationship between innovation and culture. The presence of a nexus between innovation and culture can be useful for manager, that can implement in their organizations more innovation-friendly culture.

[16] afford the question of the innovation-performance in small and medium enterprises. The authors concentrate their attention on resource-scarce SMEs, to investigate if this kind of firm has some economic or financial benefit from innovation. The orientation towards innovation and the innovation activities can create value for SMEs. But innovation is not free for SMEs due to the presence of costs i.e., continuous investments, risks, and uncertainty. But even considering these costs there are relevant benefits for SMEs in investing in innovation such as customer loyalty, price premiums, innovative products, and competitive gains in market share. The authors show that innovation-performance in SMEs depends on the sequent elements: age of the firm, the type of innovation, cultural context.

[17] analyze the relationship among individuals, cultural factors, and innovation. The authors measure on one side

individual factors as based on opinion leaders and on the other side cultural factors are synthesized by avoidance and individualism. The results show that organizations that can promote either inventors either promoters of innovation can be considered as champions of innovation. On the other side, there are cultural factors that can sustain the effort of corporations and economic organizations to promote innovation i.e., individualism and uncertainty.

[18] analyze the relationship between innovation and leadership. Organizational learning has a relevant role in creating the conditions for innovation. The authors find some elements that can promote innovation and firm-level that are: leadership style, individual feature, organizational learning. [18] use a dataset of 408 large firms. The results show that:

- Organizational learning has an impact on innovation that is stronger than CEO leadership;
- CEO leadership has a relevant influence on organizational learning and innovation;
- Innovation can promote firm-performance;
- Organization learning can generate deeper levels of innovation.

The relationship among organizational learning, leadership, innovation, and firm performance are relevant to create the conditions for the establishment of an innovation-friendly environment.

[19] analyze the relevance of innovation as a tool for management. Managers that intend orient their organization towards innovation need to promote a complex set of organizational characteristics that are: flexibility, empowerment, control, and efficiency. Organizational culture is essential to promote innovation among corporations and SMEs. But the rationalization of the organizational culture remains a difficult task either for sociologists and social psychologists. The authors suggest that to implement high tech solution in the organizational structure of corporations is necessary to create a culture of the innovation and value added.

[20] analyze the role of individualism and collectivism in creating the condition for an innovation-friendly environment. The authors find that innovation growths in the case of a moderate relationship between the individualist and the collectivist orientation of the society while it declines either in connection with extreme individualism either as a consequence of deeper collectivism.

[21] analyze the effect of transformational leadership on creativity and innovation either at an individual level either in an organizational perspective. The authors collect data from 163 R&D workers of 43 micro and SMEs Turkish ICT companies. Creativity and innovation growth with the increase of transformational leadership either at a individual level either in an organizational perspective. Employees can

improve their creativity in the case of transformational leadership as a consequence of empowerment. Finally, transformational leadership can promote innovation at a firm level.

[22] affords the relationship between market orientation and innovation. Market orientation is considered in three elements that are: customer orientation, competitor orientation, interfunctional coordination. The author finds a positive relationship between market orientation and innovation at a firm level. The positive relationship between market orientation and innovation is strengthened in the case of competitive environment. Other elements that reinforce the positive relationship between market orientation and innovation are: large firms, service companies, countries with individualism and high power distance.

[23] afford the question of the relationship between cultural change and innovation. The authors analyze 34 countries in the period 1980-2010. Results show that there is a positive relationship between culture and innovation. The main drivers of the positive relationship between culture and innovation are: trust, control, work ethic and honesty. Obedience is negatively associated to innovation.

### III. THE MODEL

We estimate the sequent model:

$$\begin{aligned}
 \text{InnovationFriendlyEnvironment}_{it} = & a_1 + \\
 & b_1(\text{BasicSchoolEntrepreneurialEducationAndTraining}) + \\
 & b_2(\text{GovernmentProcurementOfAdvancedTechnologyProducts})_{it} + \\
 & b_3(\text{EmploymentShareManufacturing})_{it} + \\
 & b_4(\text{FinanceAndSupport})_{it} + b_5(\text{HumanResources})_{it}
 \end{aligned}$$

Where  $i=36$  and  $t=19$

Since:

- $\text{InnovationFriendlyEnvironment} = \text{BroadbandPenetrationAmongEnterprises} + \text{OpportunityDrivenEntrepreneurship};$
- $\text{FinanceAndSupport} = \text{R\&DExpenditureInThePublicSector} + \text{VentureCapitalExpenditures}$
- $\text{HumanResources} = \text{NewDoctorateGraduates} + \text{PopulationAged25 - 34WithTertirayEducation} + \text{LifelongLearning}$

Then we have the extended form of the equation is:

$$\begin{aligned}
 & \text{BroadbandPenetrationAmongEnterprises} + \\
 & \text{OpportunityDrivenEntrepreneurship} = \\
 & b_1(\text{BasicSchoolEntrepreneurialEducationAndTraining}) + \\
 & b_2(\text{GovernmentProcurementOfAdvancedTechnologyProducts})_{it} + \\
 & b_3(\text{EmploymentShareManufacturing})_{it} + \\
 & b_4(\text{R\&DExpenditureInThePublicSector})_{it} + \\
 & b_5(\text{VentureCapitalExpenditures})_{it} + \\
 & b_6(\text{NewDoctorateGraduates})_{it} + (\text{PopulationAged25 -} \\
 & \text{34WithTertirayEducation})_{it} + (\text{LifelongLearning})_{it}
 \end{aligned}$$

Where

$$\begin{aligned}
 \text{FinanceAndSupport}_{it} & = \text{R\&DExpenditureInThePublicSector}_{it} \\
 & + \text{VentureCapitalExpenditures}_{it} > 0
 \end{aligned}$$

And

Whit  $i=36$  and  $t=19$

$$HumanResources_{it} = NewDoctorateGraduates_{it} + PopulationAged25 - 34WithTertiaryEducation_{it} + LifelongLearning_{it} > 0$$

**The Estimation of the Innovation-Friendly Environment Synthesis of the Main Results. Source: European Innovation Scoreboard.**

	Dynamic panel		Fixed Effects		Random Effects		Pooled OLS		WLS	
	Coefficient	p value	Coefficient	p value	Coefficient	p value	Coefficient	p value	Coefficient	p value
Const	★ 4,25605	**	★ 0,3683		☆ 0,68568		★ 4,49289		★ 0,31925	
A4	☆ 0,401557	***	☆ 0,54	***	★ 0,53429	***	★ 0,49693	***	★ 0,50118	***
A22	☆ 1,21692	***	★ 1,1052	***	★ 1,11453	***	☆ 1,14109	***	★ 1,16079	***
A12	☆ 0,552527	**	★ 1,3019	***	★ 1,26194	***	☆ 0,96921	***	★ 0,865	***
A17	☆ 0,278096	**	☆ 0,4938	***	★ 0,48784	***	★ 0,44311	***	★ 0,3832	***
A23	☆ 0,664301	***	☆ 0,6134	***	☆ 0,61606	***	★ 0,62188	***	★ 0,68924	***
A25(-1)	★ 0,008616	0,89								

We found that the “Innovation-Friendly Environment” is positively associated to:

- *Basic School Entrepreneurial Education and Training:* in countries in which the training in creating or managing SMEs is incorporated in primary and secondary schools there are greater probabilities to create an innovation-friendly environment. Education and the school system have an essential role in shaping the ability of a country to boost innovation especially in the private sector through SMEs and corporations.
- *Government Procurement of Advanced Technology Products:* is a measure of the ability of a government to promote innovation through public investments. The increasing in the investment of government in advanced technology products is positively associated to the creation of an innovation-friendly environment.
- *Employment Share Manufacturing:* is a measure of the percentage of employment in knowledge intense industries. If a country can develop a productive system based on knowledge intense sectors, then that country has greater probabilities to create an innovation-friendly environment.
- *Finance and Support:* is a measure of the financial investment in innovation either in the private and in the public sector. If a country can improve the finance-innovation nexus then that country has greater probabilities to promote an innovation-friendly environment.
- *Human Resources:* is a measure of the presence of a high skilled workforce. Education, especially tertiary education, can have a relevant role in shaping a positive innovation-friendly environment.

An Estimation of the Innovation-Friendly Environment in Europe			
Variable		Definition. Source: European Innovation Scoreboard	
y	A25	<i>Innovation Friendly-Environment</i>	Captures the environment in which enterprises operate and includes two indicators - Broadband penetration among enterprises and Opportunity-driven entrepreneurship - measuring the degree to which individuals pursue entrepreneurial activities as they see new opportunities, for example resulting from innovation.
x <sub>1</sub>	A4	<i>Basic School Entrepreneurial Education and Training</i>	The indicator measures the extent to which training in creating or managing SMEs is incorporated within the education and training system at primary and secondary school levels.
x <sub>2</sub>	A22	<i>Government Procurement of Advanced Technology Products</i>	The indicator measures the extent to which government procurement decisions in a country foster technological innovation by providing the average response to the following question: “Government purchase decisions for the procurement of advanced technology products are (1 = based solely on price, 7 = based on technical performance and innovativeness)”.
x <sub>3</sub>	A12	<i>Employment Share Manufacturing</i>	Employment in technology and knowledge-intensive sectors at the national level, by type of occupation.
x <sub>4</sub>	A17	<i>Finance and Support</i>	Includes two indicators and measures the availability of finance for innovation projects by Venture capital expenditures, and the support of governments for research and innovation activities by R&D expenditures in universities and government research organizations.
x <sub>5</sub>	A23	<i>Human Resources</i>	Includes three indicators and measures the availability of a high-skilled and educated

			workforce. Human resources captures New doctorate graduates, Population aged 25-34 with completed tertiary education, and Population aged 25-64 involved in education and training.
--	--	--	---

#### IV. CONCLUSION

In this article we investigate the determinants of the innovation-friendly environment in Europe in the period 2000-2019. We use data from the European Innovation Scoreboard of the European Commission for 36 countries. Data are analyzed using dynamic panel data at 1 stage, panel data with fixed effects, panel data with random effects, pooled OLS, and WLS. The determinant of the innovation-friendly environment are not only economic or financial in a strict sense. There are also sociological, cultural, political and anthropological factors that can explain why a certain country is more oriented to innovation in respect to other. To analyze these cultural and sociological factors that have an impact on innovation, either at a country level either in an organizational perspective, we use refers to the Hofstede's Index that is able to capture six cultural dimensions able to describe the cultural environment. We discuss literature that connect the Hofstede's Index to innovation. Finally, we present our econometric models. Our results show that the "Innovation-Friendly Environment" is positively associated to "Basic-school entrepreneurial education and training", "Government procurement of advanced technology products", "Employment share Manufacturing", "Finance and support", "Human resources".

**Recommendation Policies.** If politicians are interested in promoting an innovation-friendly environment, they should not only invest directly on innovation. But at the contrary they must invest in the creation of a cultural, social, institutional environment able to promote innovation. A relevant aspect of the innovation-friendly political economies is in the empowering of human resources, in the promoting education and learning among the population and in creating the conditions for a deeper cooperation between public and private organizations in the sense of innovation.

#### REFERENCES

- [1] J. A. Schumpeter, Capitalism, socialism and democracy, Routledge, 2013.
- [2] P. M. Romer, «The origins of endogenous growth,» *Journal of Economic perspectives*, vol. 8, n. 1, pp. 3-22, 1994.
- [3] R. M. Solow, «A contribution to the theory of economic growth,» *The quarterly journal of economics*, vol. 70, n. 1, pp. 65-94, 1956.
- [4] H. Tekin e O. F. Tekdogan, «Socio-cultural dimension of innovation,» *Procedia-Social and Behavioral Sciences*, vol. 195, pp. 1417-1424, 2015.
- [5] S. Shane, S. Venkataraman e I. MacMillan, «Cultural differences in innovation championing strategies,» *Journal of management*, vol. 21, n. 5, pp. 931-952, 1995.
- [6] T. Rinne, G. D. Steel e J. Fairweather, «Hofstede and Shane revisited: The role of power distance and individualism in national-level innovation success,» *Cross-cultural research*, vol. 46, n. 2, pp. 91-108, 2012.
- [7] A. M. Kiurunen, «Culture effect on innovation level in European countries,» *International Journal of Business Innovation and Research*, vol. 3, n. 3, pp. 311-324, 2009.
- [8] S. Shane, «Uncertainty avoidance and the preference for innovation championing roles,» *Journal of international business studies*, vol. 26, n. 1, pp. 47-68, 1995.
- [9] P. Rujirawanich, R. Addison e C. & Smallman, «The effects of cultural factors on innovation in a Thai SME,» *Management Research Review*, vol. 34, n. 12, pp. 1264 - 1279, 2011.
- [10] A. R. Jassawalla e H. C. Sashittal, «Cultures that support product-innovation processes,» *Academy of Management Perspectives*, vol. 16, n. 3, pp. 42-54, 2002.
- [11] R. Westwood e D. R. Low, «The multicultural muse: Culture, creativity and innovation,» *International journal of cross cultural management*, vol. 3, n. 2, pp. 235-259, 2003.
- [12] A. Kaasa e M. Vadi, «How does culture contribute to innovation? Evidence from European countries.,» *Economics of innovation and new technology*, vol. 19, n. 7, pp. 583-604, 2010.
- [13] R. Khan e P. Cox, « Country culture and national innovation,» *Archives of Business Research*, vol. 5, n. 2, 2017.
- [14] J. Rank, V. L. Pace e M. Frese, «Three avenues for future research on creativity, innovation, and initiative,» *Applied psychology*, vol. 53, n. 4, pp. 518-528, 2004.
- [15] M. Tian, P. Deng, Y. Zhang e M. P. Salmador, «How does culture influence innovation? A systematic literature review,» *Management Decision*, vol. 56, n. 5, pp. 1088-1107, 2018.
- [16] N. Rosenbusch, J. Brinckmann e A. & Bausch, «Is innovation always beneficial? A meta-analysis of the relationship between innovation and performance in SMEs,» *Journal of business Venturing* , vol. 26, n. 4, pp. 441-457, 2011.
- [17] A. H. Tolba e M. Mourad, «Individual and cultural factors affecting diffusion of innovation,» *Journal of International Business and Cultural Studies*, vol. 5, 2011.



[18] J. A. Aragón-Correa, V. J. García-Morales e E. & Cordon-Pozo, «Leadership and organizational learning's role on innovation and performance: Lessons from Spain,» *Industrial marketing management*, vol. 36, n. 3, pp. 349-359, 2007.

[19] S. Khazanchi, M. W. Lewis e K. K. Boyer, «Innovation-supportive culture: The impact of organizational values on process innovation,» *Journal of operations management*, vol. 25, n. 4, pp. 871-884, 2007.

[20] M. H. Morris, R. A. Avila e J. Allen, «Individualism and the modern corporation: Implications for innovation and entrepreneurship.,» *Journal of management*, vol. 19, n. 3, pp. 595-612, 1993.

[21] L. Gumusluoglu e A. Ilsev, «Transformational leadership, creativity, and organizational innovation,» *Journal of business research*, vol. 62, n. 4, pp. 461-473, 2009.

[22] A. Grinstein, «The effect of market orientation and its components on innovation consequences: a meta-analysis,» *Journal of the academy of Marketing science*, vol. 36, n. 2, pp. 166-173, 2008.

[23] P. C. Kostis, K. I. Kafka e P. E. Petrakis, «Cultural change and innovation performance,» *Journal of Business Research*, vol. 88, pp. 306-313, 2018.

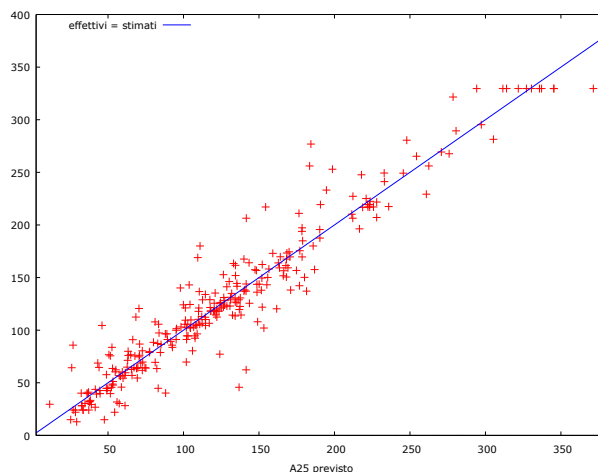

Appendix

Modello 26: Panel dinamico a un passo, usando 288 osservazioni  
Incluse 36 unità cross section  
Matrice H conforme ad Ox/DPD  
Variabile dipendente: A25

	Coefficiente	Errore Std.	z	p-value	
A25(-1)	0,00861597	0,0623214	0,1383	0,8900	
const	4,25605	1,93432	2,200	0,0278	**
A4	0,401557	0,0290885	13,80	<0,0001	***
A22	1,21692	0,0757161	16,07	<0,0001	***
A12	0,552527	0,217804	2,537	0,0112	**
A17	0,278096	0,118396	2,349	0,0188	**
A23	0,664301	0,103132	6,441	<0,0001	***

Somma quadr. residui 129926,1  
E.S. della regressione 21,50280

Numero di strumenti = 22

Test per errori AR(1): z = -0,0689148 [0,9451]

Test per errori AR(2): z = 0,421443 [0,6734]

Test di sovra-identificazione di Sargan: Chi-quadro(15) = 25,2322 [0,0469]

Test (congiunto) di Wald: Chi-quadro(6) = 3362,52 [0,0000]

Modello 27: Effetti fissi, usando 360 osservazioni				
Incluse 36 unità cross section				
Lunghezza serie storiche = 10				
Variabile dipendente: A25				
	Coefficiente	Errore Std.	rapporto t	p-value
const	0,368304	2,82159	0,1305	0,8962
A4	0,540018	0,112498	4,800	<0,0001 ***
A22	1,10521	0,127715	8,654	<0,0001 ***
A12	1,30192	0,161702	8,051	<0,0001 ***
A17	0,493813	0,0843998	5,851	<0,0001 ***
A23	0,613376	0,0638178	9,611	<0,0001 ***
Media var. dipendente	102,0153	SQM var. dipendente	84,06029	
Somma quadr. residui	215392,5	E.S. della regressione	25,98484	
R-quadro LSDV	0,915091	R-quadro intra-gruppi	0,852219	
LSDV F(40, 319)	85,94892	P-value(F)	5,1e-147	
Log-verosimiglianza	-1661,758	Criterio di Akaike	3405,517	
Criterio di Schwarz	3564,847	Hannan-Quinn	3468,869	
rho	0,582108	Durbin-Watson	0,698579	
Test congiunto sui regressori -				
Statistica test: F(5, 319) = 367,919				
con p-value = P(F(5, 319) > 367,919) = 4,32909e-130				
Test per la differenza delle intercette di gruppo -				
Ipotesi nulla: i gruppi hanno un'intercetta comune				
Statistica test: F(35, 319) = 14,9402				
con p-value = P(F(35, 319) > 14,9402) = 1,52341e-048				

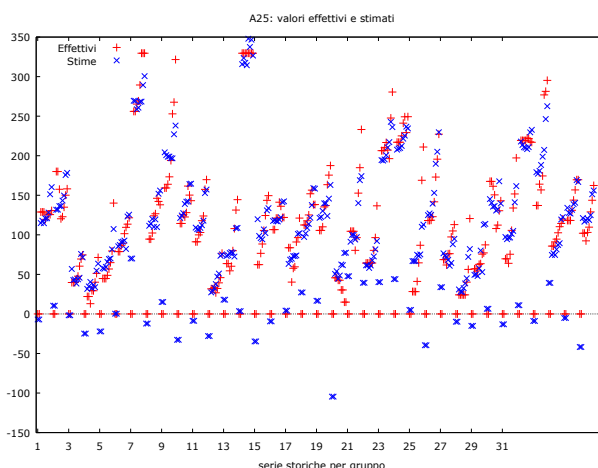

## The Determinants of the Innovation-Friendly Environment in Europe in the Period 2000-2019

Modello 28: Effetti casuali (GLS), usando 360 osservazioni				
Incluse 36 unità cross section				
Lunghezza serie storiche = 10				
Variabile dipendente: A25				
	<i>Coefficiente</i>	<i>Errore Std.</i>	<i>z</i>	<i>p-value</i>
const	0,685681	6,09168	0,1126	0,9104
A4	0,534288	0,101855	5,246	<0,0001 ***
A22	1,11453	0,114952	9,696	<0,0001 ***
A12	1,26194	0,154967	8,143	<0,0001 ***
A17	0,487839	0,0807540	6,041	<0,0001 ***
A23	0,616056	0,0607499	10,14	<0,0001 ***
Media var. dipendente	102,0153	SQM	var.	84,06029
Somma quadr. residui	575698,8	E.S. della	della	40,27017
Log-verosimiglianza	â <sup>1838,720</sup>		regressione	
Criterio di Schwarz	3712,757	Criterio di Akaike		3689,441
rho	0,582108	Hannan-Quinn		3698,712
		Durbin-Watson		0,698579
Varianza 'between' = 1069,57				
Varianza 'within' = 675,212				
Theta usato per la trasformazione = 0,756318				
Test congiunto sui regressori -				
Statistica test asintotica: Chi-quadro(5) = 1920,28				
con p-value = 0				
Test Breusch-Pagan -				
Ipotesi nulla: varianza dell'errore specifico all'unità = 0				
Statistica test asintotica: Chi-quadro(1) = 525,339				
con p-value = 2,91691e-116				
Test di Hausman -				
Ipotesi nulla: le stime GLS sono consistenti				
Statistica test asintotica: Chi-quadro(5) = 1,82306				
con p-value = 0,873046				

const	4,49289	3,67282	1,223	0,2220
A4	0,496930	0,0825678	6,018	<0,0001 ***
A22	1,14109	0,0910245	12,54	<0,0001 ***
A12	0,969208	0,165768	5,847	<0,0001 ***
A17	0,443113	0,0851295	5,205	<0,0001 ***
A23	0,621876	0,0616957	10,08	<0,0001 ***
Media var. dipendente	102,0153	SQM var. dipendente	84,06029	
Somma quadr. residui	568466,0	E.S. della regressione	40,07289	
R-quadro	0,775907	R-quadro corretto	0,772742	
F(5, 354)	245,1402	P-value(F)	1,3e-112	
Log-verosimiglianza	-1836,445	Criterio di Akaike	3684,889	
Criterio di Schwarz	3708,206	Hannan-Quinn	3694,160	
rho	0,970639	Durbin-Watson	0,248863	

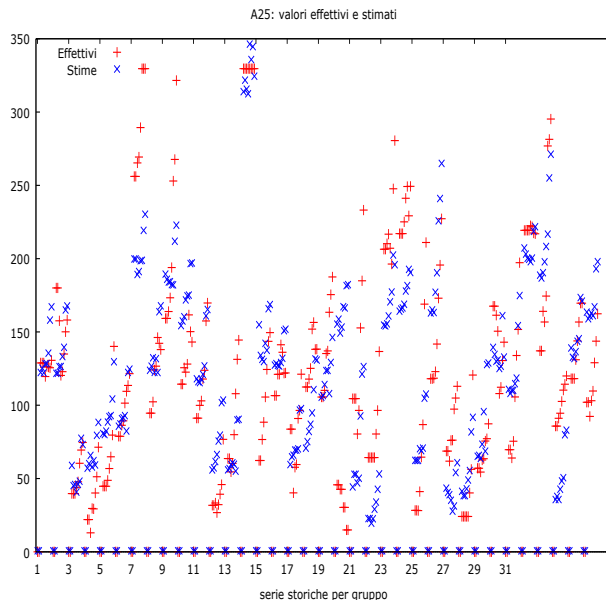
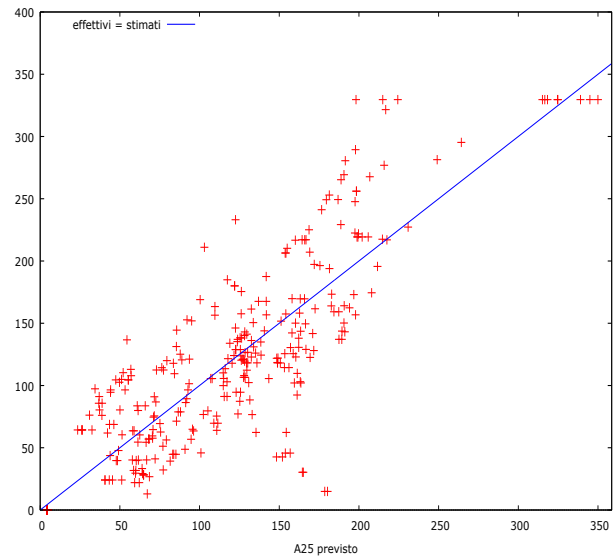

Modello 29: Pooled OLS, usando 360 osservazioni			
Incluse 36 unità cross section			
Lunghezza serie storiche = 10			
Variabile dipendente: A25			
	<i>Coefficiente</i>	<i>Errore Std.</i>	<i>rapporto t</i>
			<i>p-value</i>

Modello 30: WLS, usando 360 osservazioni				
Incluse 36 unità cross section				
Variabile dipendente: A25				
Pesi basati sulle varianze degli errori per unità				
	<i>Coefficiente</i>	<i>Errore Std.</i>	<i>rapporto t</i>	<i>p-value</i>
const	0,319254	1,88133	0,1697	0,8653
A4	0,501182	0,0218742	22,91	<0,0001 ***
A22	1,16079	0,0291557	39,81	<0,0001 ***
A12	0,864996	0,0910973	9,495	<0,0001 ***
A17	0,383200	0,0475172	8,064	<0,0001 ***
A23	0,689242	0,0360391	19,12	<0,0001 ***
Statistiche basate sui dati ponderati:				
Somma quadr. residui	348,7033	E.S. della	della	0,992491
R-quadro	0,948452	regressione		
F(5, 354)	1302,684	R-quadro corretto		0,947724
Log-verosimiglianza	-505,0790	P-value(F)		1,9e-225
Criterio di Schwarz	1045,475	Criterio di Akaike		1022,158
		Hannan-Quinn		1031,429
Statistiche basate sui dati originali:				
Media var. dipendente	102,0153	SQM var. dipendente	84,06029	
Somma quadr. residui	573525,5	E.S. della	della	40,25082
		regressione		



The Determinants of the Innovation-Friendly Environment in Europe in the Period 2000-2019

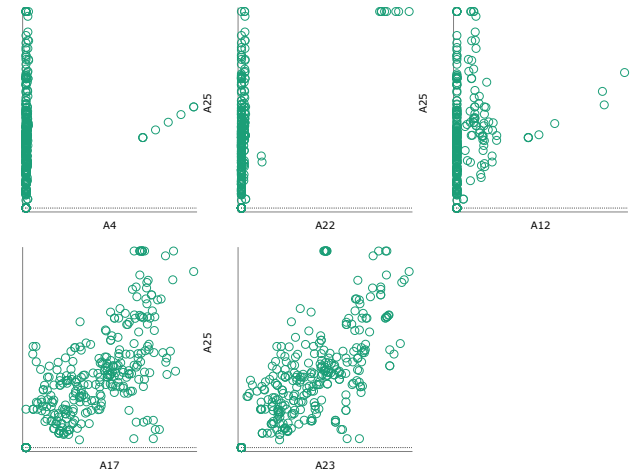
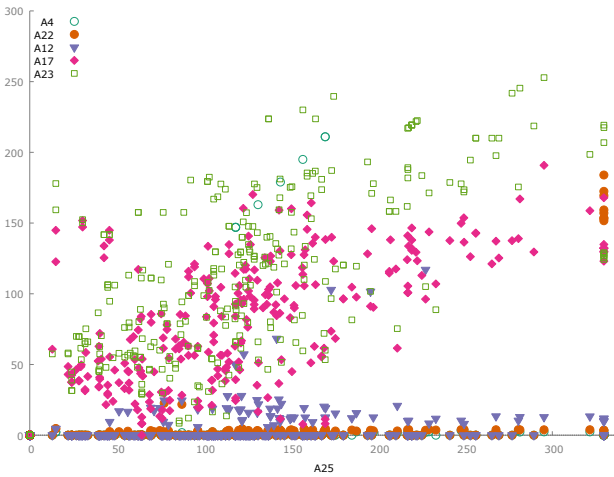
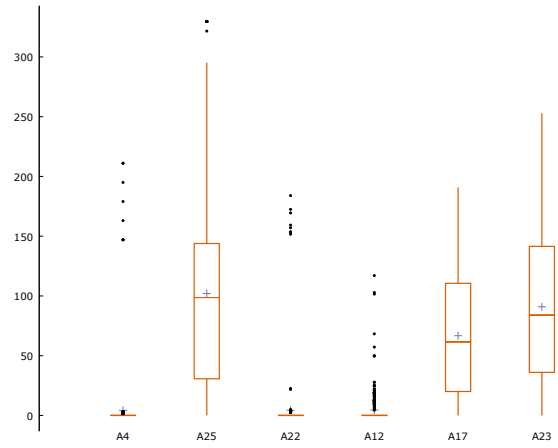
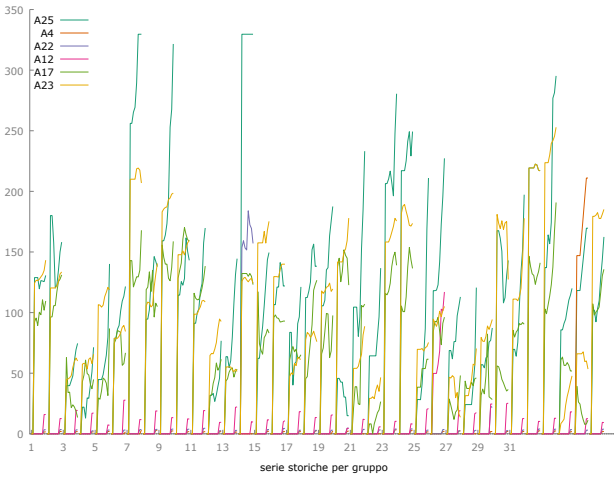
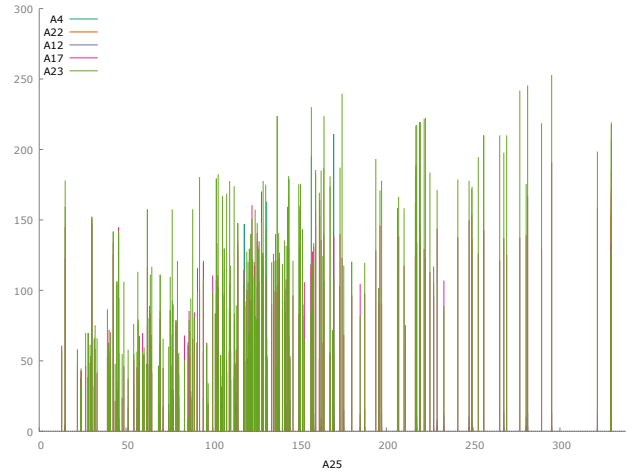
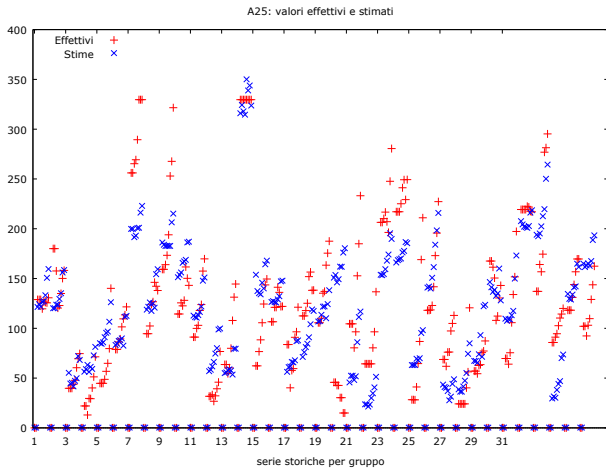

The Determinants of the Innovation-Friendly Environment in Europe in the Period 2000-2019

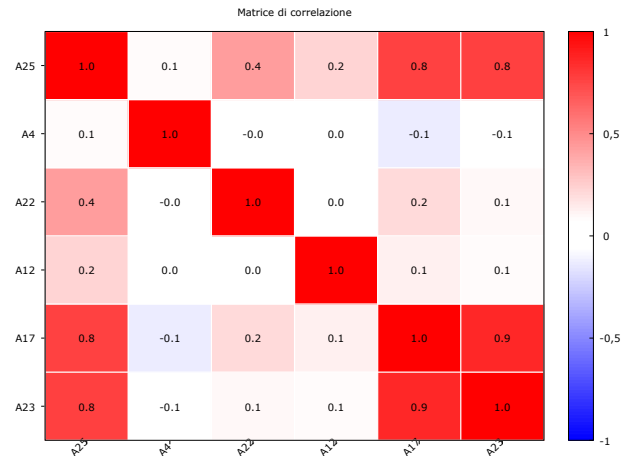
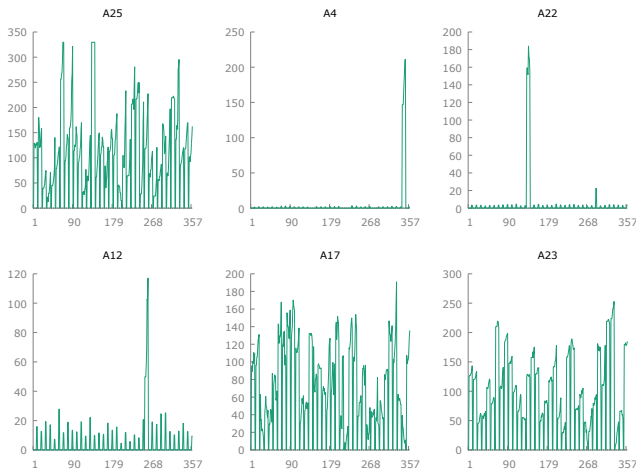

Statistiche descrittive, usando le osservazioni 1:01 - 36:10				
Variabile	Media	Mediana	Minimo	Massimo
A25	102,02	98,640	0,00000	329,62
A4	4,2286	0,00000	0,00000	211,00
A22	4,3792	0,00000	0,00000	183,97
A12	4,4794	0,00000	0,00000	117,01
A17	66,701	61,521	0,00000	190,83
A23	90,897	84,007	0,00000	252,86
Variabile	SQM	Coeff. di variazione	Asimmetria	Curtosi
A25	84,060	0,82400	0,76051	0,18165
A4	26,088	6,1694	6,7039	44,009
A22	24,031	5,4875	6,4562	40,202
A12	12,883	2,8761	5,3358	35,741
A17	50,796	0,76155	0,16317	-1,2121
A23	68,080	0,74898	0,26828	-0,91544
Variabile	5% Perc.	95% Perc.	Range interquartile	Osservazioni mancanti
A25	0,00000	269,24	113,18	0
A4	0,00000	2,4322	0,00000	0
A22	0,00000	4,0707	0,00000	0
A12	0,00000	20,193	0,00000	0
A17	0,00000	144,88	90,518	0
A23	0,00000	217,47	105,44	0

Analisi delle componenti principali						
n = 360						
Analisi degli autovalori della matrice di correlazione						
Componente	Autovalore	Proporzione	Cumulata			
1	2,7307	0,4551	0,4551			
2	1,0506	0,1751	0,6302			
3	0,9938	0,1656	0,7959			
4	0,9414	0,1569	0,9528			
5	0,1636	0,0273	0,9800			
6	0,1198	0,0200	1,0000			
Autovettori (pesi della componente)						
	PC1	PC2	PC3	PC4	PC5	PC6
A25	0,562	-0,186	-0,057	-0,016	0,697	0,401
A4	-0,037	-0,863	0,002	0,471	-0,179	-0,019
A22	0,234	-0,275	-0,676	-0,569	-0,206	-0,216
A12	0,140	-0,303	0,725	-0,587	-0,093	-0,095
A17	0,558	0,179	0,057	0,141	-0,655	0,453
A23	0,546	0,146	0,105	0,299	0,052	-0,760

# Challenges And Opportunities In The Field Of Information And Communications Technology (Ict) Due To Covid-19 Pandemic And Migration Towards The New Normal

**Ravenal A. De Jesus, ASEAN Eng., PECE, LPT**

Concurrent Head - SECURE GovNet Focal – Public Key Infrastructure Registration Authority (PKI-RA) at Department of  
Information and Communications Technology, DICT Provincial Office, ATC, Baler, Aurora, Philippines  
Email: ravenal.dejesus@dict.gov.ph

**Abstract—** This paper presented events and scenarios involving the roles of engineering and technology. This paper also covered various industry settings where challenges and opportunities in the field of Information and Communication Technology (ICT) are prevalent and significant.

First, summary of historical events involving pandemic and/or plague was introduced. The term *quarantine* was emphasized in this paper as this involves *movement control* that could hamper the economy. Such *movement controls* are called in various names depending on the degree of strictness enforced by respective countries (lock – down, community quarantine, zoning containment and so forth).

Second, stages and impacts of different Industrial Revolutions were discussed. Although *digital transformation* was associated only during the Third Industrial Revolution, it led to numerous technological advancements. Drawbacks of technological advancements were also discussed specifically the *right sizing* of numerous companies and organizations.

Third, selected *technologies* were showcased. These include the following but not limited to: Public Key Infrastructure (PKI), Rural Impact Sourcing (RIS) and Disaster Risk Reduction Management (DRRM). While these technologies were tailor-fit for Philippine scenarios, faithful reconstruction is possible in order to be tailor-fit in other countries both affected and unaffected by COVID-19 Pandemic.

Fourth, provisions for agenda of Gender and Development (GAD) are also presented pursuant the thrusts of international mandates to empower different sectors of the society. Specifically, ICT based and ICT enabled jobs give equal opportunities.

Fifth, ICT challenges and opportunities stipulated in this paper were evaluated from local to global perspective towards resilient and sustainable economy.

**Keywords—** disaster resilience, economy, ICT, new normal

## I. INTRODUCTION

While there are still distinctions between *health care* and *engineering* professions, the latter had proven its significant roles in world economy through times. At present however, *health care* professionals (physicians, nurses and laboratory technicians) are considered in-demand and essential during the COVID-19 Pandemic. Communities and media salute these *health care* professionals for their dedicated services offered to humanity. History shows their roles in dealing with the pandemic. Health care profession had also undergone several stages of development. Although it is still debatable the exact date when *quarantine* was first implemented, the concept of *quarantine* involves *movement control*.

As observed in Table 1, there is a *hypothetical disease* named Disease X speculated to affect a large – scale population should this **disease** occur and spread [1][2].

**Table 1 Events Involving Plagues / Pandemics [1]**

Event	Remarks
Athenian Plague	Estimated that this occurred around 430 – 426 B.C., the exact cause was unknown. The <i>overcrowded</i> city – state of Athens was severely hit.
Antonine Plague	Occurred in 165 – 180 A.D. which hit larger area i.e. territories of Roman Empire.
Justinian Plague	Occurred around sixth century A.D. and considered the first large scale plague in the recorded history.
The Black Death	This is the plague that hit Europe and Asia during the mid – 1300s
“Spanish Flu”	Regarded as the first global pandemic (1918 – 1920) that gave detrimental impacts to the several countries

Smallpox in the former Yugoslavia	Occurred in 1972, <i>travel restrictions</i> were enforced
HIV Pandemic	Observed in 1980's as "slow progressing" yet feared by the people around the globe.
SARS	Occurred in 2003
"Swine Flu"	Occurred in 2009
Ebola Outbreak	Occurred in 2014 – 2016
ZIKA	Identified in 2015
Disease X	A hypothetical, speculated disease serves a <i>model</i> for research

On the other hand, Table 2 features salient points of Industrial Revolution. The Industrial Revolution is a transition of practices, systems and policies due to either scientific or technological changes. The first recorded industrial revolution regarded as the "First Industrial Revolution" (1IR) flourished in Europe when the steam engine was invented. This revolutionized the working environment as the mechanical output had been improved significantly that time. "Water and steam" driven industries were prevalent.

**Table 2 Salient Points of Industrial Revolutions [3]**

Stages	Salient Points
First Industrial Revolution (1IR)	<ul style="list-style-type: none"> <li>• "Mechanization" was introduced</li> <li>• "Water and steam" driven industries</li> </ul>
Second Industrial Revolution (2IR)	<ul style="list-style-type: none"> <li>• Some "water and steam" driven industries were still present at this period but most were driven by internal combustion engines</li> <li>• Electrification was introduced.</li> </ul>
Third Industrial Revolution (3IR)	<ul style="list-style-type: none"> <li>• "Electromechanical systems" are now electronically controlled</li> <li>• Automation is present almost every industries</li> <li>• Information and Communications Technology (ICT) emerged.</li> </ul>
Fourth Industrial Revolution (4IR)	<ul style="list-style-type: none"> <li>• Features Artificial Intelligence</li> <li>• Continuous digital transformation (ICT is still present)</li> </ul>

The *Second Industrial Revolution* (2IR) followed. Although "water and steam" system was still present, *internal combustion engines* and *electrification* were introduced.

It was the *Third Industrial Revolution* (3IR) when *electronically controlled electromechanical systems*. These

electronic computers (emphasizing the word electronic in order to be distinct from mechanical computers such as difference and analytical engine) revolutionized not only the *electromechanical systems* but as well as *business*.

There are several issues whether or not the *Fourth Industrial Revolution* (4IR) is already present in the world. Its features are present yet not all places in the world are efficiently covered by *utility services* such as electricity and ICT.

## II. METHODS

Data from historical records were gathered and put into comparative studies together with studies involving surge of ICT utilization during this present COVID – 19 Pandemic [1][2][3][24]. Both historical backgrounds of *plague / pandemic* and *industrial revolutions* featured several stages and scope of concern. It also reflected that *technological advancements* were not a guarantee to be safe from the impacts of the contagion. *Health sciences* were limited in this study but these historical events are considered essential as well as history of *Industrial Revolutions*. While this paper was more focused on the latter, consideration of *historical* events is essential both in *health sciences* and in *engineering* spearheading the engagement on life – long learning. Contrary to the popular misconception that engineering involves little historical background since engineers are trained to analyze and perform mathematical calculation, *history serves as a reference for research and development as well as guide when dealing with formulation of safety protocols* [19][20][21]. Prior to COVID – 19 Pandemic, two major components of Information and Communications Technology (ICT) namely *information infrastructure* (*infostructure*) and *capacity building* were being built and conducted respectively in the Philippines by the Department of Information and Communications Technology (DICT). There was also a paper presented during the 37th Conference of ASEAN Federation of Engineering Organisations (CAFE0 37) which stated how ICT contribute to disaster resilience and sustainable Asia – Pacific Region [4].

The definition of ICT is stated in the Republic Act No. 9292 (Electronics Engineering Law of 2004) and Republic Act No. 10844 (DICT Law of 2016) respectively under the Philippine laws [5] [6]. On the other hand, ICT was also stated by the International Telecommunications Union (ITU) through one of the reports by the Secretary General [7].

Selected ICT projects and practices were presented in this paper in order to assess and evaluate the resilience from the pandemic. As per *movement control* (*quarantine*) protocols and *distancing* enforced by concerned government agencies, physical contacts among peers, clients and partner stakeholders were discouraged. Most of transactions are *online* rather than *face – to – face* (F2F) in order to minimize the risk of contagion. However, less F2F

transactions might put parties at security risk in the *cyberspace*.

### III. DISCUSSION

#### The Implementation of Public Key Infrastructure (PKI)

This infrastructure is the synthesis of hardware, software, dataware and peopleware necessary to create, manage, distribute, use, store and revoke digital certificates in which such digital certificate can serve as a valid identification and signature of an individual [8]. Considering that the *Electronic Commerce Act of 2000 (E – Commerce Law)* and the *Ease of Doing of Doing Business and Efficient Government Service Delivery Act of 2018 (EODB Law)* were approved in the Philippines, the significant increase in registration for PKI was prevalent during the *Enhanced Community Quarantine (ECQ)*, the most stringent safety protocol implemented in the Philippines during the COVID – 19 Pandemic on the first semester of 2020). PKI features, higher level of security of digital signatures as *cyber threats* were pronounced during this pandemic. A mere scanning of a signature and pasting the same in a document to be forged is easy for perpetrators of *cybercrimes*. The challenges in full adaptation of PKI in the Philippines are the availability of devices for every individual and intensive capacity building for every citizen. As *information security* protocol, sharing of devices is considered as unsafe practice.

#### The Rural Impact Sourcing (RIS) and Disaster Risk Reduction Management (DRRM)

The RIS is another project of the Department of Information and Communications Technology (DICT) that had been shortlisted in the 2019 World Summit on the Information Society (WSIS) Prizes under the Capability Building Category of the International Telecommunications Union (ITU) [9].

RIS aims to create ICT-enabled jobs in the socio-economically disadvantaged areas in order to mitigate the repercussions of *hegemony* [10][11]. As reflected in global data, most people migrate from countryside to the city. The *hegemony* creates brain drain as well as economic imbalance. Congested cities pose a number of security and environmental risks. Involvement of the people in ICT jobs and digital entrepreneurship will contribute both to the economy as well as to the decongestion of urban areas especially the Metro Manila.

The *decongestion* of Metro Manila is necessary in order to mitigate the possible casualties if a 7.2 magnitude earthquake strikes, and to sequester emission of pollutants [12]. While *frontliners* such as rescuers are prevalent during the disaster response operation, DRRM also covers the *forecasting* and *anticipating* risks and hazards that could create chaos and catastrophe.

Both ASEAN and APEC are engaged in building infrastructures that aims toward *digital transformation*. These projects are career opportunities for *engineers* and

*technicians*. Consequently, *operations and maintenance (O & M)* phase would further create more job opportunities. Table 4 presents scenarios of either opportunities or challenges in the implementation and utilization of ICT infrastructures and applications.

**Table 4 ICT Opportunities and Challenges**

Opportunities / Challenges	Remarks
Improved access for ICT infostructure and services	<ul style="list-style-type: none"> <li>Building and operating information infrastructure (infostructure) creates career opportunities for <i>engineers</i> and <i>technicians</i>, and will further address the requirements towards the new normal.</li> </ul>
Disaster-Resilient Livelihood and Businesses	<ul style="list-style-type: none"> <li>Government created the Public Service Continuity Plan (PSCP) which is analogous to Business Continuity Plan (BCP).</li> <li>Government provides capacity building for people to be ICT equipped towards the new normal (and even before the pandemic).</li> </ul>
Increased Institutional Capacities of National and Local Disaster Risk Reduction and management (DRRM)	<ul style="list-style-type: none"> <li>Planning and fostering partnership with different stakeholders would be a challenge as data in the <i>hazard registry</i> differs from stakeholders to stakeholders</li> </ul>
Affected Communities are Provided with Gender- and Conflict-Sensitive Basic Necessities and Services (Agenda of Gender and Development, also known as GAD)	<ul style="list-style-type: none"> <li><i>Senior citizens</i> (60 years and above), pregnant, persons with medical conditions and persons below 21 years (despite that 18 years is the legal age in the Philippines) are considered <i>vulnerable sectors</i> during the <i>quarantine</i>.</li> <li>Improved ICT infra and capacity building for citizens, people can secure ICT jobs regardless of gender and age.</li> </ul>

Upon commissioning of *infrastructures*, *capacity building* would be the new challenge as digital literacy among citizens is difficult to implement considering that these topics are already infused in the school curriculum. In the case of the DICT in the Philippines, *capacity building* had been implemented prior to COVID – 19 pandemic. With this COVID – 19 Pandemic, *digital literacy* for the citizens not only in the Philippines would be part of the new normal. “*Narrowing the Digital Divide*” is the objective being fulfilled in the Philippines as well as across the globe.



ICT challenges were not only encountered in working sector but as well as education sectors. Since safety and security is the priority of both government and parents, Flexible Learning Schemes are implemented in educational institutions. DICT fostered partnership with Aurora State College of Technology (ASCOT) in launching ICT projects and programs including the Flexible Learning Schemes which was drafted by both ASCOT and DICT under the supervision of the Commission on Higher Education (CHED) [13][14]. Challenges in the education sector did not end with flexible learning schemes as not all students have access in ICT as their home are located in remote areas.

With the threats of COVID – 19 prompting countries to enforce its respective *movement control schemes*, *face – to – face* (F2F) transactions had been minimized. While online transactions are convenient method of dealing with clients, co – workers and / or stakeholders, there are *cybersecurity risks* involved. These risks and threats are the following but not limited to *phishing*, *whishing* and *identity theft*. Risks of identity theft might be prevented by securing the credentials of an individual by using Public Key Infrastructure (PKI). However, despite of the existing *EODB Law and E – Commerce Law*, implementation of PKI had encountered challenges i.e. adapting by various government agencies and private sectors. Consequently, *marginalized sectors* have also difficulties of coping with ICT as they have limited equitable access to *utility services*.



Figure 1: PKI Services [8]

On the other hand, another issue to be addressed this pandemic are agenda for Gender and Development (GAD). Senior citizens, pregnant and minors (less than 18 years old under Philippine law but as per *quarantine* guidelines, below 21 years old are not allowed to go outside) are restricted of travelling. The conflict seems that people below 21 years are prohibited to go outside their home yet people at least 18 years old can already work. Same dilemma applies with pregnant who used to work in their companies before pandemic hit. ICT through *work from home (WFH)* scheme can address this GAD issues. Figure 2 indicates the demographic vulnerabilities in the National Capital Region (NCR). This region in the Philippines has the highest cases of COVID – 19.



Figure 2: Demographic Vulnerabilities [15]

Moreover, *capacity building* for younger generations would not be difficult provided that *equitable access* to education and ICT platforms and services are available. In this scenario, there is a weigh shifting of balance between *challenges* and *opportunities*. There were beneficial effects of *computer gaming* in the skills development of the youth [22]. These are the following but not limited to: reflex, analytical, logical and even vocabulary skills. However, this *pandemic* may pose another challenge such as risks of mental health deprivation due to lack of socialization among people. While people are waiting either for the vaccine or for the containment of this *pandemic*, a *new normal* may arise i.e. trends in *business* and *education* enabled by ICT. It was discussed in this paper that ICT is the totality of electronic means to access, create, collect, store, process, receive, transmit, present and disseminate information [6]. Moreover, ICT is under the scope of practice of Electronics Engineering [5].

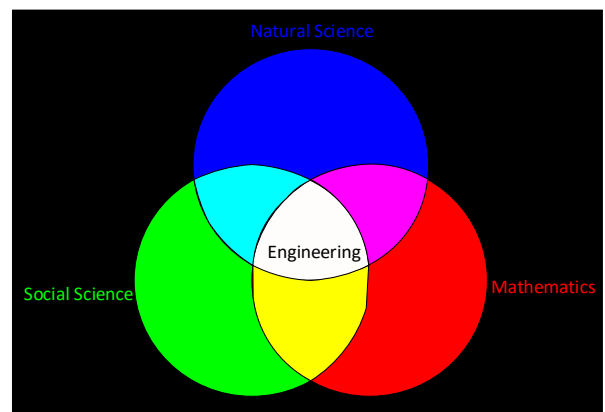

Figure 3: Venn Diagram representing the “Engineering Profession” as synergy of various disciplines [23]

IV. CONCLUSIONS

The COVID – 19 Pandemic had brought detrimental impacts both to the health of people and to the global economy. *Quarantine* had been practiced through the years in order to contain the disease but involved *movement controls*. These movement control schemes hamper logistics and trade, bringing detrimental impact to the

economy. On the other hand, there were several *industrial revolutions* that transformed economic norms. These industrial revolutions had brought both beneficial and detrimental effects upon its introduction. As there are still debates whether Fourth Industrial Revolution (4IR) is now present, the Third Industrial Revolution (3IR) has still challenges to cope i.e. implementation in the countryside, retooling of workforce, and *capacity building* for citizens. Should 4IR would be fully introduced, ICT would be its one of major platform.

This paper assessed and evaluated the trade – off between safety and economy. Even though the former is paramount over the latter, both *health care professionals* and *engineering professionals* have vital roles in overcoming this crisis for better living. The COVID – 19 being categorized as *pandemic* i.e, occurring in wide area such as multiple countries, problems occurred in a particular country might be similar with other countries.

### ACKNOWLEDGMENTS

I would like to express my deep and cordial gratitude to my colleagues, love ones who gave contribution in this work: Thanks to the Department of Information and Communications Technology (DICT, formerly DOST-ICTO) as well to the full support of Engrs. Philip Varilla, Reynaldo Sy, Antonio Padre, Petronilo Villafuerte, Rafael Olivar, Nimir Calupitan, Pablito Dela Peña, Armando Rillera, Danilo De Leon Jr., Ricardo Juangco, Melanio Mamalateo and Mario Antonio Aya-Ay. Thanks to Bulacan State University (BulSU) through Electronics Engineering (ECE) Department. Thanks to ACCENTURE where I practiced my Electronics Engineering profession in the field of ICT with Marc Culili, Gilbert Paltao and other colleagues. Thanks to Armed Forces of the Philippines - Corps of Professors (AFP – COP) who boosted my confidence in teaching. Thanks also to my colleagues in PAGE, Oliver Mariano and Romeo Rosas who are both ASEAN Engineers who continuously supported our career development. Thanks to Bases Conversion Development Authority (BCDA) who fostered partnership with DICT in constructing the state-of-the-art project named SECURE GovNet (DICT – BCDA – Facebook Joint Project): Luzon Bypass Infrastructure under the National Broadband Plan that will address the challenges of providing people an equitable ICT access[16][17][18]. The synergy of three parties gave me significant engineering experience.

### REFERENCES

[1] Huremović D. Brief History of Pandemics (Pandemics Throughout History). *Psychiatry of Pandemics*. 2019 May 16:7–35. doi: 10.1007/978-3-030-15346-5\_2. PMID: PMC7123574.

[2] WHO: R&D Blueprint, about the R&D Blueprint. URL: <https://www.who.int/blueprint/about/en/>. Date Accessed: October 26, 2020

[3] Gleason, N.W., *Higher Education in the Era of the Fourth Industrial Revolution*, Palgrave Macmillan 2018 ISBN 978-981-13-0193-3, ISBN 978-981-13-0194-0 (eBook), <https://doi.org/10.1007/978-981-13-0194-0>

[4] De Jesus, R.A. *Roles of Information and Communications Technology in Resilience Toward Sustainable Asia – Pacific Region*. 37<sup>th</sup> Conference of ASEAN Federation of Engineering Organisations, Jakarta, Indonesia, 2019

[5] Republic Act No. 9292 of the Philippines: Electronics Engineering Law of 2004

[6] Republic Act No. 10844 of the Philippines: Department of Information and Communications Technology Act of 2015

[7] International Telecommunication Union (ITU): Document C16/INF/13, —ITU Council Contribution to the 2016 United Nations High – Level Political Forum on Sustainable Development, pp. 1, 6, 7, 8

[8] Philippine National Public Key Infrastructure URL: <https://dict.gov.ph/pnpki/> Date Accessed: October 26, 2020

[9] Rural Impact Sourcing Project shortlisted for 2019 WSIS URL: <https://dict.gov.ph/dicts-rural-impact-sourcing-project-shortlisted-for-2019-wsis-prizes/> Date Accessed: October 26, 2020

[10] DICT RIS Technical Training produces more than 500 online Filipino workers in 2017”.URL: <https://dict.gov.ph/dict-ris-technical-training-produces-500-online-filipino-workers-2017/> Date Accessed: October 26, 2020

[11] RURAL IMPACT SOURCING as cited in International Telecommunications Unions (ITU) Website URL: <https://www.itu.int/net4/wsis/archive/stocktaking/Project/Details?projectId=1514950103> Date Accessed: October 26, 2020

[12] “Mga Dapat Malaman sa Big One (Things to Know About the Big One)”, an audio-video presentation of PhiVOLCS about a 7.2 Magnitude earthquake that might strike. URL: <https://www.youtube.com/watch?v=T-WoRReLpKY> Date Accessed: October 26, 2020

[13] DICT Provides Free WI-FI Connectivity to ASCOT. URL: <https://www.ascot.edu.ph/dict-provides-free-wi-fi-connectivity-to-ascot/> Date Accessed: October 26, 2020

[14] DICT Provides Free WI-FI Connectivity to ASCOT. URL: <https://www.ascot.edu.ph/dict-provides-free-wi-fi-connectivity-to-ascot/> Date Accessed: October 26, 2020

[15] IATF-EID ENDORSES POPCOM’S DEMOGRAPHIC VULNERABILITY TOOL TO HELP TRACK DOWN COVID-19 CASES IN EVERY BARANGAY. URL: <https://ncr.popcom.gov.ph/index.php/2-uncategorised/178-iatf-eid-endorse-popcom-s->

demographic-vulnerability-tool-to-help-track-down-covid-19-cases-in-every-barangay Date Accessed: October 26, 2020

- [16] National Broadband Plan (NBP), Department of Information and Communications Technology (DICT), 2017
- [17] Strategic Engagement and Collaboration to Undertake a Reliable and Efficient Government Internet (SECURE GovNet) project URL: <https://www.youtube.com/watch?v=R6NEJbaULRA> Date Accessed: October 26, 2020
- [18] COVID-19 makes universal digital access and cooperation essential: UN tech agency URL: <https://news.un.org/en/story/2020/05/1063272> Date Accessed: October 26, 2020
- [19] De Jesus, R.A., Professional Engineering Practice: Engineering Science of Energy and Environment, p. 141 ISBN 978-971-0572-51-9, 2014
- [20] De Jesus, R.A., Professional Engineering Practice: ELECTROMAGNETICS: Engineering Outcomes Oriented, p. 10 ISBN 978-971-0572-54-0, 2015
- [21] De Jesus, R.A., Engineering Science of Energy and Environment (Electrical / Electronics Engineering Approach), pp. 175 – 176 ISBN 978-971-0572-95047-4-0, 2016
- [22] De Jesus, R.A., Evaluation of the Effects of Electronic Games to the Vocabulary Comprehension and Attributes Analyses Background of Selected Engineering Students, pp. 18 – 23, ISSN 1908 - 1766, Vol 3, No. 1, December 2012
- [23] De Jesus, R.A., Laws and Ethics: ICT Perspective Towards Leadership and Development, p.9 – 11, ISBN 978 – 971 – 0572 – 94 -6, 2018
- [24] De' R, Pandey N, Pal A. Impact of digital surge during Covid-19 pandemic: A viewpoint on research and practice. Int J Inf Manage. 2020 Dec;55:102171. doi: 10.1016/j.ijinfomgt.2020.102171. Epub 2020 Jun 9. PMID: 32836633; PMCID: PMC7280123.

# Social And Cultural Values For The Sustainability Of Local Tourism In The Province Of Cañete

<sup>[1]</sup>María de los Ángeles Caycho Reyna, <sup>[2]</sup>Néstor Cuba Carbajal, <sup>[3]</sup>Mauro Granados Maguiño, <sup>[4]</sup>Judith Soledad Yangali Vicente

<sup>[1][2]</sup> Universidad Nacional de Cañete,

<sup>[3]</sup> Universidad Nacional Mayor de San Marcos

<sup>[4]</sup> Universidad Norbert Wiener

Email: <sup>[1]</sup> 1670133766@undc.edu.pe, <sup>[2]</sup> ncuba@undc.edu.pe, <sup>[3]</sup> granadosmaurom@gmail.com,

<sup>[4]</sup> judith.yangali@uwiener.edu.pe

**Abstract**— The research had its origin in the interest of studying the current situation of the problems that exist in the province of Cañete, regarding the significant loss of social and cultural values over time. The main objective of the study was to analyse social and cultural values in order to achieve sustainability of local tourism in the province of Cañete, Peru. The qualitative approach was developed, with a case study design, where the interview technique was used and two semi-structured interview guides were applied as instruments. It was concluded that strengthening cultural identity contributes to the local development of the province of Cañete, being necessary for the population to feel proud of their customs and cultural manifestations. Therefore, it is necessary that public and private institutions, as well as the population, join forces to formulate plans, programmes and projects of cultural development; that the social and cultural values in Cañete are strengthened and revalued, being a decisive factor that the people of Cañete can be able to protect and promote local tourism.

**Keywords**— local development, tourism sustainability, cultural values, social values

## I. INTRODUCTION

Social and cultural values lead to the formation of a people's cultural identity and have acquired greater relevance worldwide, due to the initiative of international organisations to disseminate and conserve the tangible and intangible heritage of the various countries; it was necessary to take timely measures to prevent it from deteriorating and disappearing, which is painful and irreversible for humanity. The loss of social and cultural values is a latent problem that has been generated by various factors, including globalisation, migration, the spread of foreign stereotypes and the negative influence of the media.

According to the United Nations Educational, Scientific and Cultural Organisation (UNESCO), the Intangible Cultural Heritage Lists are inventories that serve as a basis for formulating concrete plans for safeguarding registered heritage and can also serve as a reference for raising public awareness of its general aspects and its importance for the individual and collective identities of each of the countries from which it originates. In 2019, 549 cultural expressions around the world were registered as cultural legacies of all humanity, of which five required urgent safeguarding actions: the Juraški Karahod spring ritual (Belarus), the Buklog thanksgiving ritual of the Subanen people (Philippines), the Seperu folk dance and related ritual practices (Botswana), the sega drumming music of the Chagos Islands (Mauritius), and the rites and practices of the Kit Mikayi shrine (Kenya)[1]. In Latin America, there is a strong potential for tourism development, due to the growing motivation of travellers in recent years to

appreciate the culture, ancestral knowledge and idiosyncrasies of the peoples. Contradictorily, a gradual loss of customs and cultural manifestations characteristic of each country has been identified. Adolescents have shown very little interest in their cultural roots, due to the influence of foreign culture, which is increasingly consolidating and threatening the rights, manifestations, lifestyles, and therefore the social and cultural values of emerging countries[2].

The Peruvian territory has nine thousand native and peasant communities, which are holders of cultural manifestations, particular features, festivities, gastronomy among many characteristics that are part of their cultural identity, but the company Ipsos Peru at the end of 2017 conducted a survey of a group of 3781 individuals, revealed that 52% of Peruvians do not know or know very little about the term cultural diversity[3]. Cañete has a cultural diversity inherited from its ancestors, which is lost due to a lack of education and awareness of the population about the cultural richness they possess, and which they should take advantage of to strengthen unity and achieve a development that generates benefits for all. At the local level, there is a need to value and promote the cultural manifestations of the province of Cañete in order to strengthen the local identity of children and young people; their adoption and dissemination will be a source of commitment, adding a step towards the goal of achieving sustainable tourism development. The inhabitants show a significant loss of the customs that Cañete has, they do not know part of its history and show a lack of interest in learning about the benefits of the locality, causing a deterioration and damage to the heritage they possess. The responsibility also lies



with the authorities and both public and private entities, which should work on educational programmes where all citizens can participate in cultural activities, so that they become bearers of knowledge that strengthen social and cultural values.

## II. THEORETICAL FRAMEWORK

The psychiatrist Ronald David Laing is recognised as one of the first to carry out studies based on social and cultural values; in 1961 he defined them as the reason why people feel part of themselves in a certain space and at a certain time, whether in the past or in the future. It considers the thoughts that human beings have about who they are and what they identify with [4]. Edward Tylor, in 1871, stated that culture is the set of habits, abilities, beliefs, knowledge and customs acquired by people within their community, including art, morals and laws. His contribution has made it possible to perceive culture as a capacity that is shared by human groups [5].

In this research, the theory of Stuart Hall was used, who since 1990, managed to integrate the study of culture and social and cultural values into the social sciences, and also argued that identities are subject to constant change, are strengthened and adapted to new realities with the passage of time and various influential factors [6].

Larraín (1994) reflects on the theories that state that social and cultural values in Latin America must remain unchanged, and he made his contribution by referring to the fact that the foundation of cultural identity is a changing process that acquires new characteristics over time [7]. Bákula Budge (2000) mentioned that "cultural identity cannot be an immutable and perfectly delimited concept, but is rather an engine that drives creative forces, and this drive has its own dynamics, orientation and definition at each moment" (p. 171) [8]. The social and cultural values of a population group are defined by multiple aspects that reflect culture, including social relations, language or the language used for communication, typical rites and festivities, behaviours that are developed collectively; that is, the set of values and beliefs characteristic of a group of individuals residing in a certain place [9].

Kogan and Tubino with their theory of cultural identities and recognition policies expose the conditioning of human beings to acquire culture from birth from their parents and their community, this identity becomes part of their self-identification and allows the strengthening of their sense of belonging and their individual identity, which has laid its foundations in the respect for oneself and for their community, achieving their own distinction with respect to others [10]. Serín Laguna (2017) states that social and cultural values are made up of a set of symbols, ways of behaving and people's traditions, which are acquired over time and give them the ability to base their feeling of being part of a group or society and of themselves, in addition to this being part of their daily lives.

In the case of a loss of social and cultural values, actions must be taken to revalue the cultural manifestations that are part of the essence of a town. Social and cultural values can be defined as the feeling or affirmation of feeling part of a social group, that is, admitting to possessing particular characteristics and unique cultural traits that distinguish a person from others, and that gives them the option of being judged or valued [11]. It represents pride and a series of values, behaviours, customs and beliefs that form part of a community, with the sole purpose of generating a sense of belonging among its members. It can be said that it is the sense of belonging that each person has in relation to the space in which they live and their community; it is to identify with a set of manifestations that are considered as their own [12].

The sub-categories of study are defined: Collective memory is the process of reconstructing the past of a social group through a memory. It represents the stories, practices and attitudes that were transmitted by a community from generation to generation, such as social practices or rituals.

The sense of belonging is the link between a person and his or her community, from which situations arise that provoke various attitudes oriented towards its care and benefit. The foundation of the meanings that will form part of the individual memory, as well as that of the group, is highlighted; where the desire to contribute to its development for the good of all arises [13]. Social recognition is manifested when the individual feels that he/she is a member of a community and capable of carrying out activities together, where the social sense is recognised in the measure of active concern for the other person, so that he/she can develop qualities and achieve common objectives [14].

On the other hand, the second category of study is based on the theory of sustainable development that emerged from the concept given by the Brundtland Commission in 1987, which managed to introduce the term sustainable development in the political and economic aspects. This development manages to meet the needs of the present, without depleting or affecting resources so that it can last over time and can provide the same benefit to future generations [15]. The theory of sustainable tourism, developed by the author Jost Krippendorf in 1977, points to an interdependence between tourism and nature, and refers to a new way of thinking that arose due to the secondary effects caused by the development of tourism-related activities in places where there is no planning that can guarantee a minimum impact. It integrates development at the economic level, without neglecting the social and cultural aspect, and also includes a commitment of developed countries together with developing countries to ensure compliance [16].

The theory of sustainability proposed for the development of tourism as a real and concrete objective, with environmental awareness and responsibility, which leads to



an improvement in social and economic levels, while promoting an appreciation of and respect for culture. Environmental conservation must become a key element in the competitiveness of tourist destinations [17].

The term sustainability of tourism was initially defined during the 41st Congress of the International Association of Scientific Experts in Tourism (AIEST), where the fundamental principles were given and it was stated that it preserves a balance between social, economic and ecological aspects, where activities are carried out for recreational purposes, but with the true aim of conserving cultural and natural values [18]. A few years later, the Charter for Sustainable Tourism defined that it should be ecologically sustainable over time for future generations, that it should generate economic development for the population and that it should promote equity, as well as respect for the culture of local communities [19]. This charter came about thanks to the initiative of the members and participants of the World Conference on Sustainable Tourism (WCTS), held on the island of Lanzarote as a result of the Rio Declaration, which is based on the care and preservation of the natural environment, as well as the economic development of the environment and local communities [20].

Due to the need to incorporate tourism that is environmentally responsible, respectful of local communities and a source of development for the place where this activity is carried out, sustainable tourism emerged as a tool that is capable of contributing to the reduction of people living in poverty, that is a key element in the protection of the environment and favours an increase in the quality of life of the locality. It also contributes to sustainable development as it is a tool that can be used by developing countries to generate economic income [21].

The importance of the sustainability of local tourism is reflected in the optimal performance of the activities of the tourism sector by reducing the impacts that can be generated in the performance of its actions, it can contribute to the consolidation of cultural identity and the preservation of the natural environment, including a revaluation of the local culture and its heritage. Thanks to this type of tourism, the local economy is diversified, increasing jobs and development for the community [22]. It is based on achieving a balance between the development of economic activity by the companies that form part of the tourism sector and the preservation of the natural state of the environment. It proposes as an alternative the care of biodiversity, respect for nature and the generation of responsible policies that prevent the negative effects produced by unplanned tourism, without alternative solutions to counteract these impacts [23].

The sub-categories of study are defined below:

In the environmental aspect, tourism activity must not generate damage in the place where it is developed, nor in the ecosystems that house the natural spaces; it must guarantee a controlled use of natural resources, in addition

to the care and protection of the flora, fauna and all the biodiversity that exists within the spaces where the tourism activity is going to be developed [24].

Economic development is of great importance for all sectors that form part of a country's development, especially tourism, since it is linked to the proper management of wealth. Socio-cultural development consists of the preservation of local authenticity, social integration and the capacity of local people to keep their cultural traits alive. There is a close relationship between the terms tourism and culture, referring to the fact that a sustainable model is intertwined with the preservation of the heritage and conservation of a given community, where aspects of planning and viable projection are employed [25].

### III. OBJECTIVES

The main objective of the study was to analyse the social and cultural values to achieve sustainability of local tourism in the province of Cañete in Peru, the specific objectives being: (i) To analyse the strengthening of collective memory to achieve sustainability of local tourism in the province of Cañete, (ii) To analyse the strengthening of sense of belonging to achieve sustainability of local tourism in the province of Cañete and (iii) To analyse the strengthening of social recognition to achieve sustainability of local tourism in the province of Cañete.

### IV. METHODOLOGY

The qualitative approach was developed, which focuses on understanding diverse phenomena through the study of the participants, their environment and the relationship between the two [26]. The inductive method and the case study design were used to obtain relevant information from the testimony of people knowledgeable about the subject [27].

The population consisted of 240,013 inhabitants of the province of Cañete, where six inhabitants and representatives of institutions involved in the development of local tourism were considered according to convenience sampling. The research used the interview technique and the semi-structured interview guide was applied as an instrument to guide the course of the interaction [28].

### V. RESULTS

The results obtained in the first category of social and cultural values are presented, where it was found through the development of the interviews that the situation of cultural identity in the province of Cañete is strengthened by the actions of the cultural representatives who show a sense of belonging to their place of origin and try to transmit the most representative cultural manifestations through festivities and local events that contribute to the economic, socio-cultural and environmental development of the province of Cañete, however, it is affected by various factors that limit the whole process and trigger a loss of identity among the younger population.

In the sub-category collective memory it was found that the province of Cañete has a series of cultural manifestations that are part of its collective memory such as festivities, ways of life, gastronomy, dances and ancestral traditions that have been transmitted from generation to generation by the oldest inhabitants of Cañete, but at present this memory is affected by a scarce diffusion of cultural and social values and it is necessary to take actions so that the youth do not continue losing the cultural elements that identify them.

With regard to the following sub-category, it was found that in the province of Cañete the sense of belonging is reflected in the actions of some representatives of the most relevant projects and in the work of certain inhabitants who want to see their locality develop and all its inhabitants have a better quality of life, which is why they are ready to continue encouraging and promoting the distinctive elements of Cañete's cultural identity so that real affective links can be created between the community and the construction of habitual meanings can be achieved.

It was identified that in the sub-category social recognition, the Cañeteños have a series of characteristics and cultural traits that define them, make them stand out and make them different from other communities. In general, the district is recognised for its cultural manifestations of religious and ancestral fervour, as well as the demonstrations of culture in various festivities that attract visitors and residents themselves.

In the category of sustainability of local tourism in the province of Cañete, work is being done little by little, since there are a series of factors that influence and limit the actions with respect to the improvement of the economic, socio-cultural and environmental sectors.

In the environmental sub-category, various resources and tourist attractions were found, including hills, beaches, valleys and rivers that have been affected by poor management of solid waste from the population and tourist activity, which affects the natural state and the ecosystems that exist within this territory. It is therefore important to take action to conserve these ecosystems and guarantee their permanence over time.

In the economic sub-category, it was found that the population of the province of Cañete stands out for being farmers, fishermen and traders; at present they are focusing on new areas such as the formation of restaurants and hotels, as well as the development of the transport sector and the increase of artisans that are consolidating as opportunities for the development of the local economy.

In the socio-cultural sub-category, it was found that the population of the province of Cañete is participating in the development process to a minimum degree, since there is no interest in culture, only in the improvement of their quality of life and economy, but their distinctive cultural traits continue to be forgotten and left aside. Policies for the protection of cultural rights are very necessary, in the

municipalities there is no budget for identity, they are only allocated on request, there is no budget for seminars, workshops, forums and lectures, there is a need for efficient management for the cultural development of the locality.

## VI. DISCUSSION

In the research there is a significant similarity with the research of Coronel Morán & Pino Barrantes (2019)[29] who concluded that in the Valley of the volcanoes in the province of Castilla in Arequipa many of the customs of the communities had ceased to be practised due to the low valuation of cultural identity, which is why their research has contributed to improving the appreciation of the natural space and cultural assets, so that the population becomes aware that the tourist attractions of the area are a fundamental part of strengthening rural tourism and therefore local development.

Currently, the situation of intangible assets has changed and they are in a state of disappearance due to factors such as the lack of participation of young people, including other important points such as the scarce financial resources for conservation, the depopulation of the place and cultural changes, which is why the declaration as intangible heritage is a good alternative together with the designation of laws for the preservation of cultural heritage that include strategic and economic planning, which will only have results if the population gives a real value to heritage.

The study by Fajardo-Herrera & Vargas-Prieto (2018)[30] agrees with the findings of the study, as in their research they concluded that peasants residing in the Peasant Reserve Zones of Colombia construct their identities and recognise themselves in relation to their territory and society, they also maintain an identity according to their ways of life and their agricultural work, they also consider themselves as a perfectly differentiated and diverse community that is part of society despite social stigmatisations. In addition Valencia Agudelo (2020)[31] who mentions that the social recognition of the actors of the territory of the Antioquian municipalities of Pueblorrico, Caicedo, Fredonia, Itagüí, Liborina and Concepción would not be possible without the conscious effort of the human groups of each of the municipalities to find their past, valuing and treating it with the respect it deserves, for this he adds that the participation of children, young people, students, teachers, community leaders and public officials is necessary as a fundamental element.

## VII. CONCLUSIONS

The following conclusions can be drawn from the research:

First: According to the general objective of the proposed research, the cultural and social values were analysed in order to contribute to the sustainability of tourism in the province of Cañete, finding the negative factors that are triggering the loss of the sense of belonging and identity among the younger population. For this reason, the problem is being addressed through the actions of cultural representatives who have taken the initiative to transmit

typical cultural manifestations through festivities and local events that contribute to the development and sustainability of the locality. Therefore, it can be synthesised that strengthening cultural and social values leads to the development of the province of Cañete, where it is essential the sum of efforts of public and private institutions and the commitment of the population; it is necessary that the cultural manifestations of Cañete are deepened, re-powered and revalued, being a decisive factor that the people of Cañete change their way of thinking so that they are able to protect and promote local tourism.

Second: According to the first specific objective of the research, the strengthening of the collective memory to contribute to the sustainability of tourism in the province of Cañete was analysed, where it was concluded that the cultural manifestations that form part of the collective memory of this locality have been transmitted from generation to generation by the oldest inhabitants of Cañete. However, the scarce dissemination of cultural identity has a negative influence on this process; therefore, it is necessary to take action so that young people do not continue to lose cultural elements. The research proposes the elaboration of a register of all these cultural elements, an arduous work of diffusion and joint work through workshops, talks, literary and bibliographical productions, works of art, among others, which are in charge of transmitting and maintaining through time, so that the youngest and the population in general acquire this knowledge and with this they can form part of the tourist projects promoted by the community, the municipality or other entities or associations.

Third: According to the second specific objective of the research, the strengthening of the sense of belonging was analysed in order to contribute to the development of sustainable tourism in the province of Cañete, where it was concluded that the sense of belonging is reflected in the actions of some representatives of the most relevant projects and in the work of a small group of inhabitants who want to see their district develop and all its inhabitants have a better quality of life, which is why they are ready to continue encouraging and promoting the distinctive elements of the cultural identity of the local population. This sense of belonging allows for the creation of links between the community and leads to the construction of meanings for a people, which is why it must be replicated throughout the population so that it can be expressed in joint actions that demonstrate the ties and bonds of love for the province, in order to favour the development and subsequent positioning of Asia as a tourist destination where customs are appreciated and valued.

Fourth: According to the third specific objective, the strengthening of social recognition was analysed in order to contribute to the sustainability of tourism in the province of Cañete, where it is concluded that social recognition is reflected in a series of characteristics and cultural features that define and highlight the Cañete inhabitants from other localities, as the district is recognised for being a land of farmers and fishermen where cultural manifestations of

religious and ancestral fervour are maintained, as well as demonstrations of culture in various festivities that attract local and foreign tourists. It is synthesised that the strengthening of the social recognition of the Cañete population needs to be worked on in greater depth so that the construction of the cultural identity of the inhabitants is maintained over time, the characteristics and cultural traits that define the Cañete population must be transmitted to children and young people because identity only exists if a group of people recognise it as part of themselves.

## REFERENCES

- [1] United Nations Educational, Scientific and Cultural Organization. (2020). ICH lists and the register of good safeguarding practices. <https://ich.unesco.org/es/listas>
- [2] Chamorro Lechón, L. N., & Maldonado Andramunio, Y. S. (2017). Cultural identity "causes that generate the loss of cultural identity of Imantag and its relationship with the development of tourism in Cotacachi Canton, province of Imbabura" [Undergraduate thesis, Universidad Técnica del Norte]. <http://repositorio.utn.edu.ec/handle/123456789/7964>.
- [3] Ministry of Culture. (2018). I National Survey: Perceptions and Attitudes on Cultural Diversity and Ethnic-Racial Discrimination. <https://centroderecursos.cultura.pe/site/s/default/files/rb/pdf/primeros-resultados-encuesta-discriminacion.pdf>.
- [4] Escudero Gonzalez, R. A., Trujillo Holguin, J. A., & Perez Piñon, F. A. (2019). Identity and culture: a journey to the Raramuri roots. *Revista Boletín Redipe*, 8(6), 174-184. <https://dialnet.unirioja.es/descarga/articulo/7528280.pdf>
- [5] Gimenez Montiel, G. (2005). Theory and analysis of culture. Cuidado Editorial. <http://ru.iis.sociales.unam.mx/jspui/handle/IIS/5035>.
- [6] Hall, S. (2010). Without guarantees: trajectories and problematics in cultural studies. (E. Restrepo, C. Walsh, & V. Vich, Edits.) Enviación Editores. [http://www.ramwan.net/restrepo/documentos/sin\\_garantias.pdf](http://www.ramwan.net/restrepo/documentos/sin_garantias.pdf)
- [7] Larraín, J. (1994). Latin American cultural identity: theory and history. *Estudios Públicos* (55), 31-64. [https://www.cepchile.cl/cep/site/docs/20160303/20160303184906/rev55\\_larrain.pdf](https://www.cepchile.cl/cep/site/docs/20160303/20160303184906/rev55_larrain.pdf)
- [8] Bákula Budge, C. (2000). Three definitions of heritage. *Tourism and Heritage* (1), 167-174. <http://ojs.revistaturismoypatrimonio.com/index.php/ty/article/view/102>
- [9] Molano, O. L. (2006). Cultural identity, one of the triggers of territorial development. RIMISP. [http://www.academia.edu/download/50523873/1854370848.identidad-cultural-uno-de-los-detonantes-del-desarrollo-territorial\\_PARA\\_REGIONAL.pdf](http://www.academia.edu/download/50523873/1854370848.identidad-cultural-uno-de-los-detonantes-del-desarrollo-territorial_PARA_REGIONAL.pdf)

- [10] Kogan, L., & Tubino, F. (2011). Identidades culturales y políticas de reconocimiento. Pontificia Universidad Católica del Perú. <https://red.pucp.edu.pe/ridei/files/2011/08/110302.pdf>
- [11] Cepeda Ortega, J. (2018). An approach to the concept of cultural identity from experiences: heritage and education. *Tabanque*, 31, 244-262. <https://doi.org/10.24197/trp.31.2018.244-262>
- [12] Ballesteros, C., Gracia, G., Ocaña, A., & Jácome, C. (2018). Analysis of cultural promotion as a tool to strengthen Afro-Emeraldean identity. *Revista Lasallista de Investigación*, 15(2), 367-377. <https://doi.org/10.22507/rli.v15n2a28>.
- [13] Bogoya Caviedes, G. E. (2017). The role of collective memory: an experience with women victims of the conflict in the municipality of Granada, Cundinamarca. *Ciudad Paz-ando Magazine*, 10(2), 29-39. <https://doi.org/10.14483/2422278X.12220>
- [14] Faundes Peñafiel, J. J. (2017). Honneth and the demand for intercultural recognition of indigenous peoples. *Latin American Profiles*, 25(49), 303-323. <https://doi.org/10.18504/pl2549-013-2017>
- [15] Vergara Tamayo, C. A., & Ortiz Motta, D. C. (2016). Sustainable development: approaches from the economic sciences. *Apuntes del Cenes*, 35(62), 15-52. <http://www.scielo.org.co/pdf/cenes/v35n62/v35n62a02.pdf>
- [16] Rivas, J. I. (2010). Sustainable or unsustainable tourism, that is the question: proxy indicators for environmentally responsible tourism planning. *Clm.economía* (15), 375-418. [http://www.clmeconomia.jccm.es/pdfclm/rivas\\_clm\\_15.pdf](http://www.clmeconomia.jccm.es/pdfclm/rivas_clm_15.pdf)
- [17] Salinas Chávez, E., & La O Osorio, J. A. (2006). Tourism and sustainability: from theory to practice in Cuba. *Cuadernos de Turismo*, (17), 201-221. <https://revistas.um.es/turismo/article/view/17931>
- [18] Cardoso Jiménez, C. (2006). Sustainable Tourism: an applied conceptual review. *El Periplo Sustentable* (11), 5-21. <http://hdl.handle.net/20.500.11799/40129>
- [19] World Conference on Sustainable Tourism. (1995). Charter for Sustainable Tourism. <http://sustainabletourismcharter2015.com/wp-content/uploads/2015/06/CharterForSustainableTourism.pdf>
- [20] Del Valle Pérez Colmenares, S. (2017). Planning and prevention of environmental impacts of tourism as a tool for sustainable development: Case study Timotes, Venezuela. *Interamerican Journal of Environment and Tourism*, 13(2), 164-183. <http://dx.doi.org/10.4067/S0718-235X2017000200164>
- [21] United Nations. (2014, 21 January). Resolution adopted by the General Assembly on 20 December 2013. <https://undocs.org/es/A/RES/68/207>
- [22] Jovanović, R., Sánchez, D. C., Pavlović, S., & Devedžić, M. (2018). Principles of sustainability in rural tourism clusters: the cases of the Upper and Lower Danube in Serbia. *Journal of Geography Great North*(70), 211-233. <http://dx.doi.org/10.4067/S0718-34022018000200211>.
- [23] Lalangui, J., Espinoza Carrión, C. R., & Pérez Espinoza, M. J. (2017). Sustainable tourism, a contribution to corporate social responsibility: Its beginnings, characteristics and development. *Universidad y Sociedad*, 9(1), 148-153. [http://scielo.sld.cu/scielo.php?script=sci\\_arttext&pid=S2218-36202017000100021&lng=es&nrm=iso](http://scielo.sld.cu/scielo.php?script=sci_arttext&pid=S2218-36202017000100021&lng=es&nrm=iso).
- [24] Alcívar Vera, I. I., & Bravo Acosta, O. M. (2017). Sustainable tourism: a community development alternative from a cultural component. *Espirales Revista Multidisciplinaria de investigación*, 1(9), 31-44. doi:10.31876/re.v1i9.114
- [25] Hernández-Sampieri, R. & Mendoza Torres, C. P. (2018). *Research Methodology: the quantitative, qualitative and mixed routes*. Mc Graw Hill Education. ISBN:978-1-4562-6096-5
- [26] Arispe A., C. M.; Yangali V., J. S; Guerrero B., M.E.; Lozada R., B. O; Acuña G., L.A. & Arellano S., C. (2020). *Scientific research. An approach to postgraduate studies*. Edit. UIDE, Guayaquil. <https://repositorio.uide.edu.ec/bitstream/37000/43101/LA%20INVESTIGACI%C3%93N%20CIENT%20%8DFICA.pdf>
- [27] Hernández Sampieri, R., Fernández Collado, C., & Baptista Lucio, M. P. (2014). *Research methodology*. Mc Graw Hill Education. <https://www.uca.ac.cr/wp-content/uploads/2017/10/Investigacion.pdf>
- [28] Arana Salazar, M., Lazo Serrano, L., & Bastidas, M. I. (2019). Intangible heritage of Zaruma parish: Study of perception of tourism potential and sense of belonging. *Revista Cumbres*, 5(2), 123-132. <https://investigacion.utmachala.edu.ec/revistas/index.php/Cumbres/article/view/436/15>
- [29] Fajardo-Herrera, K. N., & Vargas-Prieto, A. (2018). Social recognition in the post-conflict framework in Colombia: the case of peasant reserve zones. *Cooperativismo & Desarrollo*, 26(113), 1-16. <https://doi.org/10.16925/co.v26i113.2189>.
- [30] Valencia Agudelo, A. (2020). The recovery of the historical and cultural memory of small populations as a device for social, cultural and educational recognition. *Desbordes*, 11(2). <https://doi.org/10.22490/25394150.4384>



# Solar Energy Monitoring for IOT with fault Detection and Temperature Sensing Mechanism

<sup>[1]</sup> Sonali Laxman Dushing, <sup>[2]</sup> A.V.Naik

<sup>[1]</sup> M.Tech Student, Department of Electrical Electronics and Power, Jawaharlal Nehru Engineering College, Aurangabad, India

<sup>[2]</sup> Assistant Professor, Department of Electrical Electronics and Power, Jawaharlal Nehru Engineering College, Aurangabad, India

**Abstract**— The Internet of Things has a dream wherein the web reaches out into this present reality, which consolidates ordinary items. The IoT permits items to be detected or controlled distantly over existing system framework, making open doors for unadulterated combination of the physical world into PC based frameworks, and bringing about improved effectiveness, exactness and monetary advantage notwithstanding decreased human mediation. There is a different mix of vitality and every one of them are option in contrast to one another like sun oriented vitality, wind vitality, biofuel, power module, and so on. Be that as it may, the need of controlling of mixture vitality framework emerges when it is introduced for local or business purposes. Now, IoT assumes a significant job in controlling the framework. The principle rules are exchanging between the two wellsprings of vitality for example sun oriented and wind vitality with no bother through a site utilizing the ESP8266 Wi-Fi module. The information is communicated remotely through site to the ESP8266 module which controls the wellsprings of vitality. The communicated information is controlled distantly utilizing IoT. This empowers clients to have adaptable control instrument distantly through a made sure about web association. This framework causes the client to control the wellsprings of vitality, physically and distantly utilizing cell phone or PC. This framework is productive, less expensive and adaptable in activity.

**Keywords**— Solar Energy, Monitoring, IOT, Temperature sensing Mechanism

## I. INTRODUCTION

Client Sun based power plants ought to be checked for ideal power yield. This recoups capable power yield from power plants while checking for imperfect daylight based sheets, affiliations, and buildup accumulated on sheets cutting down yield and other such issues affecting sun situated execution. So here we propose an electronic IOT based sun fueled power registering structure that considers robotized daylight based power seeing from wherever over the web. We use ATmega regulator based structure to screen sun arranged board boundaries. Our structure consistently screens the sun arranged board and sends the power respect IOT system over the web. Here we use IOT Thingspeak to communicate sun based power boundaries over the web to IOT Thingspeak worker. It as of now shows these boundaries to the customer using a convincing GUI and besides alerts customer when the yield falls underneath unequivocal cutoff focuses. This makes distantly seeing of sun arranged plants incredibly basic and ensures best power yield.

The Internet of Things enables to hoard, eviscerate, and react upon the dew reason for data from things. Things or articles can be sensors or actuators. Contraptions are huge variety of devices along with daylight based watching, coronary heart checking embeds, electric, wearable, family motorization and vehicles with worked in sensors, or subject action devices that help smoke jumper in search for and give indications of progress undertakings. This sensor joined to devices will recoup the normal data for customer necessities. Sun situated imperativeness is the light that

shows up at the Earth; this daylight based essentialness is also called as sun based radiation. For example, having made sun radiation for an immense number of years by methods for nuclear blend, the power house conveys such a great deal of solidarity, that the proportion of sunlight that shows up at the earth in a single hour should meet the force needs of the absolute worldwide for an entire a year. Sun power is used to promptly change over to warmth water or space. On this framework, the power inside the kind of sun radiation is changed over into warm or heat power. Sun arranged force moreover can be changed over into power through photovoltaic or sun based force vegetation. This application describes, the depiction of the power from the daylight based sheets that can be checked distantly for instance The Internet of Things joins everything and licenses us to team up with our sheets. Using this we can: □ Create a channel and assemble boundaries from sun fueled sheets □ Analyze and Visualize boundaries. □ Act on the dew centers. The arrangement of enlightening records from the client for instance sun situated sheets by methods for the correspondence media through distant or wired medium. The data interpretation between the sheets and the addressed characteristics will be in the HTTP gathering. The sheets will be with unique sensor called center points, that social event of center points is confined packs where each gathering can contain cutoff of 25 centers and the of the center point information is sent to the entries where each gateway can contain cutoff of 5 bundles and that of each customer can contain cutoff of 100 passages. This assembled data will be addressed as the table that of where you can address the accumulated data record as the any truck structure and that of where all will be examined



educational list and of that will be fitting move will be made if any required.

The convergence of compelling far off shows, improved sensors, more affordable processors, and different new organizations and developed associations conveying the basic organization and application programming has finally arrived at the possibility of the Internet of Things standard. The driver of this accessibility is in a general sense the yearning to "incorporate regard" to things or organizations. These additional advantages from partner everything to the Internet are commonly fairly passed on between extended asset use, extended specialist benefit, better collaborations the chiefs, better client experiences, and extended R&D productivity[3]. The applications that appear, apparently, to be prime for IoT aggravation join home robotization, contraptions in light of everything, wearable handling devices, home social protection, retail and warehousing stock organization, related farms/agribusiness equipment, sun arranged imperativeness age and likely much more are so far being arranged. In aggregate, the IoT will make a few billions of dollars of new wages each year for telecom authority centers, semiconductor dealers, programming application traders, and item venders, and perhaps make huge bit of the pie cleanses, especially in end markets not used to the pace of planning based competitor.

IoT is one of the quickest making development designs, where a wide scope of devices and machines are related and "talk" to one another[7]. To come up to this issue, sun fueled imperativeness associations can get a handle on the Internet of Things, in any case called the Internet of Everything. Overall portrayed as the universe of more Internet-related endpoints arranged with machine-to-machine instinct, IoT can radically change essentialness associations, according to Cisco. For instance, a daylight based essentialness association can put in sensors on sheets to screen their execution and give constant information to site administrative groups. Sun fueled computerization can be depicted as introduction of structuring inside the sun arranged board condition to give convenience, comfort, security and imperativeness capability to its occupants [5]. Adding knowledge to sun based condition can offer extended individual fulfillment for the more established and incapacitated people who may some way or another or another require parental figures or institutional thought. With the entry of the Internet of Things, the investigation and execution of motorization are getting continuously notable [6]. XMPP, as of late known as Jabber, is a show at first proposed for use in messaging. Early IoT architects were excited about the XMPP considering its steady nature. It offers low dormancy correspondence back to a single, central worker. Exosite offers a XMPP-based API that was picked up for usage in applications where inaction is the most essential need. Regardless, XMPP has different issues that make it genuinely unacceptable for embedded IoT applications. As a XML-based show, XMPP is incredibly verbose, fundamentally more so than HTTP, and has overpowering data overhead. A single sales/answer

exchange to send one byte of data from a contraption to the worker is more than 0.5 kB. With the brisk improvement of IoT, new shows have been made unequivocally to fit the necessities of IoT systems and devices, including, the Message Queue Telemetry Transport (MQTT) show and the Constrained Application Protocol (top). These shows offer the upside of being expected to be capable and serious with such outstanding jobs that needs to be done found in IoT.

The same, they do fall behind in the areas of stage library sponsorship and general improvement of plan when diverged from the more settled shows. CoAP is another show that was starting late wrapped up by the Internet Engineering Task Force in update RFC 7252. CoAP was made courses of action for use with resource obliged embedded contraptions, both to the extent computation and system, while remaining altogether extensible. It was furthermore organized unequivocally to oblige issues that are most likely going to be knowledgeable about an overall IoT device fleet game plan. The semantics of CoAP were proposed to eagerly exhibit those of HTTP, so architects that are starting at now experienced with HTTP can locate a decent pace even more quickly, and applications made using HTTP can be immediately applied to applications using CoAP. In light of everything, as opposed to like HTTP, which is content based and uses TCP, CoAP is a matched show that is expanded UDP. Being a twofold show diminishes its data overhead, while its usage of UDP grows its versatility in correspondence models and its ability to reduce reaction times. This suggests coap isn't kept to just the semantics of HTTP. One of the benefits of using HTTP semantics over CoAP's UDP rather than HTTP's TCP is that a contraption can even more adequately utilize a comparative show code to speak with the cloud and various devices on the close by net. It can regardless partake in bundle correspondence with IP multicast.

As opposed to HTTP, CoAP is a nonconcurrent request/response show over a datagram arranged vehicle, for instance, UDP. The center/worker plan of HTTP is fairly phenomenal in CoAP as endpoints don't anticipate a so clear activity. The plan of coap is detached into two layers, a message layer responsible for trustworthiness and sequencing and a sales/response layer answerable for planning sales to responses and their semantics:

**Message layer:** The purpose behind the coap message layer is to control message exchanges over UDP between two end centers. Petitions and Responses share a normal message gathering. Messages are perceived by an ID applied to recognize duplicates and for faithful quality.

**Sales/Response layer:** CoAP requesting and response semantics are passed on in CoAP messages, which fuse either a procedure code or response code, separately. Optional (or default) requesting and response information, for instance, the URI and payload limit type are passed on as coap options. A Token Option is used to facilitate answers to requests self-governingly from the essential

messages. CoAP fundamental procedures: CoAP offers the techniques for a RESTful designing.

- 1) GET: Idempotent and safe system that recuperates a depiction of the information contrasting with the benefit perceived by the sales URI.
- 2) POST: Requests the planning of the depiction encased in the advantage perceived by the sales URI. Regularly it realizes another advantage or the thing resource being invigorated. The procedure is neither safe nor idempotent.
- 3) PUT: Requests that the benefit perceived by the sales URI be invigorated or made with the encased depiction. The depiction configuration is controlled by the media type given in the Content-Type Option. PUT isn't ensured, anyway idempotent.
- 4) DELETE: The procedure requests that the benefit perceived by the sales URI be eradicated. Responses are recognized by Response codes basically equal to HTTP Status codes. □ Caching and Proxying: The goal of putting away in application layer shows is to contract the vital framework move speed as a result of the reuse of prior response messages to satisfy a specific current requesting. In specific events, a put away response can be applied without including a web request, considering the constraints of LLNs, this exceptional focal points the lifetime, idleness and framework trips there and back.

CoAP URIs: CoAP URIs are essentially equivalent to HTTP URIs. The "coap" URI plot has been recognized for CoAP resources and for giving the best approach to discover the advantages. As in RESTful structures, resources are created continuously and spoken to by a potential reason worker tuning in for sales on a given port.

The most tremendous period of the item headway life cycle is System plan in which the outlining of the strategy on which the application must be run will be arranged and known. The basic thought of the system setup is the succinct sketch and answer for the essential file. The most basic fixing that bears on the idea of the item is perhaps structure of the arrangement. The fundamental purpose of the structure sort out is to develop the overall start of the item and its work cycle. Its fundamental job is to plot the modules that must be accessible in the structure to accomplish all of the necessities either gear or programming in a compelling style. From an overall perspective the structure will contain the specification of all of these modules, their participation with various modules and the ideal yield from each module, the completed consequence of the graph method is the depiction of the requirements programming designing.

## II. LITERATURE SURVEY

[1] Development of an electronic watching and control structure for spread Renewable Energy Sources (RES) taking into account Android stage. This method utilizes the Bluetooth interface of Android Tablet of Mobile phone, as

a correspondence associate for data exchange with cutting edge hardware of power Conditioning Unit.

[2] Introduction to a second watching establishment of reasonable force source age structure that is contained with a breeze turbine on current and voltage assessments of each boundless source .The related characteristics are assessed with the made distinguishing circuits and took care of by 18F4450 microcontroller of Microchip. The readied boundaries are then sent to (PC) over broad plan transport (USB) to be saved in information base and to watch the system instantly. The Coded visual interface of watching programming can manage the saved data to separate each day, step by step and month to month assessments of each assessment freely.

[3] Goto, Yoshihiro, explained about a fused structure that manages and distantly screens media transmission power plants has been made and has started exercises. The system is used to work and keep up more than 200,000 media transmission power plants which joins contraptions, for instance, rectifiers, inverters, UPS's and airconditioning plants presented in around 8000 structures. Feature of the structure are to consolidate the organization and far off registering limits with single system and improved UIs which uses information and correspondence development.

[4] Hottel e.l , The examinations had on the effects that causes to the sun arranged load up due earth the by without a doubt comprehended relationship on the planet google of 1.6 MW sun based plant in there California focal station. 4.7% ordinary disaster is recorded in the pioneer"s assessments by impact of buildup in the great bodies that is made by the makers. The makers Salim et al made an assessment on dust storing up and communicated that there is a 32% diminishing of sun based power in a scope of eight months in a sun situated town near Riyadh [5].

An assessment is driven by the makers Dirk Goosen et. Al in [6] on the sworn statement of the buildup particles which had affected the introduction of the PV cells and explored the airborne concentration and wind speed sway achieved by accumulation of buildup. Maker Garg of Roorkee made a preliminary and found that load up would diminish 8% typical conveyance by the social event of soil on 45-degree inclined glass plate following a 10-day time range [7]. As a result of social affair of buildup on the sheets it is seen that accommodating imperativeness is lessened by 30%. The standard systems used to clean the buildup is by sprinkling water on the sheets with cleaning administrator. Vibrating the sheets with motors as the telephone vibrates so the buildup goes off from the sheets. The buildup jumps off from the sheets by making a positive charge. By using a brush manual, we should clean the PV sheets. Sun arranged board checking is huge. It is central that sun based sheets are watched reliably by one way or another. You need to guarantee they are working precisely, and the system is delivering as much as envisioned. If you have sun based sheets presented, you should at any rate check the age meter once consistently and take a note of the scrutinizing [8].

Additionally, should go to the spot of the sheets sorted out and note the readings unavoidably. It is a manual checking procedure, reliably should go to the spot of daylight based board structure game-plan to note down the readings. Along these lines, it is past the domain of creative mind to hope to take readings continually, at whatever point required should go to the spot of structure course of action. Likewise, ideal power can't be obtained on account of no suitable game plan of sun fueled power.

**III. PROPOSED METHOD**

The rule objective of this assignment is to get an ideal power yield from the sun based sheets during dust is collected on it. Furthermore, if there is any separating of the sun fueled sheets will be appeared on and we can in like manner get information about whether the sun controlled or battery related for the stacks. The system recognizes and alerts the customer or the leader when is fall underneath the predefine conditions, and show on the GUI. A sun arranged board is used that keeps checking the sunshine. Here different boundaries like voltage, current and temperature are appeared on the LCD by using IOT development.

The basic objective of this endeavor is to get an ideal power yield from the daylight based sheets during dust is collected on it. Similarly, if there is any coming up short of the daylight put together sheets will be appeared with respect to and we can in like manner get information about whether the sun arranged or battery related for the piles. The structure recognizes and alerts the customer or the chief when is fall underneath the predefine conditions, and show on the GUI. A sun based board is used that keeps watching the sunlight. Here different boundaries like voltage, current and temperature are appeared on the LCD by using IOT development estimations.

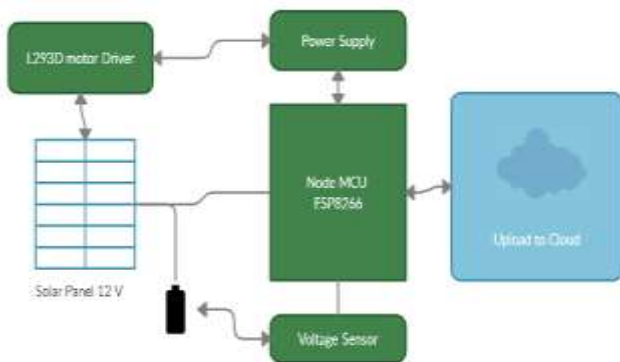

**Figure 1 Proposed Architecture**

There are two LDR sensor are put on sunlight based board, as daylight crash on LDR sensor, LDR sensor sense light and likewise dc engine turns thus greatest vitality is consumed by sun oriented board. After ingestion of daylight it sends towards sunlight based regulator and voltage and current are estimated by the sensors. This sensors perusing at that point sends towards the ADC this ADC changes over simple qualities into the computerized esteem and send to NodeMCU. NodeMCU is associated

with WiFi for web network. So the sensors perusing are send to cloud cut off where we can gauge the genuine perusing of voltage and current over cloud stage. In this innovation, we get more force from sun based vitality and we transferring to the IOT cloud utilizing Esp8266 we have utilized Thingspeak cloud to see the yield in diagram way likewise the sensor is utilized to quantify the force estimation of the sun powered plant.

**IV. SYSTEM SETUP**

Hardware Requirements-

- Node MCU ESP8266
- Voltage Sensor
- Solar panel
- DC motor and driver
- LDR sensor

Software Requirements

- Arduino IDE
- Embedded c

ESP8266 is a framework on chip (SOC) and Wi-Fi arrange that can convey programming applications. It additionally has TCP/IP convention that grants to get to Wi-Fi arrange. The ESP8266 is effective to have an application or eliminate all Wi-Fi organizing capacities from another application processor. The blaze memory can be begun straightly from an outer move. In-assembled store memory will help update framework execution and shorten memory prerequisites. Another condition is when remote Internet access considers the undertaking of Wi-Fi connector, you can coordinate it to any microcontroller-based structure, and the association is straightforward, just by SPI/SDIO interface. The module has awesome preparing and capacity ability. This permits it to incorporate by means of GPIO ports sensors and other application explicit machine with the most minimal advancement in ahead of schedule and least stacking during runtime. The ESP8266 permits less outer hardware because of the profoundly coordinated chip. It incorporates radio wire switch and front-end module, including the whole intended to limit PCB region. The arrangement of ESP8266 underpins the accompanying highlights: vitality sparing VoIP applications and Bluetooth impedance. It has selfgenerated RF permit it to take a shot at the working condition with no outside RF parts. The information voltage of the module is 3.3 V, with 8 pins, which have two pins of 1 TXD and 1 RXD, 2 GPIO pins for example GPIO 0 and GPIO 2, RST is Reset, VCC and GND is Ground. The module is modest and changing it into an IOT arrangement is a one of a kind thing [7].

**Voltage Regulator [AMS 1117-3.3]**

This is an adaptable and resolute voltage controllers are intended to give up to 1A yield current and is worked on 5V input. The dropout voltage of the gadget is ensured most



extreme 1.3V, diminishing at lower load flows. Force source hardware and controller in both to reduce the worry under over-burden circumstance to restrict current. Low current drop. It changes over 5V, 0.7A into 3.3 V for ESP8266 module. There are three pins,

- Ground
- Output (3.3 V)
- Input (5 V)

### Arduino IDE:

The program code written in Arduino IDE is known as a sketch. The Arduino IDE programming utilized for creating draws for ESP8266. This IDE contains the accompanying parts in it [9]:

- Text supervisor: This is the place the deciphered code can be composed utilizing a disentangled adaptation of C++ programming language.
- Message area: It shows blunder and furthermore gives a criticism on sparing and sending out the code.
- Text: The mitigate shows text yield by the Arduino condition alongside complete blunder messages and other data
- Console Toolbar: This toolbar envelop different catches like Verify, Upload, New, Open, Save and Serial Monitor. On the base right hand corner of the window there shows the Development Board and the Serial Port being used.

ESP8266-01 Wi-Fi module is utilized to interface with the web and it is connected to the site through which we can work our gracefully from anyplace on the planet. ESP8266 has 8 pins, which have two pins of 1 TXD and 1 RXD, 2 GPIO pins for example GPIO 0 and GPIO 2, Reset, VCC and Ground. TX and RX pins are utilized to streak the inserted code, in the wake of transferring the program into the module GPIO pins, Reset, VCC and Ground pins are utilized. There is no utilization of TX and RX subsequent to blazing, so it stays open. AMS1117 will gracefully 3.3V to the ESP8266 Wi-Fi module. Two GPIO pins are associated as a yield pin to the two ICs AP358 will accept it as an info. At the point when we give signal or select an alternative from site i.e., sunlight based on or wind on then from site a sign is sent through the web to the ESP8266 Wi-Fi module to turn ON sun oriented association or to turn ON wind association or to kill outside flexibly. The sign got from client will be controlled by the ESP8266 and it will give yield sign to the contribution of AP358. AP358 is the two-sided operation amp IC and used to control the gracefully, to shine the LED (load). It contains 8 pins VCC, Ground, 2-input collector, 2-set point pin and 2-yield. We are utilizing two of the different supplies to control LEDs. The sun oriented board is utilized as the force gracefully of one IC and dc generator (wind factory) is associated with another IC for power flexibly. Two PN-intersection diodes are utilized, which is associated with the yield of the AP358 IC. What's more, these diodes are associated with the LED.

Diodes are utilized, in light of the fact that when one gracefully is ON then another IC and their segment won't influence. Red LED is utilized. It is utilized as a heap. At the point when force flexibly is ON, ESP8266 is blue light will begin flickering and following couple of moments it is associated with the web. A site is utilized to control the gracefully of sun powered and wind. At the point when light is gone, at that point there are two kind of flexibly one is sunlight based and second is wind. We can work it from a site from anyplace on the planet.

Sun oriented force plants should be checked for ideal force yield. This recovers affordable force yield from power plants while looking for defective star boards, associations, soil collected on boards bringing down yield and diverse such issues moving star execution. thusly here we tend to propose machine-driven a programmed IOT based generally sun based vitality watching framework that empowers for mechanized sun oriented vitality viewing from wherever over the web. we tend to utilize Arduino based generally framework to watch a 10Watt sun oriented exhibit boundaries. Our framework ceaselessly screens the sunlight based exhibit and communicates the capacity yield to the IOT framework over the web. Here we tend to utilize IOT reptile to send sunlight based vitality boundaries over the web to the IOT reptile worker. It right now shows these boundaries to the client abuse a decent graphical UI and conjointly cautions clients once the yield falls beneath explicit cutoff points. This makes distantly watching of star plants awfully basic and ensures the best force yield.

The most prominent piece of a private sunlight based force framework is the sun powered boards. Slight film semiconductor or crystalline silicon is utilized make the P V sun powered cell for a large number of the private applications. These photovoltaic (PV) gadgets contain semiconductors that create power straightforwardly from daylight. The electrical gadgets are controlled, or it is send to the framework when electrons are made free by sun powered vitality in these materials. One of the most significant parts of getting your sun based boards to deliver electrical vitality at ideal productivity is keeping them in full and direct daylight. DC voltage current is produced when the Photovoltaic sun based boards are presented legitimately to the daylight. Sun powered boards produce the DC were the home apparatus chips away at the AC power, so the yield of the boards is given as contribution to the inverter. All the machine works through the inverter. The inverter comprises of a battery. The battery gets charges when the apparatus isn't in utilized and gets released when requires the inventory. Sunlight based checking frameworks will follow the measure of power your sun powered boards have produced and added to the force lattice.

For the detecting the light we have utilized a light needy resistor is segment shifts the obstruction with the light power that fall on it and can diverse a night and a day There are numerous potential methods for checking sun oriented boards. There are cutting edge arrangements which transfer

information ceaselessly to a web-based interface which permits you to screen your frameworks execution from anyplace on the planet. Right now we have an open source cloud[10] stage application think talk is utilized. Which recovers and stores the information from the sensor or the things associated with the frameworks through web that utilizations hypertext move convention (HTTP) from the nearby system to the cloud. It refreshes every one of the information logs got from the sensors, following area applications, and the status application providing for the clients and taken from the clients. To utilize this the client has make a record which contains various channels for observing of various parameters in the framework or in the checking the paraments in a remote gadget. This cloud empowers the executive or the client to picture the information in graphical portrayal. With web based checking, vitality yield information is moved to a switch, making it accessible through an online interface. The principle bit of leeway of frameworks like these is that your sunlight based board yield data is promptly accessible anyplace you can get a web association The hub MCU goes about as a key preparing component for the proposed framework as appeared in figure 4 and figure 5 which is created by ESP8266 open source network of smaller scale controller on single board that can be customized utilizing the Arduino IDE having a RAM size of 128Kbytes and program stockpiling limit of 4 Mega Bytes. It very well may be controlled by a USB link, having a working voltage of 3.3 to 5 volts and an in constructed Wi-Fi SoC Architecture.

## V. SOLAR PANEL

The power produced by catching the daylight is called as sun based vitality which is utilized for business and home reason. The normal atomic reactor is sun which discharges the vitality with modest bundles called photons. The molecules lose the electrons when the photons hit the sunlight based cells. A sun oriented board is made of different boards that wired together, greater power is created by the more boards we send. Silicon like semiconductors are utilized to make the PV photovoltaic sunlight based boards. Direct Current is produced by the sun powered boards. The vast majority of the electrical apparatus chips away at AC supply would ac be able to can be more affordable for transmit to long separations.

## VI. LIGHT DEPENDENT RESISTOR (LDR)

Photograph conductivity is the primary working rule of a LDR or light ward resistor. Every one of the electrons in the semiconductor of the valance band energizes when the light or photographs fall on the resistor. At the point when the light falls on the LDR opposition gets diminished and increment in obscurity or called as dim obstruction. Basing on the materials the LDR"s are grouped in to two sorts Intrinsic Photo Resistor and Extrinsic photograph resistor.

## VII. CLOUD TECHNOLOGY

An open source cloud stage application think talk is utilized. Which recovers and stores the information from the sensor or the things associated with the frameworks through web that utilizations hypertext move convention (HTTP) from the neighborhood system to the cloud. It refreshes every one of the information logs got from the sensors, following area applications, and the status application providing for the clients and taken from the clients. To utilize this the client has make a record which contains various channels for checking of various parameters in the framework or in the observing the parameters in a remote gadget. This cloud empowers the overseer or the client to envision the information in graphical portrayal. With web based checking, vitality yield information is moved to a switch, making it accessible through an online interface. The primary bit of leeway of frameworks like these is that your sun based board yield data is promptly accessible anyplace you can get a web association

## VIII. CONCLUSION

At this moment based system is planned to get an ideal power yield from the sun situated sheets during dust is gathered on it. Besides, a watching structure is expected for there is any falling flat of the sun put together sheets will be appeared with respect to and we can in like manner get information about whether the sun fueled or battery related for the loads. It at present shows these boundaries as appeared to the customer using an effective GUI and alerts customer when the yield falls underneath unequivocal purposes of repression. A sun based board is used that keeps watching the sunlight. Here different boundaries like voltage, current and temperature are appeared on the LCD by using IOT development. Directly we are getting just information we can see it in cloud anyway in future we can control whole structure through IoT which is a far off away.

## REFERENCES

- [1] P. Gopi Krishna et. al. "Design and development of bi-directional smart IoT gateway with interoperability for heterogeneous devices" International Journal of Engineering & Technology, 7 (2.8) (2018) 109-114
- [2] Nordrum, Amy (18 August 2016). "Popular Internet of Things Forecast of 50 Billion Devices by 2020 Is Outdated". IEEE
- [3] M. Moon. (2009) Google Studies How Dirt Affects Solar Panel Efficiency. PC Magazine: Good Clean Tech. Available: [www.goodcleantech.com/2009/08/google\\_studies\\_how\\_dirt\\_affect.php](http://www.goodcleantech.com/2009/08/google_studies_how_dirt_affect.php)
- [4] M. C. Hottel and B. B. Woertz, "Performance of flat plate solar heat collectors," ASME Trans., vol. 64, pp. 91-104, 1942.
- [5] Salim, F. Huraib, and N. Eugenio, " PV power-study of system options and optimization," in Proceedings



- of the 8th European PV Solar Energy Conference, Florence, Italy, 1988.
- [6] D. Goossens and E. V. Kerschaever, "Aeolian dust deposition on photovoltaic solar cells: the effects of wind velocity and airborne dust concentration on cell performance," *Solar Energy*, vol. 66, pp. 277-289, 1999.
- [7] H. P. Garg, "Effect of dirt on transparent covers in flat-plate solar energy collectors," *Solar Energy*, vol. 15, pp. 299-302, 1973
- [8] P. Gopi Krishna et. al. "Design and development of smart energy meter for effective use of electricity in IoT applications" *International Journal of Engineering & Technology*, 7 (2.8) (2018) 115-119
- [9] P. Gopi Krishna et. al "Design and development of bi-directional IoT gateway using ZigBee and Wi-Fi technologies with MQTT protocol" *International Journal of Engineering & Technology*, 7 (2.8) (2018) 125-129
- [10] Agora Energiewende (2016), "Agorameter", website, [www.agoraenergiewende.de/en/topics/-agothem-Produkt/produkt/76/Agorameter/](http://www.agoraenergiewende.de/en/topics/-agothem-Produkt/produkt/76/Agorameter/) (accessed 23 May 2016).
- [11] BNEF (Bloomberg New Energy Finance) (2016), Renewable Energy Projects dataset, Bloomberg New Energy Finance website, (accessed on 15 April 2016).
- [12] CENACE (2016), "Subastas Largo Plazo" [Long Term Auctions], website, [www.cenace.gob.mx/Paginas/Publicas/MercadoOperacion/Subastas LP.aspx](http://www.cenace.gob.mx/Paginas/Publicas/MercadoOperacion/Subastas LP.aspx). CSIR (Council for Scientific and Industrial Research) CSIR (2015), "Financial benefits of renewables in South Africa in 2015", CSIR Energy Centre, Council for Scientific and Industrial Research, Pretoria. CSIR (2016), "Wind and Solar PV Resource Aggregation Study for South Africa", CSIR Energy Centre, Council for Scientific and Industrial Research, Pretoria, [http://www.csir.co.za/Energy\\_Centre/wind\\_solarpv.html](http://www.csir.co.za/Energy_Centre/wind_solarpv.html).
- [14] DOE (2015), State of Renewable Energy in South Africa, Department of Energy, Pretoria, [www.gov.za/sites/www.gov.za/files/State%20of%20Renewable%20Energy%20in%20South%20Africa\\_s.pdf](http://www.gov.za/sites/www.gov.za/files/State%20of%20Renewable%20Energy%20in%20South%20Africa_s.pdf) (accessed 14 April 2016).
- [15] DOE (2011), "Integrated resource plan for electricity 2010-2030", Department of Energy, 25 March 2011. DEA (Department of Environmental Affairs) (2016), "Cabinet approves gazetting of Renewable Energy Development Zones", website, [www.environment.gov.za/mediarelease/cabinet\\_gazetting\\_redz](http://www.environment.gov.za/mediarelease/cabinet_gazetting_redz) (accessed 14 April 2016).
- [16] Efkem (2011), "Energy strategy 2050 - from coal, oil and gas to green energy", Danish Ministry of Climate and Energy on behalf of the Danish Government, Copenhagen, <http://www.efkm.dk/sites/kebmin.dk/files/news/from-coal-oil-andgas-togreenenergy/Energy%20Strategy%202050%20web.pdf> (accessed 13 May 2016).
- [17] Energinet.dk (2016), "New record-breaking year for Danish wind power", <http://energinet.dk/EN/El/Nyheder/Sider/Danskvindstroem-slaar-igen-rekord-42-procent.aspx>
- [18] IEA (International Energy Agency) (2016a), System Integration of Renewables: Implications for Electricity Security, OECD/IEA, Paris
- [19] IEA (2016b), RE-powering Markets: Market Design and Regulation during the Transition to lowCarbon Power Systems, OECD/IEA, Paris.
- [20] Shaik Razia, P.Swathi Pryathyusha, N.Vamsi Krishna "A Comparative study of machine learning algorithms on thyroid disease prediction" *International Journal of Engineering and Technology(UAE)*, ISSN No: 2227-524X, Vol No: 7, Issue No: 2.8, Page No: 315-319, March 2018.

# Virtual Reality (VR): A Review on its Application in Construction Safety

<sup>[1]</sup>Orlean G. DELA CRUZ, <sup>[2]</sup>Jobelle S. DAJAC

<sup>[1][2]</sup>Department of Civil Engineering, College of Engineering, Polytechnic University of Philippines, A. Mabini Campus, Anonas Street Sta. Mesa, Manila Philippines  
Email: <sup>[1]</sup>ogdelacruz@pup.edu.ph

**Abstract**— Technology has made workplaces safer and more effective. It has allowed us to increase efficiency, strengthen cooperation, and tackle more complex projects. Visualization technology application has established that simulated 3D site models have a strong ability to facilitate hazard identification and the cognition of worker's risk. Virtual Reality (VR) is one of the commonly recognized innovations that helps reduce the number of accidents in the workplace. Thus, this paper comprehensively discusses VR technology's role in construction safety achieved through a profound review of its applications, evolutions, and the challenges it imposes with its utilization. It is in line with the objectives of conducting an in-depth study of VR to address the knowledge gap that introduces these advanced technologies, such as providing sensitive information regarding its general concept, beneficial applications, and possible limitations. Like any technological advancement, the VR application still poses several challenges that are yet to be unraveled. Future study is expected to consider 1) inaccuracy between the user's actual movement and the virtual animation; 2) offering limited scope, therefore, overlooking other relevant factors; 3) work-intensiveness, relatively high cost and maintenance; and 4) technical complexity. Researchers recommended being considered for results are reviews based on their perspectives on its applications.

**Keywords**— Virtual Reality (VR), VR application; construction safety; safety management; review

## I. INTRODUCTION

The generally hazardous and unsafe environment that construction processes are usually immersed in [1], [2] makes its workforce safety one of the principal concerns worldwide [3]. And it indicated that compared to other occupational sectors, accidents in the construction industry take place to a higher degree, resulting in injuries, deaths, and revenue shortfall [4]. This claim was also supported by Wu and Fang, who further elaborated that this is a case experienced to a global extent [5]. Zhang et al. noted that the official database reveals that during the period between 1989 to 2013, over 26 000 workers assigned to construction jobs were reported to die under the site location [6]. Besides, the International Labor Organization (ILO) also said in 2005 that, considering worldwide records, the number of fatal incidents in construction sites reached approximately 60,000 cases annually [7]. Despite this alarming condition of construction safety worldwide, efforts in improving this subject were found to decrease since 1992, and that there is a "need for new and innovative safety practices" [8]. Correspondingly, it emphasized that even with the presence of rigorous safety and health protocols, "no significant decline in the number of construction accidents has been recorded" [9]. The same assertion was also reflected in Huang and Hinze (2006) statement, conveying that the construction industry's safety records remain one of the most unsatisfactory [10].

The construction industry is distinguished as a cynical sector for implementing advanced technologies in their regular practices [11], [12]. This hesitation is due to two primary reasons identified by Mitropoulos and Tatum

(2000): 1) ambiguity in the application of modern technologies and 2) inadequate knowledge and awareness of technology concepts and their benefits [13]. However, alongside the global impact of technologies on almost every aspect of living, researchers have gradually embraced technology's adoption to advance construction safety practices and amend existing safety programs through a profound and palpable evaluation of its domain [1]. Akinlolu et al. (2020) affirmed in a study that the application of broad and various technological innovations in on-site safety and health management had experienced a rap growth during the previous years. Numerous studies have been published concerning this timely and relevant subject, paving a broader path for boundless research opportunities [14]. Thus, as Zhou et al. and Li et al. argued, a review of these studies will be very significant for construction practitioners to thoroughly grasp and eventually integrate research potentials into their efforts in promoting safety and health management in the construction workplace [1], [2], [15].

One of these advancements that have been presently creating a highly regarded name is virtual reality (VR) technologies. VR, by definition, according to Steuer, is "a virtual system that consists of a computer capable of real-time animation, controlled through a group of equipment for simulating physical presence in places in the real world" [16]. Burdea and Coiffet (2003) also stated that VR could also engage its user's perception of sound, haptic, smell, and taste through computer interfaces that demonstrate real-time animation aside from the visual capabilities. Its attractive characteristics make it ideal for training applications in different fields, including medicine,

aviation, and the military. For instance, VR was used for surgery drills, combat training of soldiers, and flight exercising for pilots [17]–[19].

The succeeding sections of this paper comprehensively discuss the role of VR in construction safety achieved through a profound review of its applications, evolutions, and the challenges that it imposes with its utilization. It is in line with the objectives of conducting an in-depth study of VR to address the knowledge gap that introduces these advanced technologies, such as providing sensitive information regarding its general concept, beneficial applications, and possible limitations. Conveying the said information may also serve as guidelines for construction practitioners' consideration of implementing modern approaches to their regular safety procedures. Furthermore, this paper aims to present an inclusive evaluation of recent studies to discover new knowledge gaps to make way for more related and improved research topics.

II. METHODOLOGY

This section outlines a comprehensive analysis to discuss valuable observations into the existing construction safety literature and VR and identify future research's lack of knowledge. Keyword-based sources from electronic databases such as Scopus. The period studied ranges from 2010 to 2020, and the search was carried out using the "Title/Abstract/Keyword" field of the database, as mentioned earlier. The following keyword is "Virtual Reality" incorporated with another query search "construction safety," There where 69 documents identified through a database search, after removing duplicates, and by manually reading the abstract and parts of the entire articles considering the application of VR as a safety tool in construction safety, the number reduced to a total of 63 documents.

Using the Matlab text data analytics and applying a Latent Dirichlet Allocation (LDA), the abstracts were pre-processed. LDA is called a "topic model" since the defined word sets appear to represent the underlying topics that can be combined to describe each text in a corpus [20]. Topic modeling is a system used to model the search text as a mixture of subjects and each subject as a mixture of terms. The summary of the LDA topic results can be seen in Figure 1. The top four words in Topic 1 were as follows: environment, result, reality, training, application. This topic can be classified as training and application of Virtual Reality. Topic 2 comprised the following words: worker, hazard, construction, site, virtual. A topic can be classified as identifying hazards through visualization. For Topic 3 were: virtual, study, safety, construction. The subject can be classified as a study of virtual application in construction safety. Topic 4 with the following words: management, technology, safety, risk, research. It revealed there is potential research of VR technology in safety management.



Figure 1. Four (4) LDA topics generated through Matlab

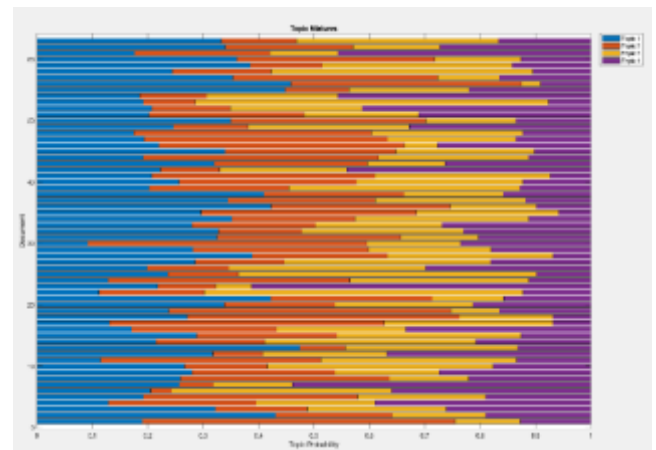

Figure 2. Topic mixtures generated through Matlab

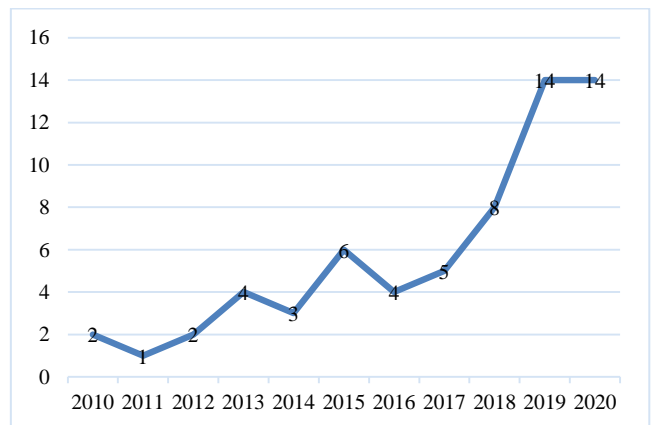

Figure 3. Number of papers published per year

As shown in Figure 2, the topic mixtures have been created using topics 1 to 4 with a different combination of topics that can be made. This graph is vital and used to create new topic VR-related topics and methods as a safety tool. Figure 3 shows the number of publications by year that suggested that the study of VR as a safety tool has improved.

### III. TRAINING AND APPLICATION OF VIRTUAL ENVIRONMENT

Firming up safety training and management is one of the most operative measures to successfully diminish safety accidents in construction sites [20]. Today's generation has gradually embraced the idea of virtual reality (VR) environments as one of the multiple technologies available for educational intents. The academe and construction works have been tested to efficiently benefit from this immersion, especially in retaining construction safety knowledge [21]. As shown in Table 1, twelve (12) studies out of the 66 publications retrieved from 1997 to 2017 related to the VR applications in Construction Engineering Education and Training (CEET) have been systematically reviewed and categorized under Construction Safety and Training [22]. The said frequency makes it the second-largest application area of VR in CEET, also reflected in a literature review conducted by Zhou et al. (2013). VR has been the most commonly applied advanced technology in promoting construction safety management [1].

According to Guo et al. (2012), VR offers several applications in the construction industry, including its innovative service as a 3-dimensional facility with interactive motions construction workforce's on-site safety management literacy [23]. With this, VR also effectively enables its users to take prudent precautions and proper approaches to different scenarios brought by the various hazards present in the construction site, as discussed by Wang, B. et al. (2014) [24]. The results of the study conducted by Jeelani et al. (2020) also recognized the efficiency of using an immersive training procedure for construction practitioners, stating that the said experience smoothed out the learning process for its users [25]. The said study also revealed that upon interviewing its participants, they acknowledged the "highly engaging and realistic experience" that they have undergone during the experimentation proper, which also instigated their responses during the training.

Several VR applications are materialized through research carried out. It is further elaborated on studies by categorizing as follows: preconstruction safety practices, safety training, education, hazard identification and assessment, situational awareness, and task compatibility [21]. Furthermore, these are the following specific VR applications, respectively:

Hadikusumo, 2002 and Rowlinson, 2004 explicitly developed a safety tool that adapted the knowledge of actual safety personnel for precautionary measures with the concept of VR as its backbone;

In 2011, Dickinson et al. then produced a "serious game," terminology used to distinguish the purposes of information and gaming technologies—either for entertainment or serious purposes (Sawyer and Rejeski, 2002). The serious game was used to educate construction trades students about trench and health safety. In fact, in a relevant study conducted by Pedro et al. (2016), it was reported that the

use of VR-based training demonstrated a much stronger effect on students' "understanding, knowledge, and grasp of safety concepts" compared to that of the paper-based training";

A VR environment program integrating Building Information Modeling (BIM) with 2-dimensional images was designed by Chen et al. (2013) to enhance the trainees' ability to identify potential hazards brought by different energy sources. Zhao et al. (2009) established a VE simulation-based training program to raise awareness of the construction site's electrical risks. Zhao and Ye (2012) also studied electrical hazards in construction sites and developed a 3D Online-Game Based Training for safety improvement in construction [26]. These studies can further justify the claim stated in the study of Goulding et al. (2012) that VR indeed primes construction workers and staff to "unforeseen problems that may occur due to various kinds of mismanagement on-site"; and Considering that construction projects differ in multiple ways and offer a wide range of hazardous possibilities, Li et al. (2012) altered an existing game engine to develop a multi-user virtual safety training program for tower crane dismantlement. It is further vindicated by Edirisinghe and Lingard's (2016) claim that "VR-based training demonstrated that it is a useful platform for tower crane operation (and iron laborer safety training)."

Realistic data gathered from real-life scenarios in construction sites were used by Mo et al. (2018) for their VR-based training experimentation, resting on the fact that using data-driven episodes is critical in the efficiency of using virtual reality for safety training [27]. Pena and Ragan (2017) also amassed construction accident reports provided by Occupational Health and Safety Administration (OSHA) and used these to develop a design of a virtual environment for construction and contextualize these through space, visuals, and texts [28]. In a study conducted by Cheng and Teizer (2013), it was also concluded that visualization technologies used in an ironworker training facility pose advantages which include enabling to record a replay of the implemented training, unbiased analysis of both safety and efficiency routine, an exhibition of the trainees' situational awareness, the study of the effectivity of trainee and trainer demonstrations in intricate and continuously changing construction procedures, and provision of a fascinating criticism from the training participants and trainees of future generations [29]. In 2018, Pham et al. developed an energy-efficient learning system (the interactive constructive safety education (eCSE)) using Web-based panoramic virtual photo reality technology for interactive construction safety education upon conducting a critical review of the literature and discovering the energy-consumption problems of conventional VR systems. Their study revealed that their developed eCSE system eliminates the limitations faced by traditional VR systems in terms of energy efficiency, adaptability with the trainee, more effortless execution, and improvement of learning usability [30].



Lucas et al. (2008) have also concisely pronounced the essential perks of the "cognitive learning" attained with the use of virtual reality training as compared to learning in the traditional methods performed in classrooms in the particular context of safety training for equipment operators [31]. This is also supported by a study on VR-based construction safety education system by Le et al. (2014), which stated that "collaborative VR has abundant potentials" in providing practical safety learning, as well as initiating joint efforts between trainees and improving their quality [32]. Concerning this, Getuli et al. (2020) also supported this claim, stating that by observing the scenario of those under the immersive VR simulation of the construction site for safety training purposes, a positive collaborative climate is nurtured amongst the trainees their interactions [33]. Vahdatikhaki et al. (2019) also concluded that using VR on safety training (context-realistic training simulators) can significantly improve safety learnings and teamwork, as well [34]. Meanwhile, Golovina et al. (2019) have pointed out several factors that should be considered to ensure the effectiveness and functionality of using VR tools for education and training purposes. Some of these include the test group's size, impact on existing construction routines, and human behavioral issues [35].

#### IV. IDENTIFYING HAZARDS THROUGH VIRTUAL APPLICATION

A study conducted by Azhar (2016) revealed that or 4-dimension dynamic tools perform a better function in safety planning and management in construction sites when compared to that of the 2-dimensional static drawings, mainly because of its ability to give the user an immediate impression of the real circumstances that happen on-site [36]. Furthermore, he also came up with the general conclusions that VR technologies provide the following: 1) a preview of the hazard possibilities along the construction process, thus enabling complementing mitigation; 2) identification of the activity sequence and materials needed before beginning the construction works, and 3) a rational recreation on the activity sequence during the carrying out of investigations regarding occupational accidents on the job site. Furthermore, in a study by Lucena and Saffaro (2020), it was concluded that the combination of virtual reality technology with the investigation protocol for the virtual world makes the detection of hazards effective. Virtual reality technology has been proven valuable in providing construction trainees with "visual stimuli," making it easy to intuitively notice dangerous situations. An essential function of the protocol used was to induce the user to systematically focus on the potential hazards, especially with less obvious dangers found in construction or any job sites [37].

Still eyeing safety in the construction industry, VR application is limited to on-site hazard identification, awareness, and the likes. It is also used even to the extent of the site's people's psychological and social aspects. Enumerated below are some of the studies which engaged

VR in exciting ways of analyzing construction safety practices:

Tixier et al. (2014) used a virtual environment in assessing the risk-taking behaviors of construction workers and staff, resting on the claim of various researches that it is one of the most significant factors in the majority of occupational accidents in the construction industry. The participants' emotional states were varied; then, they were exposed virtually to the hazards found on-site. Consequently, they measured perspectives on the risks that come with the dangers through questionnaires [38]. The same idea was proposed by Hasanzadeh et al. (2020), where the relationship of presence, mixed reality, and risk-taking behavior of the construction workers and the staff was analyzed using a VR environment (see Figure 1) [39];

An immersive VR environment was developed by Hasanzadeh et al. (2020) to explore the dormant effect of safety interventions (e.g., risk compensation). This study provides a preliminary understanding of how safety protections affect the risk-taking behavior of the subject, thus, giving ample ideas to the construction industry on how to wisely approach this issue towards the development of its safety practices [39];

VR was utilized by Habibnezhad et al. (2019) in their study regarding the factors that affect the postural stability of construction workers in the job site, especially when on elevated surfaces. It is rooted in the claim that falling from heights is one of the primary reasons for fatality and injuries at the construction site. The results of this study will be of significant contribution to the safety training of newly recruited workers to be subjected to heights [40];

Intending to test the effectiveness of VR technology utilization in safety training and simulations, Pinheiro et al. (2016) conducted a feasibility study of an eye-tracking technology that can analyze a construction worker's gazing patterns in his job site. The results will provide an understanding of how a worker perceives his environment and the presence of hazards [41]; and

A VR environment is used to evaluate the worker's field-of-view in alarm generation in a study conducted by Chan et al. (2020). According to their objectives, the proponents aim to provide "a fresh perspective to the growing adoption of wearable sensors by incorporating workers' awareness into the generation of hazard alarms." The study is presumed to lessen unnecessary alarm instigations, leading to better safety construction practices on-site [42].





**Figure 1. Experimental design by Hasanzadeh, S. et al. [39]**

In addition to these, VR was also utilized to develop an attribute-based risk analysis method to identify latent hazards in building models performed by designers and construction procedural coordinators [43]. This kind of technology has immersed trainees in a real-time visualization to effectively expand their understanding of an actual construction environment and identify the hazards that come along it [29]. Park and Kim (2012) also reckoned that through virtual reality functions, a worker could deduce the exact risks present in their job site [44], including those under the construction and engineering practices. It was also revealed in a study, upon experimentation, that their subject groups were able to identify more hazards appropriately with the use of virtual reality as compared with the set-up where photographs and documents were utilized [45]. In 2014, it instigated a study that became one of the first trials in producing a comprehensive training procedure to develop workers' hazard recognition skills and is the first attempt to measure the "impact of a human-centric augmented virtuality tool on adult learning" [4].

**V. A STUDY ON VIRTUAL APPLICATION IN CONSTRUCTION SAFETY**

The utilization of VR in the advancement of safety practices reaches the extent of health and safety managers' approval. It is used to review and possibly revise existing safety orders and form a "genuine health and safety work experience through virtual drills, instructions, and health and safety scenarios viable for construction health and safety training" [15], [46]. Shi et al. (2019) have also acknowledged the efficiency of using virtual reality in safety studies in a study they conducted regarding its performance as a tool for construction safety [47]. Table 2 summarizes the VR applications in construction safety in a 2015 state-of-the-art review conducted by Bhoir & Esmaeili. In the said table, the proponents, purpose, and benefits of utilizing VR as a tool in promoting on-site safety are located [21].

Similarly, Moore and Gheisari (2019) discussed their findings regarding VR-mixed reality systems' application objective for construction safety [48]. Four categories regarding the matter arose: hazard identification, hazard avoidance, hazard response and communication, and heavy equipment safety [48]. Some of the supporting researches

under the following categories mentioned, respectively include:

Panoramic photographs and videos were utilized by Jeelani et al. (2017) to develop a virtual training environment to enable its users to engross themselves in the scenario and then correctly identify the potential hazards present;

Cheng and Teizer (2013) earlier designed a VR program that involved both real-time tracking and the virtual representations of the workforce and equipment, which served as an image of on-site scenarios and aided their refraining from perilous areas;

In 2018, Shi et al. engaged with my multi-user system installed with motion-tracking facilities to "enhance iron-workers interpersonal social interaction and communication simulating their work in high-rise buildings" (see Figure 2) [49]. A relevant study by Shafiq and Afzal (2020) concluded that the utilization of VR could "reduce the language barriers in communicating job-site safety to such a multilingual industry," which can advance the promotion of proper safety performances in the community [50]; and

Fang et al. (2014, 2017, 2018) united real-time tracking and BIM ideas to produce a VR environment to train and practice safety measures literacy of crane operators.



**Figure 2. Views of the environment and motion capture system used in the experiment [49] (from left to right: real-world set-up, VR first-person view, VR perspective view)**

With the emergence of innovative technologies at present, acquiring research studies that reflect the applications of VR in improving the current status of construction safety has been straightforward. These research studies demonstrate VR's versatility and how it can be used in different ways to contribute to the on-site safety literacy and management of concerned individuals. For instance, Guo et al. (2012) developed a game-based interactive multi-client platform to serve as safety training for construction workers and staff. The said game presented a virtual environment—packed with real occupational hazards—where the trainees can experience a simulation that seems a lot like what truly happens to an actual site. The game also aims to empower the trainees' teamwork and communication while operating in the virtual environment [23]. Considering the accounted primary factors that instigate construction accidents, three core components were identified to form the conceptual framework that Guo et al. (2013) proposed to be followed when Virtual Prototyping: 1) modeling and simulation, 2) identification of unsafe factors, and 3) conduction of the safety training [51].

Concerning the construction safety awareness application of VR, a safety training and visualization system combines BIM, location tracking, augmented reality, and game technologies projected by Park and Kim (2013) [44]. Aside from offering an effective and vast safety practice and awareness knowledge using a mobile device, the system can also improve the laborers' real-time communication skills in a hazardous environment. Later in a 2015 study by Clevenger et al., it was reported after assessing the 3-dimensional visualization in safety training education in construction that the virtual construction safety training module integrated with BIM they established was "very effective for undergraduate students" [52]. In the same year, Sacks et al. made use of VR as a communication tool between designers and builders to "provide a forum for learning and proactive change of a design to make a project safer to build." The said study revealed that consultation and dialogues performed through virtual reality benefits designers' consideration of safety design in construction processes [53]. Côté and Beaulieu (2019) have also introduced a "VR Road and Construction Site Safety Conceptual Modeling Based on Hand Gestures," where an instinctual road plan VR application based on hand gestures was projected and established. The study demonstrated that the comfortable VR tooled applications they have developed presented a "natural, easy and fun to use" and can become a laid-back and user-friendly alternative for complex 3D engineering design software available (see Figure 3) [54].

Various VR applications were also enumerated by Zhou et al. (2013) in the literature review they conducted about the use of current innovative technologies in the improvement of on-site safety management [1]. VR was used in these, but are not limited to, the following applications:

Safety training in the process of steel erection (Irizarry and Abraham, 2005);

Permit the end-user in previewing a 3-dimensional project model for the preparation of design-for-safety-process (DFSP) and construction processes before actual construction is initiated (Rowlinson, 2000);

Identification of safety hazards during the design and construction phases, through assimilating VR construction model and DFSP database (Hadikusumo and Rowlinson, Rwamamara et al., Dawood et al., Zhang et al., 2002, 2010, 2012, 2012); and Establishing a 3-dimensional scenery model for safety monitoring in a tunnel construction (Oiu and Wan, 2010).



**Figure 3. Set-up showing the Leap Motion device affixed onto an HTC Vive VR headset (Left). Virtual hands (on-screen) positioned in VR in place of the real user's hands (Right) [54]**

## VI. POTENTIAL RESEARCH OF VR IN SAFETY MANAGEMENT

Being oriented about the numerous contributions of technology on a primary concern such as construction safety will create more impact and appreciation on every scholar's part. Despite being hesitant in fully implementing technology as a medium for different constructional activities [11], [12], Zhou et al. (2013) managed to discover a 1986 paper in the database they utilized regarding the use of expert system technology in construction safety management [1]. Since then and particularly the years before 1991, little to no studies were published until 2008. Furthermore, supposing that "research topics were closely associated with technology application," it asserted that technology-related studies also evolved through time, aiming to meet the needs for that specific period [1]. Keenly considering all their gathered literature, they came up with a quick summary of sample technological applications on construction safety through time, and it goes as follows:

Before 1995, studies mainly focused on cause analysis, hazard identification, safety assessment, and safety information;

Significance of designers on construction safety was apprehended, therefore developing the Design for Construction Safety Toolbox, which merged design ideas to construction safety (Gambatese et al.);

In 2000, Rowlinson used VR and 3D modeling to develop a design-for-safety-process (DFSP) used to assess safety risks on-site;

A geographic information system (GIS)-based decision support system was established for safety supervision in geotechnical construction (Cheng et al.);

Safety monitoring was the underlying focus of research from 2011 to 2012, widely introducing global positioning systems (GPS), sensor-based technology, 4-dimensional visualization technologies, VR, etc.

Meanwhile, Park et al. (2016) claimed that the application of visualization technologies such as VR had been long implemented for enhanced learning purposes, particularly in the CEET field, ever since the early 2000s [55]. Handful researches on that period have paved the way for gradual VR advancement. It was then believed that the VR environment could enable its users to have a real-time and interactive execution of desired approaches in a particular setting, giving a better intuition than traditional 2-dimensional graphics. However, it was not until 2013 that the number of publications focusing on VR applications in CEET has increased (see Figure 1). Among that wave on VR-related publications are the studies conducted by Cheng and Teizer (2017) and Park and Kim (2013). A location tracking and data visualization technology as a medium for ironworkers' construction safety education and training and a framework for construction safety management and

visualization system aimed to level up workers' knowledge about proper safety practices [29], [44].

Generally speaking, the studies on applying these visualization technologies were discovered to demonstrate positive effects in construction safety education and training, whether for the formal or informal environment [36]. Due to its rising status, the use of these innovations led to "a demand for a thorough review of the state-of-the-art of these developments" [56]. Some applications of VR in construction safety and risk management have encompassed a wide range of variety after several years since its emergence.

Observing and comparing all the gathered recent research studies presented in Table 1 to what has been previously discussed on VR's evolutions demonstrates that its application in construction safety management has come a

long and broader way. Aside from the traditional focus of testing VR's capability of engaging workers to a better learning experience, most of these innovative studies have started integrating the field of psychology. Also, it comprises social aspects to develop a more profound and more complicated method for evaluating how construction safety is generally perceived. Recent VR evolutions not mentioned in the previous discussions are also noted, including the concept of V-REP. These vast steps of amplifying VR applications eventually offered new and significant information that will contribute to the industry's development, especially in terms of safety and risk management. With that, Table 1 reflects the researches' specific application on construction safety and the specified contributions and advantages of VR utilization in the study, respectively. Most of the contents of the said table directly came from ideas observed in the actual research paper.

**Table 1. VR Application in Construction Safety, its Contribution, and Advantages**

Citation	Advantages	Application in Construction Safety
[38]–[40], [42], [49], [57], [58]	<p>Exposing the test subjects to the VR applied made their responsive behaviors realistic and more natural.</p> <hr/> <p>VR overcame the limitation brought by the difficulty of simulating hazardous scenarios that happen in real life.</p> <hr/> <p>It also allowed participants to experience unsafe situations without being exposed to actual risk.</p>	Understanding of workforce well-being and tendencies
[59]	This study is highly influenced by improving the VR environment's "interactive conflicts visualization and dynamical construction safety simulation."	Hazard identification
[41], [50]	The utilization of VR technologies immersed participants in a real-time condition that produced almost entirely accurate responses in the experiment.	<p>Identification of the workforce's limitation and preferences</p> <hr/> <p>Identification workforce's Safety monitoring</p>

Four particular applications of VR in construction safety were determined upon reviewing the literature. They are listed below and selected by perceiving the research's significance and results with a brief explanation.

*Understanding of workforce well-being and tendencies.* The majority of the ten types of research fell under this application. As previously discussed, VR technologies as a medium to integrate sociology and psychology into construction safety have attracted much attention from different researchers in recent years. These include attempts to study the construction workforce's behaviors to determine other platforms that may improve the current status of their on-site safety literacy. The research under this category focused on the workers themselves—specifically on how they usually act on and perceive the risks around them during work hours—to contribute ideas regarding the most effective safety training and education methods to be implemented. For instance, Hasanzadeh et al. (2020) stated that the findings of the research they conducted could have a significant impact on "how the construction industry approaches the development and implementation of safety interventions to offset the

influence of risk compensation" [39]. Earlier, Habibnezhad et al. (2019) also asserted that their experiment results could be valuable to the training programs for rookie ironworkers to be laid open to extreme height and or steel erections. Meanwhile, these researches also share the same advantages of acquiring VR[40], as shown in Table 1.

*Hazard identification.* VR's influence was so high that it also uproots several innovative research ideas, including Shang and Shen's (2016) study [59]. A safety assessment model developed through a 4D BIM-enabled environment can be integrated into virtual environments for better experience and impact. Specifically, this model comprises three distinct features: 3D workspace representation, spatial-temporal conflicts detection, and 4D site safety analysis. These fall under hazard identification, a proactive procedure to mitigate the risks on-site during the actual work hours.

*Identification of the workforce's limitations and preferences.* VR technologies were also used to obtain actual recommendations from the construction workforce themselves. Considering Shafiq and Afzal's (2020) study,



surveys were conducted to identify factors that affect the workers' considerations in applying VR to their regular construction safety programs [51]. Immersing them in VR personally made them process the experience better and therefore come up with honest realizations. On the other hand, the experiment conducted by Pinheiro et al. (2016) also targeted to analyze the laborers' preferences on what to look either or overlook on-site through their visual patterns, which brings this discussion to the last application, which is safety monitoring [41].

*Safety monitoring.* The study of Pinheiro et al. utilized an eye-tracking technology that also tests VR's effectiveness on safety training and programs since VR is a direct application of the former. The in-depth analysis of workers' perception of the site, according to the proponents, "can determine the understanding level of safety requirements and guidelines adopted by a company or even indicate layout problems in the construction site planning." Through this type of study, the higher authorities can regularly keep an eye on what safety factors should need attention and apply proper actions to lessen their impact.

## VII. THE CHALLENGES OF VIRTUAL REALITY (VR) IN CONSTRUCTION SAFETY

Taking all applications and evolutions of VR in construction safety into account, it is fair to infer that VR's utilization can significantly improve the current safety platforms that construction companies immerse their workforce. According to Azhar (2016), the VR environment can offer relevant information that professionals (i.e., designers, engineers, and contractors) can apply to implement more effective procedures to mitigate or even eradicate inevitable construction hazards and risks [36]. Lin et al. (2011) also stated that scholars have confidence in VR's capability as a tool to address the difficulties that the construction industry faces regarding their campaign on proper safety practices [60]. However, being a relatively new instrument, VR application in construction safety still raises many challenges despite its numerous impressive uses. Garbaya and Zaldivar-Colado (2017) also noted that developing VR environments can generally be demanding "due to the complexity and limitations associated with these" [61].

Bhoir and Esmaili (2015) indicated in a study that contrary to what most researchers claim on VR's advantages, practitioners' preference remains committed to hands-on safety training rather than VR-based [21]. Their research revealed that only 7% of their respondents—the majority of which are safety training professionals with an average of 13 years of experience—might opt to apply VR environment-based platforms on their safety training. None of these respondents also use VR environments in their safety training and methods. Besides, Hatem et al. (2018) suggested that older employees, which do safety practices inclined to the traditional techniques, hinder the industry's open-mindedness applying technological advents in their regular training [62]. It was also disclosed that "high set-

up, implementation, and maintenance costs" are also considered barriers in adapting visualization technologies to improve safety on-site and the unfamiliarity on the return that investment on VR technologies can produce [38]. It is also in line with the study's findings by Azhar (2017). Accordingly, it pointed out that utilizing these tools requires an additional budget from the industry for its development and implementation. He then added safety and health personnel's inadequate knowledge about these tools and technical matters (i.e., "non-availability of safety elements and equipment" in the VR software database) as identified challenges in using VR. This claim is also supported by the study's findings by Bhoir and Esmaili (2015), where it was revealed that "construction workers usually lack specialized computer knowledge." Their paper also indicated that skills needed for enhancing VR applications are seldom found, even among the engineering community. Aside from these, the optical risk is also raised as a barrier in thoroughly applying VR in construction safety since, as Clarke et al. (2016), stated long exposure and immersion in VR environments could cause dizziness [63].

Focusing more on the scope of the reviewing in this paper, presented below are the experimental research and the specific challenge imposed by their VR application in the study. The content of the challenges may or may not be directly derived from the paper itself but is conveyed through objective interpretations.

**Table 2. Challenges imposed by Virtual Reality**

Citation	Challenges
[38]	Partial control over the user's approach in moving in the VR environment
[49]	Inaccuracy between the user's actual movement and the virtual animation
[28], [45], [58]	Inaccuracy between real-time and virtual animation
[42], [59]	May offer limited scope overlooking other relevant factors
[35], [39], [42], [53], [64]–[66]	Work-intensive: "High set-up, implementation, and maintenance costs" (Shafiq & Afzal, 2020)
[57]	Subjective measuring tool
[40]	"Lack of peripheral visual inputs while wearing glasses." (Streepey et al., 2007)
[50]	Unawareness of the return on investment for VR utilization and its concept (Shafiq & Afzal, 2020)
[29], [41]	Technical complexity

VR has been revealed to be the most frequently applied advanced technology in terms of construction safety and risk management [1]. Since its emergence during the early 2000s [55], it has evolved to different kinds that meet various purposes under other circumstances (i.e., SAVES, Multi-user VR, CAVE, VDC tools, V-REP, etc.). In the

previous section of this paper, loads of studies focusing on VR's feasibility as a tool to further understand and evaluate on-site safety are enumerated. Wang et al. (2018) also pointed out VR's provision of an "engaging and immersive environment" made it an ideal medium for site safety-related experiments [22]. It was also demonstrated that the significant advantage of VR utilization is its capability to surmount the limitation brought by the difficulty of simulating hazardous scenarios. It happens in real life by enabling its users to "experience" unsafe procedures without being exposed to actual risk.

Some of the general applications of VR that are mutually found between researchers ever since the growth of its number gradually increased are 1) hazard identification, 2) hazard avoidance, 3) hazard response and communication, and 4) heavy equipment safety [48]. However, recent studies have also integrated VR environments to more complex fields like psychology and social influence. As shown in this paper, VR's application has also now encompassed the 1) understanding of workforce well-being and tendencies, and 2) identifying its limitations and preferences. These studies revealed significant findings, which intimately involved principles from the very core of progression on-site—its workforce, that can produce ideal measures and amendments to enhance the status quo of construction safety and risk management. Nonetheless, just like any technological advancement, VR application still poses several challenges that are yet to be unraveled. Some of these, as discussed above, include the following challenges cited by more than one study: 1) inaccuracy between the user's actual movement and the virtual animation; 2) offering of limited scope, therefore, overlooking other relevant factors; 3) work-intensiveness, relatively high cost and maintenance; and 4) technical complexity.

### VIII. CONCLUSION

Visualization technologies, particularly virtual reality, have progressed with time. As VR emerged into different types, it also entered a broader range of applications that paved the way for a more complex assessment of the current construction safety training platforms. Gathering the related literature on the role of VR in on-site safety management has offered a handful of information about its applications, evolutions, and challenges that can be generalized to develop an improved way of conveying the proper drills measures to the construction workforce.

Several gaps have been examined to further research endeavors on contributing to construction safety practices. First, it was observed that most researchers did not consider the financial background of utilizing VR, which is a relatively new tool, still unaccustomed. As an industry, construction companies must acknowledge the monetary aspect of implementing new programs [1]; therefore, it is appropriate to discuss this aspect to up the chances of this research to be considered. Second, it was also discerned that many of the researchers claimed that the study they

have undertaken would help identify improvement points in on-site safety training. The researchers' focus is more on determining the appropriate technologies to amend a particular scenario [1], [67]. Not much about discussing a specific idea of applying the findings on real-time construction safety programs were noted. Some of the studies [38], [39], [41], [49], [68] also did not use actual construction workers for their experiment proper. Therefore, research that intimately inclines to a realistic construction set-up achieved through VR and involving people from the industry itself is crucial and will bear more accurate results. Lastly, while recent studies have focused on the workforce's behaviors, it is also equally important to give attention to the higher practitioners' dispositions (i.e., engineers and contractors) on the idea of VR as a construction safety training tool. As we all know, they are the ones who need elaborating convincing on the claim that this innovative medium is worth their time and budget. It is recommended that studies based on their perspectives on VR applications should also be considered for results. This way, other research opportunities intended to meet their expectations and standards may again emerge.

### ACKNOWLEDGMENT

The Authors would like to express the most profound appreciation to PUP Engineering Science Department Family, namely; Juland A. Padilla, Kristel D. Lopez, Christian A. Mendoza and John Pual J. Pauya, without their support, the completion of this research would not have been possible.

### REFERENCES

- [1] Z. Zhou, J. Irizarry, and Q. Li, "Applying advanced technology to improve safety management in the construction industry: a literature review," *Construction Management and Economics*, vol. 31, no. 6, pp. 606–622, Jun. 2013, doi: 10.1080/01446193.2013.798423.
- [2] W. Zhou, J. Whyte, and R. Sacks, "Construction safety and digital design: A review," in *Automation in Construction*, Mar. 2012, vol. 22, pp. 102–111, doi: 10.1016/j.autcon.2011.07.005.
- [3] M. Kassem, L. Benomran, and J. Teizer, "Virtual environments for safety learning in construction and engineering: seeking evidence and identifying gaps for future research," *Visualization in Engineering*, vol. 5, no. 1. Springer, Dec. 01, 2017, doi: 10.1186/s40327-017-0054-1.
- [4] A. Albert, M. R. Hallowell, B. Kleiner, A. Chen, and M. Golparvar-Fard, "Enhancing Construction Hazard Recognition with High-Fidelity Augmented Virtuality," *Journal of Construction Engineering and Management*, vol. 140, no. 7, p. 04014024, Jul. 2014, doi: 10.1061/(asce)co.1943-7862.0000860.
- [5] D. Fang and H. Wu, "Safety Culture in Construction Projects," 2012.
- [6] S. Zhang, J. Teizer, J. K. Lee, C. M. Eastman, and M. Venugopal, "Building Information Modeling (BIM)



- and Safety: Automatic Safety Checking of Construction Models and Schedules,” *Automation in Construction*, vol. 29, pp. 183–195, Jan. 2013, doi: 10.1016/j.autcon.2012.05.006.
- [7] FACTS ON Safety at Work.” [Online]. Available: www.ilo.org/safework.
- [8] M. Hallowell, B. Esmaili, and P. Chinowsky, “Safety risk interactions among highway construction work tasks,” *Construction Management and Economics*, vol. 29, no. 4, pp. 417–429, Apr. 2011, doi: 10.1080/01446193.2011.552512.
- [9] N. Azmy and A. Z. M. Zain, “The Application of Technology in Enhancing Safety and Health Aspects on Malaysian Construction Projects,” *ARPJ Journal of Engineering and Applied Science*, vol. 11, no. 11, pp. 7209–7213, 2016.
- [10] X. Huang and J. Hinze, “Owner’s Role in Construction Safety,” *Journal of Construction Engineering and Management*, vol. 132, no. 2, 2006, doi: 10.1061/ASCE0733-93642006132:2164.
- [11] P. Gonzalez de Santos, J. Estremera, E. Garcia, and M. Armada, “Power assist devices for installing plaster panels in construction,” *Automation in Construction*, vol. 17, no. 4, pp. 459–466, May 2008, doi: 10.1016/j.autcon.2007.08.006.
- [12] J. Andresen *et al.*, “A Framework for Measuring IT Innovation Benefits,” *ITCon*, vol. 5, pp. 57–72, 2000.
- [13] P. Mitropoulos and C. B. Tatum, “Forces Driving Adoption of New Information Technologies,” *Journal of Construction Engineering and Management*, vol. 126, no. 5, pp. 340–348, 2000, doi: 10.1061/(ASCE)0733-9364(2000)126:5(340).
- [14] M. Akinlolu, T. C. Haupt, D. J. Edwards, and F. Simpeh, “A bibliometric review of the status and emerging research trends in construction safety management technologies,” *International Journal of Construction Management*, 2020, doi: 10.1080/15623599.2020.1819584.
- [15] R. Yi, M. Li, and T. H. Leung, “Leading safety indicators and automated tools in the construction industry,” *Proceedings of the 34th International Symposium on Automation and Robotics in Construction*, 2017, doi: 10.22260/isarc2017/0106.
- [16] J. Steuer, “Defining Virtual Reality: Dimensions Determining Telepresence,” *Journal of Communication*, vol. 42, no. 4, pp. 73–93, 1992, doi: 10.1111/j.1460-2466.1992.tb00812.x.
- [17] U. Kühnapfel, H. K. Çakmak, and H. Maaß, “Dynamic Medical Visualization Endoscopic surgery training using virtual reality and deformable tissue simulation,” *Computers & Graphics*, vol. 24, no. 5, pp. 671–682, 2000, doi: 10.1016/S0097-8493(00)00070-4.
- [18] J. Vora, S. Nair, A. K. Gramopadhye, A. T. Duchowski, B. J. Melloy, and B. Kanki, “Using virtual reality technology for aircraft visual inspection training: presence and comparison studies,” *Applied Ergonomics*, vol. 33, no. 6, pp. 559–570, 2002, doi: 10.1016/S0003-6870(02)00039-X.
- [19] M. Macedonia, “Games Soldiers Play,” *IEEE Spectrum*, vol. 39, no. 3, pp. 32–37, 2002, doi: 10.1109/6.988702.
- [20] D. M. Blei, A. Y. Ng, and J. B. Edu, “Latent Dirichlet Allocation Michael I. Jordan,” 2003.
- [21] S. Bhoir, B. Esmaili, and P. D. Student, “State-of-the-Art Review of Virtual Reality Environment Applications in Construction Safety,” *Proceedings of the AEI Conference 2015*, 2015, doi: 10.1061/9780784479070.040.
- [22] P. Wang, P. Wu, J. Wang, H. L. Chi, and X. Wang, “A critical review of the use of virtual reality in construction engineering education and training,” *International Journal of Environmental Research and Public Health*, vol. 15, no. 6. MDPI AG, Jun. 08, 2018, doi: 10.3390/ijerph15061204.
- [23] H. Guo, H. Li, G. Chan, and M. Skitmore, “Using game technologies to improve the safety of construction plant operations,” *Accident Analysis and Prevention*, vol. 48, pp. 204–213, Sep. 2012, doi: 10.1016/j.aap.2011.06.002.
- [24] B. Wang, H. Li, Y. Rezugui, A. Bradley, and H. N. Ong, “BIM based virtual environment for fire emergency evacuation,” *Scientific World Journal*, vol. 2014, Jan. 2014, doi: 10.1155/2014/589016.
- [25] I. Jeelani, K. Han, and A. Albert, “Development of virtual reality and stereo-panoramic environments for construction safety training,” *Engineering, Construction and Architectural Management*, vol. 27, no. 8, pp. 1853–1876, Apr. 2020, doi: 10.1108/ECAM-07-2019-0391.
- [26] D. Zhao and Y. Ye, “Using Virtual Environments Simulation to Improve Construction Safety: An Application of 3D Online-Game Based Training,” *Future Control and Automation. Lecture Notes in Electrical Engineering*, vol. 172, pp. 267–277, 2012, doi: 10.1007/978-3-642-31006-5\_33.
- [27] Y. Mo, D. Zhao, J. Du, W. Liu, and A. Dhara, “Data-Driven Approach to Scenario Determination for VR-Based Construction Safety Training,” *Construction Research Congress*, 2018, doi: 10.1061/9780784481288.012.
- [28] A. Peña and E. Ragan, “Contextualizing Construction Accident Reports in Virtual Environments for Safety Education,” *2017 IEEE Virtual Reality (VR)*, pp. 389–390, 2017, doi: 10.1109/VR.2017.7892340.
- [29] T. Cheng and J. Teizer, “Real-time resource location data collection and visualization technology for construction safety and activity monitoring applications,” *Automation in Construction*, vol. 34, pp. 3–15, 2013, doi: 10.1016/j.autcon.2012.10.017.
- [30] H. C. Pham, N. N. Dao, J. U. Kim, S. Cho, and C. S. Park, “Energy-efficient learning system using Web-based panoramic virtual photoreality for interactive construction safety education,” *Sustainability*

- (Switzerland), vol. 10, no. 7, Jul. 2018, doi: 10.3390/su10072262.
- [31] J. Lucas, W. Thabet, and P. Worlikar, "A VR-Based Training Program for Conveyor Belt Safety," *Journal of Information Technology in Construction*, vol. 13, pp. 381–407, 2008.
- [32] Q. T. Le, A. Pedro, and C. S. Park, "A Social Virtual Reality Based Construction Safety Education System for Experiential Learning," *Journal of Intelligent and Robotic Systems: Theory and Applications*, vol. 79, no. 3–4, pp. 487–506, Aug. 2015, doi: 10.1007/s10846-014-0112-z.
- [33] V. Getuli, P. Capone, and A. Bruttini, "Planning, management and administration of HS contents with BIM and VR in construction: an implementation protocol," *Engineering, Construction and Architectural Management*, 2020, doi: 10.1108/ECAM-11-2019-0647.
- [34] F. Vahdatikhaki, K. el Ammari, A. K. Langroodi, S. Miller, A. Hammad, and A. Doree, "Beyond data visualization: A context-realistic construction equipment training simulators," *Automation in Construction*, vol. 106, Oct. 2019, doi: 10.1016/j.autcon.2019.102853.
- [35] O. Golovina, C. Kazanci, J. Teizer, and M. König, "Using Serious Games in Virtual Reality for Automated Close Call and Contact Collision Analysis in Construction Safety."
- [36] S. Azhar, "Role of Visualization Technologies in Safety Planning and Management at Construction Jobsites," in *Procedia Engineering*, 2017, vol. 171, pp. 215–226, doi: 10.1016/j.proeng.2017.01.329.
- [37] A. F. E. Lucena and F. A. Saffaro, "Guidelines for exploring construction sites in virtual reality environments for hazard identification," *International Journal of Occupational Safety and Ergonomics*, 2020, doi: 10.1080/10803548.2020.1728951.
- [38] A. J.-P. Tixier, M. R. Hallowell, A. Albert, L. van Boven, and B. M. Kleiner, "Psychological Antecedents of Risk-Taking Behavior in Construction," *Journal of Construction Engineering and Management*, vol. 140, no. 11, p. 04014052, Nov. 2014, doi: 10.1061/(asce)co.1943-7862.0000894.
- [39] S. Hasanzadeh, J. M. de la Garza, and E. S. Geller, "Latent Effect of Safety Interventions," *Journal of Construction Engineering and Management*, vol. 146, no. 5, p. 04020033, May 2020, doi: 10.1061/(asce)co.1943-7862.0001812.
- [40] M. Habibnezhad, J. Puckett, M. Fardhosseini, H. Jebelli, T. Stentz, and L. Pratama, "Experiencing Extreme Height for The First Time: The Influence of Height, Self-Judgment of Fear and a Moving Structural Beam on the Heart Rate and Postural Sway During the Quiet Stance," *Proceedings of the 36th ISARC*, 2019, doi: doi.org/10.22260/ISARC2019/0142.
- [41] R. B. O. Pinheiro, N. Pradhananga, R. Jianu, and W. Orabi, "Eye-Tracking Technology for Construction Safety: A Feasibility Study," *Proceedings of the 33rd ISARC*, 2016, doi: doi.org/10.22260/ISARC2016/0035.
- [42] K. Chan, J. Louis, and A. Albert, "Incorporating worker awareness in the generation of hazard proximity warnings," *Sensors (Switzerland)*, vol. 20, no. 3, Feb. 2020, doi: 10.3390/s20030806.
- [43] B. Esmaeili and M. Hallowell, "Attribute-based risk model for measuring safety risk of struck-by accidents," in *Construction Research Congress 2012: Construction Challenges in a Flat World, Proceedings of the 2012 Construction Research Congress*, 2012, pp. 289–298, doi: 10.1061/9780784412329.030.
- [44] C. S. Park and H. J. Kim, "A framework for construction safety management and visualization system," *Automation in Construction*, vol. 33, pp. 95–103, 2013, doi: 10.1016/j.autcon.2012.09.012.
- [45] A. Perlman, R. Sacks, and R. Barak, "Hazard recognition and risk perception in construction," *Safety Science*, vol. 64, pp. 13–21, 2014, doi: 10.1016/j.ssci.2013.11.019.
- [46] L. Zhang, X. Wu, M. J. Skibniewski, J. Zhong, and Y. Lu, "Bayesian-network-based safety risk analysis in construction projects," *Reliability Engineering and System Safety*, vol. 131, pp. 29–39, 2014, doi: 10.1016/j.res.2014.06.006.
- [47] Y. Shi, J. Du, C. R. Ahn, and E. Ragan, "Impact assessment of reinforced learning methods on construction workers' fall risk behavior using virtual reality," *Automation in Construction*, vol. 104, pp. 197–214, Aug. 2019, doi: 10.1016/j.autcon.2019.04.015.
- [48] H. Frank Moore and M. Gheisari, "A review of virtual and mixed reality applications in construction safety literature," *Safety*, vol. 5, no. 3. MDPI Multidisciplinary Digital Publishing Institute, 2019, doi: 10.3390/safety5030051.
- [49] Y. Shi *et al.*, "Social Influence on Construction Safety Behaviors: A Multi-User Virtual Reality Experiment," *Construction Research Congress*, pp. 174–183, 2018, doi: 10.1061/9780784481288.018.
- [50] M. T. Shafiq and M. Afzal, "Potential of virtual design construction technologies to improve job-site safety in gulf corporation council," *Sustainability (Switzerland)*, vol. 12, no. 9, May 2020, doi: 10.3390/su12093826.
- [51] H. L. Guo, H. Li, and V. Li, "VP-based safety management in large-scale construction projects: A conceptual framework," *Automation in Construction*, vol. 34, pp. 16–24, 2013, doi: 10.1016/j.autcon.2012.10.013.
- [52] C. Clevenger, C. Lopez, and D. Puerto, "Advances in Engineering Education Interactive BIM-enabled Safety Training Piloted in Construction Education," 2015.
- [53] R. Sacks, J. Whyte, D. Swissa, G. Raviv, W. Zhou, and A. Shapira, "Safety by design: dialogues between designers and builders using virtual reality,"

- Construction Management and Economics*, vol. 33, no. 1, pp. 55–72, Jan. 2015, doi: 10.1080/01446193.2015.1029504.
- [54] S. Côté and O. Beaulieu, “VR road and construction site safety conceptual modeling based on hand gestures,” *Frontiers Robotics AI*, vol. 6, no. MAR, 2019, doi: 10.3389/frobt.2019.00015.
- [55] C. S. Park, Q. T. Le, A. Pedro, and C. R. Lim, “Interactive Building Anatomy Modeling for Experiential Building Construction Education,” *Journal of Professional Issues in Engineering Education and Practice*, vol. 142, no. 3, Jul. 2016, doi: 10.1061/(ASCE)EI.1943-5541.0000268.
- [56] Y. Zou, A. Kiviniemi, and S. W. Jones, “A review of risk management through BIM and BIM-related technologies,” *Safety Science*, vol. 97, pp. 88–98, Aug. 2017, doi: 10.1016/j.ssci.2015.12.027.
- [57] S. Hasanzadeh, N. F. Polys, and J. M. de La Garza, “Presence, Mixed Reality, and Risk-Taking Behavior: A Study in Safety Interventions,” *IEEE Transactions on Visualization and Computer Graphics*, vol. 26, no. 5, pp. 2115–2125, May 2020, doi: 10.1109/TVCG.2020.2973055.
- [58] C. M. Zuluaga and A. Albert, “Preventing falls: Choosing compatible Fall Protection Supplementary Devices (FPSD) for bridge maintenance work using virtual prototyping,” *Safety Science*, vol. 108, pp. 238–247, Oct. 2018, doi: 10.1016/j.ssci.2017.08.006.
- [59] Z. Shang, Z. Shen, and P. D. Student, “A Framework for a Site Safety Assessment Model Using Statistical 4D BIM-Based Spatial-Temporal Collision Detection,” *Construction Research Congress*, 2016, doi: 10.1061/9780784479827.218.
- [60] K.-Y. Lin, J. Son, and E. M. Rojas, “A pilot study of a 3D game environment for construction safety education,” Lin, 2011. [Online]. Available: <http://www.itcon.org/2011/5>.
- [61] S. Garbaya and U. Zaldivar-Colado, “The affect of contact force sensations on user performance in virtual assembly tasks,” *Virtual Reality*, vol. 11, no. 4, pp. 287–299, Oct. 2007, doi: 10.1007/s10055-007-0075-5.
- [62] W. A. Hatem, A. M. Abd, and N. N. Abbas, “Barriers of adoption building information modeling (BIM) in construction projects of Iraq,” *Engineering Journal*, vol. 22, no. 2, pp. 59–81, Mar. 2018, doi: 10.4186/ej.2018.22.2.59.
- [63] D. Clarke, G. McGregor, B. Rubin, J. Stanford, and T. C. N. Graham, “Arcaid: Addressing situation awareness and simulator sickness in a virtual reality Pac-Man game,” in *CHI PLAY 2016 - Proceedings of the Annual Symposium on Computer-Human Interaction in Play Companion*, Oct. 2016, pp. 39–45, doi: 10.1145/2968120.2968124.
- [64] F. Bin, Z. Xi, C. Yi, and W. G. Ping, “Construction safety education system based on virtual reality,” in *IOP Conference Series: Materials Science and Engineering*, Aug. 2019, vol. 563, no. 4, doi: 10.1088/1757-899X/563/4/042011.
- [65] R. Eiris, M. Gheisari, and B. Esmaeili, “Desktop-based safety training using 360-degree panorama and static virtual reality techniques: A comparative experimental study,” *Automation in Construction*, vol. 109, Jan. 2020, doi: 10.1016/j.autcon.2019.102969.
- [66] H. F. Moore, R. Eiris, M. Gheisari, A. M. Asce, and B. Esmaeili, “Hazard Identification Training Using 360-Degree Panorama vs. Virtual Reality Techniques: A Pilot Study.”
- [67] P. Forsythe, “Proactive construction safety systems and the human factor,” *Proceedings of Institution of Civil Engineers: Management, Procurement and Law*, vol. 167, no. 5, pp. 242–252, Oct. 2014, doi: 10.1680/mpal.13.00055.
- [68] M. Habibzhad, J. Puckett, M. Fardhosseini, and L. Pratama, “A Mixed VR and Physical Framework to Evaluate Impacts of Virtual Legs and Elevated Narrow Working Space on Construction Workers’ Gait Pattern,” *Proceeding of the ISARC*, 2019, doi: 10.22260/ISARC2019/0141.

# Single-Word Speech Recognition Using Convolutional CNN Neural Networks

<sup>[1]</sup>Nurbapa Mekebayev, <sup>[2]</sup>Orken Mamyrbayev, <sup>[3]</sup>Dina Oralbekova, <sup>[4]</sup>Madiyar Tasbolatov

<sup>[1][2][4]</sup> Al-Farabi Kazakh National University

<sup>[2]</sup> Kazakh national women's teacher training university

<sup>[3]</sup> Satbayev University

<sup>[1][2]</sup> Institute of Information and Computational Technologies, Almaty, Kazakhstan

Email: <sup>[1]</sup>nurbapa@mail.ru, <sup>[2]</sup>morkenj@mail.ru, <sup>[3]</sup>dinaoral@mail.ru, <sup>[4]</sup>aizhir.mt@gmail.com

**Abstract**— This work focuses on monosyllabic speech recognition, where the ultimate goal is to accurately recognize a set of predefined words from short audio clips. It uses a data set of speech commands that consist of 64,000 one-second utterances of 30 short words, from which we learn to classify 10 words, as well as classes for "unknown" words, and also "Silence". We use a convolutional neural network (CNN) with one-dimensional convolutions on the raw audio signal to classify the samples. The results show that the model can predict samples of words it saw during training with high accuracy, but it somewhat struggles with generalizing to words that are beyond the training data, and extremely noisy samples.

**Keywords**— speech recognition, neural network, CNN, audio signal, MFCC

## I. INTRODUCTION

Currently, one of the most pressing problems in the field of information technology is the problem of speech recognition. The efficiency of using computer systems directly depends on this, since speech is considered the most common and natural phenomenon of human communication and significantly speeds up the process of entering information and managing mobile systems. Information technologies are rapidly developing and are widely used in information exchange. In this regard, the development of speech recognition plays an important role.

In everyday life, language is a natural means of human communication. Everyone knows that in the course of the development of science and technology, scientists and engineers have been studying the problem of verbal communication between the user and the machine for many years.

It should be recognized that many companies and individual developers have made significant progress in the development of speech recognition technologies, but it should also be recognized that they are still not widely used in Kazakhstan. This is due to the presence of sound interference and the peculiarities of the speaker's speech style.

In this regard, the most urgent task in solving this problem is to identify the speaker in the automatic speech recognition system.

Machine learning is a branch of artificial intelligence, the characteristic feature of which is not the direct solution of a problem, but learning in the process of applying solutions to many similar problems. Machine learning is located at the intersection of mathematical statistics, optimization methods, and classical mathematical disciplines, but it also

has its own specifics related to information extraction, data mining, and computational efficiency problems [1]. The scope of application of machine learning technologies is wide and constantly increasing, including pattern recognition, medical and technical diagnostics, statistical analysis, forecasting, management and decision-making tasks, text array processing, and speech synthesis. For example, in linguistics, machine learning helps determine the grammatical characteristics of words; in phonetics, machine learning is used to predict the pitch frequency and length of phonemes. Prosodic characteristics, such as determining the length and location of pauses, and predicting intonations, can also be taught.

## II. THEORY AND METHODS

This section presents the basic theory of using audio data for speech recognition models, the models used in the final architecture, and the basic principles of learning neural networks.

### A. Sound as data

The data set consists of a set of wave files, each of which is approximately one second long. To use this data, each file is sampled into a vector with a sampling rate of 16000. A common speech recognition strategy is to first extract features from the raw waveform. Commonly used speech functions, such as spectrograms, log-Mel filter banks, and Mel-frequency cepstral coefficients (MFCC), convert the raw waveform to the time-frequency domain [2]. These functions are then used as input to the model. [3] show how log-Mel filter banks can be used as input features for a neural network.



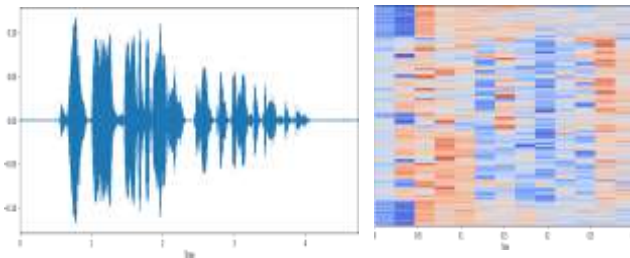

Fig. 1. Sample showing the word as a raw waveform (left) and MFCC (right)

**B. Convolutional CNN neural networks for speech recognition**

The most common machine learning models are artificial neural networks, which are used to process input data from a combination of distributed simple operations that depend on the parameters being trained. Modern neural networks are used in forecasting tasks, image and speech recognition, text generation, and many others. The most optimal types are convolutional networks and recurrent neural networks.

Convolutional neural networks consist of four basic operations: convolution, nonlinearity, union and classification. Optionally, models can include batch normalization as well as dropout. These operations are usually added together so that convolutions are followed by non-linearity such as ReLU, then this operation is repeated several times, after which the join operation is used. When the network is deep enough and the original input signal is counted by pooling to a size that can be controlled, it is passed to the classification part of the network. If batch normalization is used, it is usually used after convolution, but before non-linearity.

**C. Architecture**

A convolutional neural network receives a sequence of raw input signals, splits them into frames, and outputs a score for each class, for each frame. The network architecture consists of several filtering stages, followed by a classification stage. The filter stage includes a convolutional layer, followed by a time layer of maximum Union and non-linearity (tanh ()). Our optimal architecture included three filtering stages. The processed signals coming out of these stages go to the classification stage, which in our case is a multi-layer perceptron with one hidden layer. It outputs conditional probabilities  $p(i/x)$  for each class  $i$ , for each frame  $x$ , using the Soft Max layer [19]. The network is trained by the cross-entropy criterion maximized by the stochastic gradient ascent algorithm [20].

**D. Convolutional layer**

While «classical» linear layers in standard MLP accept a fixed-size input vector, it is assumed that the convolutional layer is fed by a sequence of  $t$  vectors frames:  $X = \{x_1, x_2, \dots, x_T\}$ . The convolutional layer applies the same linear transformation over each successive (or overlapping  $dR$  frames) window of  $kR$  frames. For example, the transformation in frame  $t$  is formally written as:

$$N \begin{pmatrix} x^{t-(kR-1)/2} \\ \vdots \\ x^{t+(kR-1)/2} \end{pmatrix} \tag{1}$$

Where,  $N$  is a  $d_{out} \times d_{in}$  matrix of parameters. In other words  $d_{out}$  filters (rows of the matrix  $N$ ) are applied to the input sequence.

**E. Max-pooling layer**

These kinds of layers perform local time maximum operations on the input sequence. More formally, the transformation in frame  $t$  is written as:

$$\max_{t-(kR-1)/2 \leq t \leq t+(kR-1)/2} x_6^d \tag{2}$$

with  $x$  being the input,  $kR$  the kernel width and  $d$  the dimension

**III. DATA**

Set consists of 64,000 one-second utterances of 25 short words such as “кел”, “бар”, “аяқ” and “қол”. This data set is designed to help build voice interfaces for applications with the definition of keywords that can be useful on mobile devices and microcontrollers.

The goal is to classify the following words: "кел", "бар", "жүгір", "сақтан", "аяқ", "қол", "орман", "тоғай", "алыс" and "жақын". All other words are marked as "unknown" and are used to help the model learn a representation for all words that are not included in the 10 words to be classified. The last class is "silence", which is samples without a word.

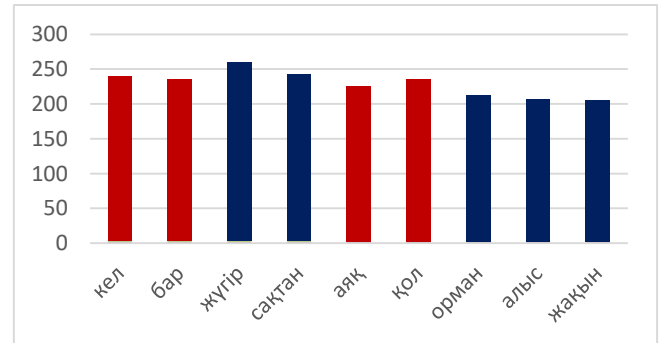

Fig. 2. Calculations for each class in the data set of voice commands. The blue examples represent words that need to be classified, the red examples represent an unknown class

The test set provided by the Kazakh speech corpus consists of approximately 150,000 additional utterances, including words and speakers that do not appear in the speech command dataset.

The files in the dataset are arranged in folders by label, with file names starting with a hash representing the speaker, followed by a number representing the number of times a statement by the same speaker appears in the dataset. The data is split into training and validation sets using a hash, so that the same speaker does not appear in both sets.



The Kazakh speech corpus also provided a set of audio files that are designated as background noise, using these files, we create data for the silence class, as well as background noise that is used during training. Some files that were recognized as silent but were incorrectly marked were corrected and used as additional silence during training.

#### A. Data augmentation

Is a way to increase the amount of training data by modifying the available data so that it can still be identified with the same label. Increasing the amount of data showed that this is a simple and effective way to reduce overvoltage and thereby improve the performance of the model. Increasing the data can also help the model learn a wider range of features, since the extended samples can be very different from the original training samples, but they can still be identified as the same.

Three methods of data augmentation were used: time-shifting the sound, scaling the amplitude, and adding noise. The first step, time offset, is applied with a probability of 49.8 % to each sample. Enlarged samples are shifted forward or backward in time up to 19.6 % of the original length of the samples. Sometimes this results in a partial excision of the utterance in the sample, but the probability of this is negligible. This augmentation method should help the model learn a more time-invariant representation of statements, since they can appear anywhere in the sample.

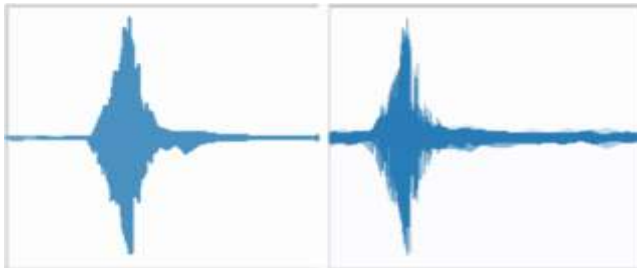

Fig. 3. Sample of the word "Кел" as the original sample (left) and its augmented version (right)

The second amplification method is mixing noise with a sample, this is also applied with a probability of 49.8 %. Noise is generated in the same way as silence is generated during training, when up to two samples from the background sound of the data set are scaled and added together. This noise is then added to the original input, which scales between 74.9 % and 124.6% of its original amplitude. Adding noise should help the model better distinguish relevant information from data.

#### IV. RESULTS

The evaluation of results is divided into three sets, a validation Set, and two sets of tests. The validation set contains approximately 10% of the samples in the dataset. These two test suites are based on two test leaderboards, public and private, which contain 30% and 70% of the test data, respectively, for clarity, they will be designated as a public test Suite and a private test Suite. Accuracy,

accuracy, recall, and F1-scores are reported for validation data, but since we don't have access to the correct labels for test suites, only accuracy scores will be reported for them. Some analysis of manually validated predictions on the test set will be discussed, as the test sets contain words and speakers that are missing from the training data, and analyzing the predictions will provide a deeper understanding of the strengths and weaknesses of the model.

Before using pseudo-tags in the training process, the model achieves 96.5% accuracy on the validation set, 86.6% accuracy on the public test set, and 87.8% accuracy on the private test set. After including pseudo-labels in the training process, the model achieves 96.7% accuracy on the validation set, 87.8% accuracy on the public test set, and 88.6% accuracy on the private test set.

TABLE 1. FOR EACH CLASS THE ACCURACY, RECALL AND F1-SCORES FOR THE VALIDATION SET ARE SHOWN IN

Label	Precision	Recall	F1-score	Support
кел	0,98	0,98	0,98	236
бар	0,95	0,97	0,96	232
жүгір	0,93	0,96	0,95	257
сақтан	0,96	0,97	0,98	239
аяқ	0,96	0,97	0,97	223
қол	0,94	0,96	0,95	233
орман	0,87	0,97	0,94	210
алыс	0,93	0,96	0,94	204
жақын	0,94	0,95	0,93	203

#### V. CONCLUSION

This work showed that a model that uses one-dimensional convolutions along with reasonable learning methods can be used effectively to recognize monosyllabic speech, but a lot of work needs to be done to generalize to invisible samples and work with extremely noisy samples.

**Acknowledgements:** AP08855743 «Development of an end-to-end automatic speech recognition system for agglutinative languages»

#### REFERENCES

- [1] Abdrahmanova, Je. R. (2019) 'Mashinnoe obuchenie: Obzor i primeneniye'.Tehnika i tehnologii: Puti innovacionnogo razvitiya: sbornik nauchnyh trudov 8-j Mezhdunarodnoj nauchnoprakticheskoj konferencii. Jugo-Zapadnyj gosudarstvennyj universitet [Machine Learning: Overview and Application.Technique and Technology: Ways of Innovative Development: a collection of scientific papers of the 8th International Scientific and Practical Conference. Southwestern State University]. Kursk. Pp. 9-12.
- [2] Zhang, Y., Suda, N., Lai, L. & Chandra, V. 2017, Hello Edge: Keyword Spotting on Microcontrollers, CoRR, vol. abs/1711.07128.

- [3] Sainath, T.N. and Parada, C. 2015, Convolutional neural networks for small-footprint keyword spotting. In Sixteenth Annual Conference of the International Speech Communication Association.
- [4] J. Bridle, "Probabilistic interpretation of feedforward classification network outputs, with relationships to statistical pattern recognition," in *Neuro-computing: Algorithms, Architectures and Applications*, 1990, pp. 227–236.
- [5] L. Bottou, "Stochastic gradient learning in neural networks," in *Proceedings of Neuro-Nmes 91*. Nimes, France: EC2, 1991.
- [6] Orken Mamyrbayev, Turdalyuly, Nurzhamal Oshanova, Tolga Ihsan Medeni, Aigerim Yessentay. *Voice Identification Using Classification Algorithms* // We are IntechOpen, the world's leading publisher of Open Access books Built by scientists, for scientists. June 25, 2019. London.
- [7] Kalimoldayev, M., Mamyrbayev, O., Mekebayev, N., Kydyrbekova, A. *Algorithms for detection gender using neural networks* // *International Journal of Circuits, Systems and Signal Processing*. 2020
- [8] Mamyrbayev, O., Alimhan, K., Zhumazhanov, B., Turdalykyzy, T., Gusmanova, F. *End-to-End Speech Recognition in Agglutinative Languages* *Lecture Notes in Computer Science* (including subseries *Lecture Notes in Artificial Intelligence* and *Lecture Notes in Bioinformatics*), 2020
- [9] Aizat, K., Mohamed, O., Orken, M., Ainur, A., Zhumazhanov, B. *Identification and authentication of user voice using DNN features and i-vector* // *Cogent Engineering*. 2020
- [10] Mamyrbayev O., Toleu A., Tolegen G., Mekebayev N. *Neural Architectures for Gender Detection and Speaker Identification* // *Cogent Engineering*, ISSN: 2331-1916. – 2020. Volume 7, - Issue 1

# Gender Differences In Learning Mathematics With Digital Games

L. K. Pulasthi Dhananjaya Gunawardhana

Senior Lecturer, Department of Information & Communication Technology, Faculty of Technology, University of Sri Jayewardenapura, Sri Lanka

**Abstract**— Digital games are the latest learning technologies which need to be confirm the possibility for applying to both gender equally. Through this paper we are going to discuss about the gender difference on game and how possible apply digital games for learning mathematics with the gender differences. We have reviewed applicable research methods to gain fruitful results on gender aspects. In here we have discuss about the gender-based variety in educational games, developing proper game model, and research and gather evidences on gender aspects and possibility of using digital games for learning mathematics. Through this paper we are going to reveal that boys are more likely to play digital game than girls. And also this paper highlights the differences which type of games boys and girls would like to play and we have describe the reason for choosing games on gender based.

**Keywords**— Gender Differences, Digital Games, Educational Digital Games, Gamification, Game Design, Gender Aspects

## I. INTRODUCTION

In modern world children are influence with latest technology. Most of them used to spend their leisure time playing with digital game and etc. Current development in technology certainly effect for education as well. As famous researcher Prensky talk about through his paper, students in modern world are not compatible with educational system which running currently. Therefore, with the help of technology teaching and learning methods should develop for the current needs [1]. Most of the young crowd are like to use game with VR (Virtual Reality). The gaming technology which interact education may helpful to change the learning techniques. Engagement and motivation are key benefits of using digital games, but it is yet not enough to count down for educational purposes. There is a relationship amid playing and the mathematical thinking of a student. Understanding this is not a new singularity. A researcher named Van Oers once said through his paper, “by playing digital games make the opportunity to practice the selected lessons and escalate the skills” [2]. When developing the technologies, the connection between the visual and spatial impetus extended the chance of involve with digital games. Most of the modern digital games make an effect for students to engage with maths.

As to the recent studies indicates that 90% male game players belong to age group of 8 to 18. And also leading game developing company have spent nearly 8 billion US dollars developing digital game for the past couple of years [3]. Digital games, which has active nature, productive and motivational opportunities are efficacious technology, whose likely of being applied for learning has been progressively discussed since the 2000s. The feature that will be measured through this report could be varied with regards to students regarding their approach and acceptance towards digital game based learning, exclusively ultimate

gender differences. Through this paper we are going to discuss about characteristics of the gender towards digital games, based on that, we are going to general discuss on gender based adoption, Gender Stereotype on games, gender-sensitive approach of designing games for educational purposes. Then we are going to discuss based on gender difference, student’s engagement on digital games and deliberates the effect on learning mathematics.

## II. GENDER DIFFERENCES ON DIGITAL GAMES

In general, most of the digital games available on the market are played by boys rather than by girls. The general consensus regarding digital games is that boys tend to play these digital games for longer periods than girls do, and that males are more likely to use digital games than females. Previous research has confirmed that most girls are likely to engage in role- playing games rather than action and fighting games. Even as the general popularity of digital games continues to rise, the majority of people who play them are still males. Boys having a higher need for achievement when they playing digital games. Once two researchers name Boyle and Conolly mention through their paper that, this need for achievement is linked with challenge [4]. Hartmann and Klimmt (2006) highlight the reason for this gender gap in playing digital games as being linked to personal traits in each gender. Apparently, they said that effectiveness on trait can be clarified by three gears. These are; motivation for success, the necessity to success, and finally, self-efficacy. These three factors are more important for boys rather than girls [5]. Boys who play games are expecting more challengeable environments than girls.

Lucas and Sherry (2004) discovered that the game player is looking for a game that will evoke various fresh and powerful feelings and experiences, and will allows the player to take risks. Digital game developers are therefore always trying to evoke these extraordinary feelings in its

players, as this desire for these feelings is the key motivation for playing digital games. The researchers also confirmed that this desire is more significant for boys than for girls. Additionally, they have found that girls are more likely to involve themselves with non-violent digital games [6]. Agosto (2004) mentions in his article that girls characteristically show pro-social patterns and enjoy playing digital games that involve interaction with society and human relationships. Most digital games provide a chance to interact with society and with other people rather than being action-oriented, but when these characteristics of social interaction are absent in the game, girls get bored and discontinue playing the games [7]. Girls are always good on obviously express their preference on something, so as for games as well. Most of the researchers mention that they value digital games which has meaningful dialogues and good interaction with it users. Frequently, digital games deliver opportunities for social interaction. Lack of social interaction in modern digital game count as the reason for girls not like to involve with games [5].

Because boys and girls are usually different in many ways, the type of digital games they prefer to play are also different. The motivation factor for play digital games also differ between genders. As previously discussed, these preferences are due to different interests and desires, which have been acquired through socialization. Even though boys generally select action, adventure, and simulation games with violent content, girls tend to prefer puzzles, board games, and role playing games. When selecting digital games, boys generally select games that have an element of competition and winning, but girls predominantly select games for their storylines and for the characters in that particular game. The evidence that we have gathered suggests that girls prefer games that are unhurried, and like to select a colourful, slow-moving graphic user interface (GUI). Because of this tendency, we chose a role-playing game for girls for our research in order to determine the possibility of using digital games as an educational tool.

When discussing about best-selling digital games we have found that only few of the character are female, and major part of the roles are rather spectators than active game players. As Graner highlighted from his paper, that stereotypes and archaic models are useful to represent girl game characters. Most of these girl character are highlights with weak and need to be secure by strong boy or male character and these boy/male character design to elaborate female sexuality [8]. This is a falsification can be seen in most games and this could be major reason for girls not interest in playing digital games. But when we look at digital games made for girls, female characters express strong preferences when compare to games play by boys. Gender differences also affect to game avatars as well. Most of the boys who play games select male avatars, while girls select female avatars. As to our study we found that boys who play games are always looking powerful avatars,

while girls as usual selecting fashionable and beautiful avatars.

### III. GENDER ASPECT ON DIGITAL GAMES

Based on Knowledge Space Theory, Kickmeier et al refine the background of the educational digital gaming system to escalate the children's skills and gender differences and the usage of the fundamentals [9]. We are expecting that given concept requirement a conjecture connection between these elements can be proven which captures the experience how to consequent through a research and empirical studies could be count as individual factors. Not that all, Kickmeier et al introduce a prototype that integrating individual factors manipulating student's selection on educational digital games and it has confirmed gender differences in order to model a structure for gender differences in connection between the individual factors as it is link with adaptation of an educational digital gaming system. Use of this methodology prove that there is a possibility for students to states that mixtures of individual aspects could be helping to reduce to an expressed sequence by creating essential expectations based on current research evidences. As we discuss about gender aspect in previously, it covers the many features about the digital games on gender differences which have been verify about key concepts and characteristics. These key hypotheses mention characteristic of the gender differences and relatively clarify the gender gap in the different digital game characteristics.

These different selections of the digital games by girls and boys, can be clarified as gender differences in competition placement and interaction preferences. These factors could be the reason for encouragement to involve with digital games. This will be helpful to turn into manipulating the selection of the type of digital game and the usage. Duration of playing digital games also reason for effective for uplifting skills of a students. We have developed this framework further to do our research which will be discuss in next topic. When we reviewing our research results in which we done, web based educational games and e-learning systems has shown that girls are always prefer vibrant background design which use attractive colours, while boys prefer a complex design and they are attracted for more realistic graphical elements and interactive features. There is one reasonable explanation for the judgement for the gender differences using for educational digital games. In 2003 two researchers name Dickhäuser and Stiensmeier said that the features in digital games are the reason for its player's success or failure, as it is meticulously identify and verify the gender differences. Boys are habitually like to explain their success and how they did it. But girls are incline to point the cause of failure more likely than boy. These features preferences are referred to the self-efficacy principles that can be verified to be higher for boys in the background of digital games [12]. Two researchers' name Ziegler and Stoeger once mention in their paper that, a flawed ascription manner could seems to be in other areas as well and it could be linked with



unfitted performance that will sooner or later lead to prevention [13]. Apparently for that the most of the variables could be modified by assisting in clarifying the procedural arrangements in digital games. With regards our framework, reason for playing digital games could be count as escalating computer literacy, but the assumption of playing digital game successfully can be count on self-efficacy. These assumptions for playing digital games would be a liable aspects for selection to play an educational digital games.

#### IV. DIGITAL GAME FOR MATHEMATICS

##### 4.1 Standards for the games.

In here we are going to discuss the required guidelines for designing a proper digital game for the purpose of teaching mathematics. In our previous discussions we have elaborated on the factors of gender aspect why the young students like to involve with digital games. Digital games can be applied as a very effective learning method that can be introduced to teach certain subjects. Digital games help to sharpen the skills such as; problem-solving, exploration, collaborating and working as a team as well as providing support to enhance the knowledge and skills that can be transferred depending on the situation and be effective in an educational context. There are two key principles which need to be attached to design a proper educational digital game. These key principles are described as below.

**Engagement:** - Key factors which cause to engage in digital game as we found earlier are the user goals in each stage whether individual or group, they play a particular digital game and feedback they get. Feedback is necessary in order to identify the strength and weakness and to score better at next level. The digital game, we are planning going to design should be easy to deal within the first level and it should be made difficult at the next levels. These should be more new features added to the game compared to previous level. The challenges given should match with the student's age group and subject as well. This will enable the players to achieve initial goals and see themselves the improvement of the performance. This could be combined with the controlling factor of the educational gaming are of the learning environment.

**Active Learning:** - When we plan to design a proper digital game which is actively used for an educational purpose the goals of such an exercise should be very clear to it users. It should also provide for teamwork. The game which we develop is based on logical thinking and problem-solving. By solving mathematical problems either by the player himself /herself or as a team it helps to explore the options and solving problems by discussing with each other. This game should help to refine the logical thinking related to mathematical sums as well as practise mathematics as learned in a school. Since these game enables the players to tryout their guesses if they are not sure of the answer and they can get the correct answer by changing a few guesses. If a student plays in a team they could discuss and select the correct answer. This particular

game has been design to give opportunity to practice and gain working skills. This game has been designed learn while playing, which is easy to increase the learning skills and go for higher grade.

##### 4.2 Game Elements

To develop better educational game, we need to identify the elements of the games. Game element can divide into 3 main parts. They are Dynamic, Mechanism and Components. In 2012 two researchers named Werbach & Hunter illustrated the hierarchy of the Game elements through a pyramid which is shown in figure 1.

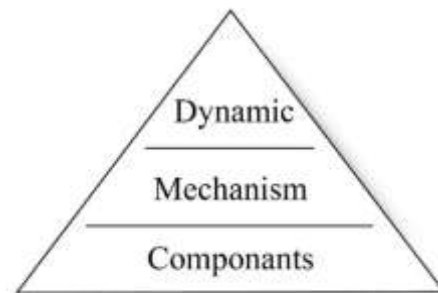

Figure 1: hierarchy of the Game elements [14]

**Dynamics** - Dynamic defines the abstract of the educational game system. Dynamic connect three important layers, especially for educational games. By describing these three layers we can identify how important these layers have become when building a proper educational digital game.

**Emotion** – This is the element in which the users/players show their feedback toward to the game they have played. When they complete the given task usually they feel happy. At the same time when the game release new features or allow the player to unlock new stage, etc. So player feel enthusiastic and get required motivation to play the game further. As to our view educational games never let the students to feel frustrated. It makes them to feel happy and motivate them to learn while playing the game. It also helps to connect the student and the teacher within the scope of the school curriculum.

**Relationship** – This is the factor that shows us that two or more thing connect and function together. Otherwise this cannot be termed as a successful game. Relationship plays the main role within the dynamic element which attracts the users to the game. In an educational gaming system, it gives chances to have possible answers to given questions to win the game. This makes game users to play as a team to achieve their goals specified in the game. This could be an attributed as a valid reason for game players to interact with the system.

**Boundary** – There should be a limit to playing games. If there is no limit, these children/students may get addicted to such games. There should be appropriate guidance for the game players. These boundaries play different roles



depends on the nature of the game. This can be done by the system when developing the game, by adding monitoring and controlling panel for the teacher/parent. Furthermore there are few more roles that could apply as a mediator or a normal member.

**Mechanism:** - This can be termed as the second element of game designing. Werbach and Hunter once said, “basic processes that drive the action forward and generate player engagement” [14]. There are four main elements we consider under Game Mechanism. They are, Points, Badges, Rewards and Lead board.

**Points** – These are the key currency of the game. To earn points, a player has to work hard and achieve the given task. Point allocation is a great method to illustrate players’ progress and capacity compared to other players. This will help the positioning of a player in the ranking order. The point system is a highly motivational one for the players and it is very effective as well. Based on the collection of points, it is easy for teachers to identify the weak students and the area in which the weakness is evident.

**Badges** – In educational digital games, the badging method is adopted to highlight the player’s competencies. This will enable other players to recognise his or her competencies and talents for a particular game. In educational digital games, players are able to earn their badges by playing the game with their achievements. Badges symbolise the player’s profile and achievement records and they are the elements responsible for maintaining the challenges in a particular game. Badges can be a source of help to the game users by giving necessary feedback which will be a source of identifying the progress of a user.

**Rewards** – This is another method of encouraging the player to spend more time with the game. Once the player successfully completes the given task or the particular stage, the player will be rewarded. According to educational digital game theory brought forward by Zichermann and Cunningham, these rewards must be non-monetary and the player is not given points for his or her success either [15]. This will provide more opportunities and chances of getting rewards by the successful player/student. Once the mission is completed and the player gets satisfied, they will be happy and enthusiastic to complete other the missions. Game players are naturally motivated by the action alone itself.

**Lead board** –Through this feature, the progress made by each player in a particular game and their achievements are shown. The collection of points and badges will be announced here. By collecting points and badges and by displaying them on a lead board, each player by themselves could improve their ranking as well as getting recognised by other players. It will also help the player or team to adopt new techniques to get on top of the lead board. When the player is found to be in a lower position of the lead board, necessary measures could be adopted to encourage the player to advance on the lead board and improve their ranking.

**Components:** - The final part of the game element is the components. There should be relevant components to build a proper educational digital game. In this section we will give a brief description on the importance of components. Levels, Privileges, and Teamwork are the key components which should be within a proper educational game.

**Levels** – This help the game players to reach the given target step by step without getting bored of the game. In order to reach to higher levels the game players need to gain points which are indicated in the game itself. These points motivates the player to level up in a game. Game players who socialize with other players try to find out more tactics when they are in the same level. When the game player level-up they can unlock new features and this will help them to motivate to explore further into the game.

**Privileges** – This is similar to “rewards” which we have discussed earlier under the subject of mechanism. Privileges help the players to avoid unnecessary features and help to unlock the levels as well as new abilities which drives the game players towards its approach. Digital games rather used to be designed with minimum number of obstacles in order to gain the desired abilities of the player. This is why we should give the privileges to a game player which encourage them to play well. The main idea of providing a component like privileges is to motivate the player as well as to minimise the frustration of player.

**Teamwork** – Teamwork is an important aspect which a students have to learn from the school. Finding an answer for a difficult question is much easier when they try as a team rather trying it on your own. Therefore the game player needs to co-operate with each other as team in order to succeed in a game. Apart from that connectivity with other team members while playing the game is important to have a successful outcome. It will also help to develop new friendships and contacts as well.

## V. DISCUSSION

Following the above discussed guidelines we have developed the educational digital game for practising mathematics. In accordance with to the discussed guidelines this game production framework contained the following phases: Analysis, Design, Development, Implementation, and finally the Evaluation. Therefore, we developed this model game carefully and work thorough as to the requirements analysis, in order to developed proper game. We request from teacher to observe the educational process and the students’ performance during classes time. For this research we took 120 students from 3 different countries, numbering 60 students from UK, 36 from Australia and 24 from Sri Lanka. These student group is mix of girls and boys in each country.

Before start the research we gave questionnaire to find-out what is the most desired gaming typing of the student based on gender. Then we have found most of the boy like for racing game and role play game for girls. So we have selected two games according to gender that contain

teaching element for teaching general mathematics to grade 7 students. This exercise took into account several factors: the students' level of memorisation, learning, logical thinking, problem solving, creativity, socializing (which represents different analytical levels), gender differences, and the ability for us to receive their feedback on possible improvements of them. Based on these factors, we will discuss the effectiveness of using digital game as an educational tool. The most relevant method for testing effectiveness is to evaluate the method's results (in this case, student's skills scores) in comparison with the results of the traditional method. The following charts show the head count of the students in each country based on gender.

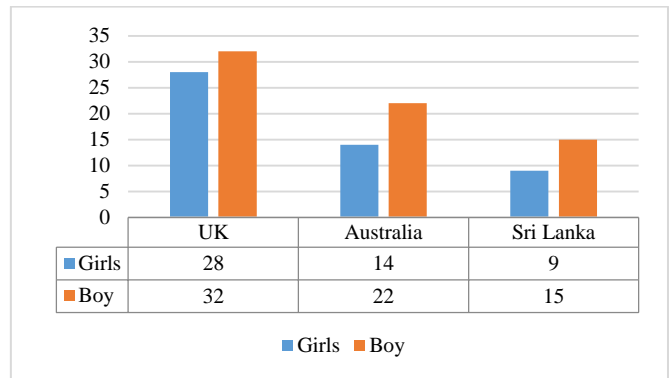

Table -1: Students Divide by Gender

Table 2: Before and After Playing Games

Before Playing Games										
Student	Problem Solving		Critical thinking		Teamwork		Analyse and Classifying		Creativity	
	Boys	Girls	Boys	Girls	Boys	Girls	Boys	Girls	Boys	Girls
UK	54%	52%	45%	46%	49%	45%	40%	41%	40%	42%
Australia	64%	62%	56%	55%	57%	55%	45%	44%	50%	52%
SL	70%	71%	44%	45%	54%	50%	42%	42%	54%	56%
After Playing Game										
Student	Problem Solving		Critical thinking		Teamwork		Analyse and Classifying		Creativity	
	Boys	Girls	Boys	Girls	Boys	Girls	Boys	Girls	Boys	Girls
UK	81%	78%	62%	63%	62%	58%	54%	55%	51%	53%
Australia	84%	85%	80%	82%	68%	65%	65%	64%	57%	59%
SL	82%	83%	65%	66%	64%	60%	68%	67%	60%	62%

We have interviewed teachers from the selected schools to find out the progress of the students, after they play digital games. We have given two types of game grouping them based on gender. For the boys we gave a racing game and for the girls a role play game. This Research concentrated on the subject of finding out possibility of using educational digital games as a teaching tool for mathematics. We have requested from the class teachers to monitor their progress and mark them accordingly.

We request from the class teachers to monitor their progress and mark them accordingly. As to the table below which given the result of the research, it has been a successful exercise. We tested these children before and after playing game. We have given student to small test after usual in class activities (without involving computer games). Then with the help of the class teachers, we let these kids to play and practise mathematics. This process took around 3 - 4 months. Then we provide small test to check their progress. All the question papers which we were distributed, prepared by according to the syllabus and these papers were marked by the class teachers in each country. We let them play this game only when mathematic class session which men around 1 hour per day for a week (5 days). Table 1 indicates the result of the research. As the four teachers in the three different countries which we have mentioned said, that the student's "Problem Solving" skill was level up as we expected. The next highest rate is the "Critical Thinking" factor. This research also reveals that students show progress in mathematical subjects when student get

involve in educational digital games. When the student practice mathematics using these digital games again and again, it help them to practice to solve mathematical problems in a more logical manner and make them to do it easy. According to our survey digital games for secondary school students are constant in showing the popularity among them for involved in educational digital games. The feeling of excitement when playing a games make them to go for the completion of the game even it is complex nature. There was also a high degree of acceptance amongst students that educational digital games could be meaningfully applied for learning purposes. Table 1 below explain this scenario.

As to the result shown in table 1 we can see how effective is that digital games are. When boys played these games to practice mathematics they showed increase of their performance. These results also same to girls as well. Since these kids have spent certain time limit guide by class teachers on digital games, the results regarding their performances got increased. Additionally, these results provide teachers and parents to guide their students to play games even for educational purpose accordingly. The results further analysed the differential effect on two gender groups. An important effect was detected from male students when comparing to female students. In teamwork skills female players indicates the lower results when compared to male students in both before and after playing games. And overall female student's results are lower than male student's results, except in creativity skills. In

creativity skill, results show female student's results are higher than male student's results.

Furthermore, we have find out that boys are more likely to play digital game than girls. And also this paper highlights the differences which type of games boys and girls would like to play and we have describe the reason for choosing games on gender based. When take boys they incline to select games on spatial reasoning. They are most likely to play adventure type, racing games, shooting games and sports games such as like football, cricket, basketball, etc. When talking about girls they are like to select logical base or problem solving digital games and role play type digital games. In general boys are better than girls on mathematics. In this research we have emphasised that boys are not only like to play digital games that they need a guidance's based using graphics or illustration.

However, most of the games provide a substance for several types of mathematics procedures. Therefore, digital games substitute extra context to help students to think logically by playing games.

As to our research outcomes, it suggested that girls are enjoying characters of the digital games. Nevertheless lately there is an increased involvement of females using digital games. Apart from that advent of feeling of females and eager to accept the modern digital games, this improvement reflects the increasing awareness on gender specificities in digital games accordingly leads to the games that interesting and engaging female players. With the difference of the digital games for gender specific features and preferences, this enhancement could boosted further. Through gender specific version on digital games the understanding the clarifying a typically male or female concerned with digital games could be overcome towards the improvement of the games that appeal both, male and female players, could be made. Through this paper we have discussed about the framework that can be helpful to develop a digital game on both gender aspects. The understanding on gender based difference could be directing in certain procedures to be more effective improvement and the digital games concluded the understanding of one proper digital game for both genders instead of different games, and therefore using resources more effectively.

## REFERENCES

- [1] Prensky, M. (2001). Digital natives, digital immigrants. *On the Horizon*, 9 (5). Retrieved February 23, 2009
- [2] Van Oers, B. (2010). Emergent mathematical thinking in the context of play. *Educational Studies in Mathematics*, 74, 23-37.
- [3] Child Development Institute. (2012). Video games and children. Retrieved September 18, 2012
- [4] Boyle, E. & Conolly, T. (2008). Games for Learning: Does Gender Make a Difference? In T. Conolly & M. Stansfield (Eds.), *Proceedings of the 2nd European Conference on Games Based Learning* (pp. 69-75).
- [5] Hartmann, T. & Klimmt, C. (2006) Gender and computer games: Exploring females' dislikes. *Journal of Computer Mediated Communication*, 11, 910-931. Retrieved November 4, 2008
- [6] Lucas, K. & Sherry, J. L. (2004). Sex differences in video game play: A communication based explanation. *Communication Research*, 31, 499-523.
- [7] Agosto, D. (2004). Girls and gaming: A summary of the research with implications for practice. 31, 8-14.
- [8] Graner Ray, S. (2004). *Gender inclusive game design*. Hingham: Charles River Media Inc.
- [9] Kickmeier-Rust, M. D., Albert, D., & Roth, R. (2007). A Methodological Approach to Address Individual Factors and Gender Differences in Adaptive eLearning. In K. Siebenhandl, M. Wagner, & S. Zauchner (Eds.), *Gender in E - Learning and Educational Games: A Reader* (pp. 71-84).
- [10] Aikaterini Katmada, Apostolos Mavridis and Thrasylvoulos Tsiatsos "Implementing a Game for Supporting Learning in Mathematicss" *The Electronic Journal of e-Learning* Volume 12 Issue 3 2014, (230-242)
- [11] Lowrie, T., & Diezmann, C. M. (2010). Solving graphics tasks: Gender differences in middle-school students. *Learning and Instruction*.
- [12] Dickhäuser, O. & Stiensmeier-Pelster, J. (2003). Gender differences in the choice of computer courses: Applying an expectancy-value model. *Social Psychology of Education*, 6, 173-189.
- [13] Ziegler, A. & Stoeger, H. (2004). Evaluation of an attributional retraining (modelling technique) to reduce gender differences in chemistry instruction. *High Ability Studies*, 15, 63-83.
- [14] Werbach, K., and Hunter, D. (2012). *For the Win: How Game Thinking Can Revolutionize Your Business*. Wharton Digital Press.
- [15] Zichermann, G., and Cunningham, C. (2011), *The Gamification by Design: Implementing Game Mechanics in Web and Mobile Apps*. O' Reilly Media, Cambridge.

# Conceptualization Of Chemical Kinetics Using A Visually Enhanced Teaching Technique; A Developed MS Excel Worksheet/System

<sup>[1]</sup>L.S.L.K. Fernando, <sup>[2]</sup> K.R.R. Mahanama

<sup>[1]</sup>Faculty of Graduate Studies, University of Colombo, Sri Lanka

<sup>[2]</sup>Department of Chemistry, University of Colombo, Sri Lanka

Email: <sup>[1]</sup>lankakumarisrilanka@gmail.com

**Abstract**— Chemical kinetics or reaction kinetics is renowned as a division of physical chemistry which includes with understanding the rates of chemical reactions. As physical chemistry lessons play a vital role in secondary level chemistry syllabus in Sri Lanka, in order to understand the concepts of chemical kinetics the use of only traditional chalk and board method is inadequate. Accordingly, this study was carried out with the objectives of developing a suitable teaching aid using MS Excel and visual basic to conceptualize the theories in chemical kinetics enabling to promote the insight while upgrading the standard of chemistry education by combining it with visually enhanced teaching. Thirty students with similar knowledge level were randomly divided into two groups and same chemistry lessons were conducted leaving only one difference in their instructional method; the MS Excel worksheet was used along with the traditional chalk and board for one group while only the traditional chalk and board method was used for the other group. Same question paper was given for both groups at the end. The student's t test was used as the analytical tool to analyze the results. The statistical results confirmed that the used system supported the students to visualize and understand the concepts related to chemical kinetics in a better manner. For this sample, at 95% confidence level t calculated (10.372) is greater than t tabulated (2.048) suggesting that this proposed teaching aid improved the students' knowledge and understanding significantly than that of the ordinary chalk and board method. This developed MS Excel worksheet/system together with its findings will be beneficial to several sectors such as chemistry students, teachers, school administrators and policy makers.

**Keywords**— chemical kinetics, chemistry, MS Excel worksheet, chalk and board method

## I. BACKGROUND, MOTIVATION AND OBJECTIVE

### Background

The approaches of using audiovisual aids to stimulate learning that persists and enabling students to enjoy learning through indirect experience by using audiovisual materials were two research and development areas which were prominently addressed by an exceptional educationist, Edgar Dale [1]. Although he published the concept of "Cone of experience" in 1960s his effort remains to inspire educational technologists in the 21<sup>st</sup> century as well [2]. It is a model that combines several theories related to instructional design and learning processes.

Nowadays, this "learning by doing" has become accredited as "experiential learning".

In moving towards the peak of the Cone from direct experiences to verbal symbols, the degree of abstraction gradually increases. As a result, learners become an audience rather than participants. The bottom of the Cone represented "focused experience" that is encountered by the senses of the body and which is highly effective for the learner. But in contrast verbal symbols (i.e., words) at the top of the cone are highly abstract. Visual receiving like exhibits, demonstrations are placed in the middle with an approximate retention or recall capacity of 50%. It also

suggests that when choosing an instructional method, it is important to integrate the participation of the students to the process which is vital for the successful implementation of a learning activity. Therefore, many educational applications have been created so that the students can learn theoretical concepts through visual and interactive manner.

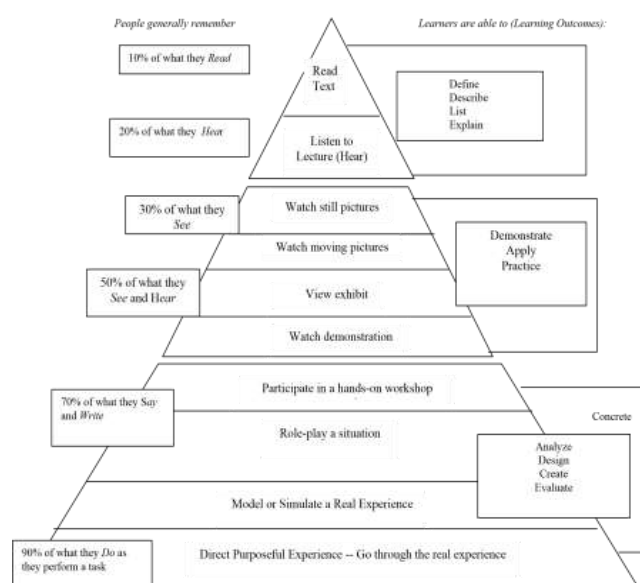

Fig. 1 Dale's Cone of Experience [2]



Utility of the concepts in Dale's Cone in teaching and learning of a science subject like chemistry is phenomenal as it involves the understanding of many abstract concepts. Chemistry which is often said to be the "central science" as it serves as the interface for most other sciences. Chemistry education is an interdisciplinary field which is consisted with all aspects of teaching and learning chemistry. Therefore "purposeful learning" of chemistry is a challenging task. Instructional method plays a crucial role and has a direct link between the problematic concepts and the student's ability to solve them. As a practice most of the chemistry teachers follow a traditional method to deliver the subject content using chalk and board method in a teacher centered learning environment which is not sufficient to arouse the curiosity of the student. In fact, this passive learning approach deserts some of the capable students stranded. Stimulation of the students thinking process through active participation and visualization fascinates young minds enabling them to resonate with their teachers.

Many teaching aids are available these days that can be used for effective instructional process in chemistry. They can be classified as visual aids such as actual objects, models, pictures, charts, maps, flash cards, white board, slides; audio aids like radio, tape recorder and audio-visual aids which includes television, film projector, film strips, multimedia *etc.* Teaching aids are useful in teaching learning process, but they contain some limitations such as: learners may form inaccurate imprints, not giving the full image of a subject, difficulty in identifying key points *etc.* Despite of these insufficiencies teaching and learning of chemistry can be transformed to a highly effective nature when it is combined with appropriate teaching aids.

Abundant means and benefits of using computers and other technological aspects can be recognized for the teaching learning process as a tool, medium and a tutor. Some of them include; instructing the students using power point slides, word documents or web pages and using hyperlinks for better concept clarity; video conferencing, chat and email for better communication, viewing the current syllabus through website of the concerned school board *etc.* The use of MS Excel spreadsheets has been broadly encountered in the educational journals and conferences as one such method. These studies have pointed that due to its wide-ranging capability in processing and presenting data MS Excel program is very useful in chemistry teaching [3]. MS Excel could be used as a teaching tool because of its ability to solve a variety of chemistry problems including calculation and plotting of graphs. Furthermore, both the teachers and students are accustomed to MS Excel software enabling themselves to expand the academic horizons with enthusiasm and understanding. Spheres of chemistry that practice MS Excel include kinetics, titration curves, isothermal gas law and calculations of atom/molecule orbital *etc.*

## Motivation

In Sri Lankan context chemistry is introduced as one of the main science subjects in secondary level of national curriculum. General Certificate of Examination Advanced Level (G.C.E. A/L) Chemistry syllabus recommended by the National Institute of Education (NIE) has been designed targeting to provide basic knowledge required in the subject for higher education in Sri Lanka. Despite of its significance, the performance of the learners in national exams remains low. Some areas of the syllabus like physical chemistry can be recognized as the most challenging for the students to capture deeming least attention. This is evident by the evaluation report for G.C.E. (A/L) chemistry published by the department of examination, Sri Lanka [4]. According to the available research findings poor performance can be attributed to factors such as poor instructional methods, attitudes of the students and teachers towards the subject and lack of resources. Integration of computer technology for the instructional purposes and thereby reinforcing the teaching and learning process of chemistry towards more student-centered approaches could improve students' performance in chemistry. A limited number of investigations were concentrated on this subject matter in Sri Lanka. Therefore, considering the existing gap of research in Sri Lanka an MS Excel worksheet/system was developed and used for the purpose of teaching concepts in chemical kinetics.

## Objectives

One of the objectives of the study was to develop a teaching aid using the inbuilt functions of MS Excel to explain theories in chemical kinetics.

This in turn upgrades the standard of chemistry education by combining it with visually enhanced teaching.

Introduction the created template to chemistry students and teachers and evaluate their acceptance was another objective of the research.

Final objective of the research was statistically analyzing the effectiveness of the system.

## II. STATEMENT OF CONTRIBUTION/METHODS

### A. Statement of Contribution

MS Excel worksheet environment becomes a dynamic and responsive work environment when formulae and functions are used. Most of the research done were allotted with the students' attitude towards the use of new technology. Zain, Rahman and Chin (2013) in their research developed MS Excel worksheets to teach few chemistry lessons selected from physical and inorganic chemistry in the high school and first / second year university syllabi [5]. The survey method was used to obtain the views of the students and teachers regarding the application of MS Excel in their study process.

Akcayi, Durmaz, Tuysuz & Feyzioglu (2003) conducted a study to compare the effects of computer-based learning and ordinary method on students' performance and attitudes in analytical chemistry [6]. From the department of chemistry education at Dkuz Eylul University, Turkey a group of 195 learners were selected randomly and divided into three groups; a control and two experimental. For the purpose of teaching analytical chemistry topics, two different computer-based methods; new learning software called HEHASit and a MS Excel program were prepared by the researchers and applied to the two experimental groups at the same time the control group was taught by the traditional method. An attitude questionnaire and an achievement test related to analytical chemistry were developed and applied to all three groups comparing the outcomes.

Sinex (2007) developed a series of interactive Excel sheets or Exceletes for discovery learning in general chemistry [7]. According to the researcher, when the students were allowed to involve in various Exceletes and associated activities they receive the opportunity of engaging in higher-order thinking and science processing skills. This was done in MS Excel using different formulae. As mentioned Exceletes improve the interactivity to instruction in online classes. Some mathematically advanced topics such as competing and consecutive reactions in organic chemistry can be explored from a conceptual approach.

However, exploring the effectiveness of a developed MS Excel worksheet/system as a visually enhanced teaching method to grasp chemistry concepts in Sri Lanka is not extensive. In this research it was planned to develop an MS Excel worksheet /system as an interactive, visually enhanced quality input, the same was used for the instructional process in teaching chemical kinetics concepts in secondary level and it was compared with the traditional teaching method which was not broadly taken into consideration in the field of chemistry education in Sri Lanka. This study thus attempted to fill these existing research gaps by investigating the effectiveness of the system in teaching and learning of a selected segment of the G.C.E. A/L chemistry syllabi.

## B. Methods

### *Developing an MS Excel worksheet/system to learn concepts in chemical kinetics*

The development of worksheet/system was achieved using the inbuilt MS Excel functions with minor usage of visual basic in MS Excel. In this study it was used as a teaching aid which empowered the students to learn the concepts of chemical kinetics and compared it with the traditional teaching method. The spreadsheet program used was MS Excel 2013. Arrangement of the MS Excel system can be stated as; providing related theory as brief notes (based on the content given in the resource book which was published by National Institute of Education), graphs for zero order reactions, first order reactions, second order reactions,

comparison of graphs of the three orders- variation of reaction rate over the concentration of the reactant, variation of concentration of the reactant over the time and the variation of log rate over log concentration and a practical component with guided questions. In the section of the practical a freely accessible video clip of the practical can be embedded to the system and used prior to the practical as a demonstration. Experimental determination of the effect of concentration on the rate of the reaction between sodium thiosulphate and nitric acid was selected, since it is one of the highlighted practical in the secondary chemistry syllabus, Sri Lanka. They are presented as combined worksheets in the system.

Table I summarizes the basic chemistry equations that were used to create the graphs on zero order reactions, first order reactions and second order reactions. Apart from them units of rate constants are mentioned in each section as numerical or graphical ideas become meaningless without the proper units.

**Table. I Equations used in creating the graphs for the reaction of A → Products**

Order of the reaction	Rate expression*
Zero order	Rate = k [A] <sup>0</sup>
First order	Rate = k [A] <sup>1</sup>
Second order	Rate = k [A] <sup>2</sup>

\* k = rate constant, [A] = concentration of the reactant A

The inbuilt functions in MS Excel permit users to test logical conditions and return a logical result in the form of text or numbers. Elementary logical functions available in MS Excel comprise AND, OR, NOT, TRUE, FALSE, IF, IFERROR *etc.* These were used appropriately along with the chart wizard for the purpose of generating interactive graphs. Active X controls such as command button, spin button and scroll bar (to change the rate constant and to change the order of the reaction) were used for zero order, first order, second order, comparisons and practical sections of the study.

### *Using the template created in teaching chemistry in a classroom setting*

The experimental design used was a proxy pre-test post-test design [8], [9], [10]. This approach is very similar to the standard pre-test post-test control group design illuminating only one difference; the pre-test scores can be collected even after the treatment was administered since it is not the same paper given as the post-test. In this method a pre-test is not actually done but an alternative/ proxy technique is used to represent the first test. The content used in the post-test was based on the concepts presented in the chemical kinetics unit and the students did not have any previous knowledge or experience with the related chemical kinetics concepts before the study. Therefore, using the same post-test question paper as the pre-test to assess the equivalency between the two groups is futile. A meaningful alternative to the pre-test is the immediately previous term test to assess

a newly introduced subject matter. The post- test was introduced just after the treatment in order to avoid any other means in which students gain the concepts regarding the chemical kinetics lessons.

A set of 30 students each who follow chemistry as a subject in Grade 13 (secondary level) were chosen as the sample and randomly divided into two groups (Group 1 and Group 2). Student's t-test at 95% confidence level was used to assess the similarity/homogeneity of the two groups before starting the lessons, taking their final term test chemistry performances into consideration [11]. The purpose of the study was explained clearly to the two groups and obtained their consent and commitment to support the study. Then the chemistry lessons were conducted to give the theoretical understanding regarding the rate law, order of the reaction, zero order reactions, first order reactions, second order reactions, associated graphs *etc.* for both the groups using the same teacher. Students in Group 1 learnt using the adapted MS Excel worksheet approach in addition to the ordinary chalk and board method while the students in Group 2 experienced the same lessons using only the ordinary chalk and board method. At the end of the learning session, same question paper at the competency level similar to that of G.C.E. (A/L) was given to both the groups as the post-test. Answer scripts were assessed by the same examiner and the performances were evaluated by means of statistical test-student's t test.

**A. RESULTS, DISCUSSIONS AND CONCLUSIONS**

**A. Developing the teaching aid**

A user-friendly application was developed. Guidelines are given so that a user who is working with this approach for the first time even can operate it smoothly. The definition of the rate constant and basis of changing it are given as a note, in which the user can see when click on the red colour arrows of the system. Students can observe the changes to the graphs instantaneously when the parameter set (k, rate constant) is being changed. Out of the six sections of the created quality input area of first order reactions with its usage are given below as an example.

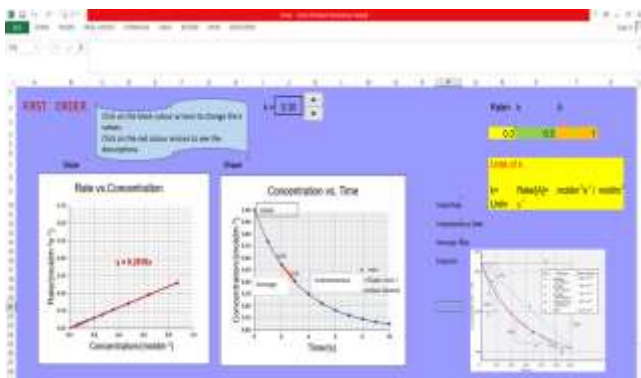

**Fig. 2 Graphical representations for first order reactions**

As mentioned earlier the graphs are interactive. The graph of rate versus concentration for the first order reaction is an upward-sloping line as the rate is directly proportional to the concentration of the reactant. The slope of the graph quantifies the rate constant, k and as rate constant varies the student can visualize the change in the slope and the rates corresponding to different concentrations *vice versa*. As shown, for the first order reaction, the variation of concentration over the time is a curve which indicates the decrease in reactant concentration with time. The units of the rate constants are introduced, Students were given the opportunity to exercise simple calculations associated with rate law which enables them to conceptualize the kinetics basics. The concepts of initial rate, instantaneous rate and average rate also can be introduced using the plot of concentration versus time quickly.

In the similar manner remaining sections are elaborated introducing theories involved, graphs of zero order reactions, second order reactions, comparison of the graphs among the reaction orders and a section for practical and associated problems.

**B. Using the MS Excel worksheet in teaching chemical kinetics in a classroom setting.**

The results of post-test corresponding to the two groups are given in Figure 3.

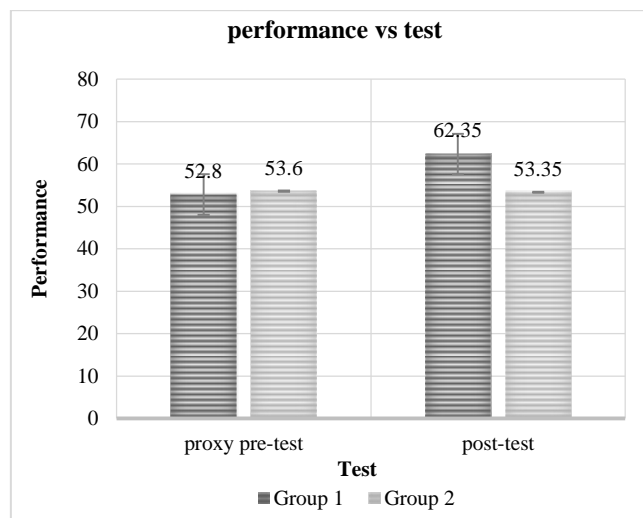

**Fig.3 A column graph of mean for the two student groups based on the test type.**

Figure 3 illustrates that both the students in Group 1 and 2 have similar academic performance at the proxy term test but there is a significant difference in the post-test results. For the proxy term-test, it was noted that  $t_{calculated}$  (1.107) is lesser than the  $t_{tabulated}$  (at 95% confidence level, 2.048) indicating that there is no significant difference between the mean values of the two groups. Thus, the knowledge levels of the two student groups are at the same qualifying to be used as a proxy pre-test. Since teaching method is the only variable in the experimental set up, any significant



difference of the post-test results attributes to the differences of teaching learning practices of the two groups.

**Table II Statistical data for t-test calculations**

	Group 1	Group 2
Mean ( $\bar{x}$ )	$\bar{x}_1 = 12.47$	$\bar{x}_2 = 10.67$
Standard deviation (s)	$s_1 = 2.799$	$s_2 = 2.193$
(s) <sup>2</sup>	$(s_1)^2 = 7.838$	$(s_2)^2 = 4.809$
No: of students (n)	$(n_1) = 15$	$(n_2) = 15$

Statistical data for t-test calculation of the assessment marks are given in Table II. Equations used for student's t-test calculation are displayed as (1) and (2).

$$S_{pooled} = \sqrt{\frac{s_1^2(n_1-1) + s_2^2(n_2-1)}{n_1 + n_2 - 2}} \quad (1)$$

$$S_{pooled} = 0.475$$

$$t_{calculated} = \frac{|\bar{x}_1 - \bar{x}_2|}{S_{pooled}} \sqrt{\frac{n_1 n_2}{n_1 + n_2}} \quad (2)$$

$$= 10.372$$

Mean value of the post-test of Group 1, shows a clear difference. For this, Group 1 mean value is higher than Group 2 mean value and is significantly different at 95% confidence level. Mean values for the post-test for Group 1 and Group 2 are 12.47 and 10.67 respectively (without any conversion). The  $t_{calculated}$  for the mean values (10.372) is greater than the  $t_{tabulated}$  (at 95% confidence level, 2.048) implying a significant difference of the two teaching methods according to student's t test at 95% confidence level. Thus, it clearly demonstrated that the developed MS Excel based teaching tools for conceptualizing the teaching of chemical kinetics is very effective compared to traditional method.

These results can be combined with the explanation of Dale's cone. Accordingly, students in Group 1 did the lessons with exhibits/with the application (visual receiving). They gained knowledge through 'see' and 'hear' both. This experience allows students to see the meaning and relevance of concepts based on the different pictures and representations presented. Here, they achieve the learning outcomes like demonstrate, apply and practice. The bottom of the Cone represents "focused experience" that is encountered by the senses of the body and which is highly effective for the learner. Since Group 1 learn through an interactive platform they are in a state of moving down in the Cone having "focused experience" as well. Students of Group 2 gained knowledge mostly through hearing (verbal symbolic) only. The cone displays the average retention rate for various methods of teaching. Students tend to remember 50% of what they 'see and hear'. When the students were tested after the lesson Group 1 performed better as they understood better by a visually enhanced method.

## Conclusion

A novel computer assisted, MS Excel application has been designed to teach chemical kinetics concepts allowing the students to gain better understanding of the lesson visually. It is a simple and user-friendly approach that can be used for secondary level students to explain basic concepts in chemical kinetics. The MS Excel application will allow the students to visualize theories such as rate law, order of the reaction, variation of graphs with their underpinning concepts, information which can be obtained from graphs and the practical aspect of chemical kinetics easily.

In order to study the effectiveness of the application in the teaching learning process, same chemistry lessons were taught to two groups of high school students; using the developed application as a teaching aid along with the traditional chalk and board method for one group and only through the chalk and board method for the other group. Mean marks of the group who were taught using the MS Excel application in addition to the chalk and board method was significantly higher at 95% confidence level using the student's t test.

As a consequence, it can be concluded that this proposed teaching aid, MS Excel worksheet improved the students' knowledge regarding chemical kinetics significantly than that of the traditional teaching method. The application together with the teacher's instructions given can be used by the students to achieve the competency level expected in chemical kinetics to secondary level students

This quality input would be useful for chemistry teachers and learners in their teaching learning process. Since this is a user-friendly application, students can use it a self-study material and a revision guide as well. These findings of the study would be an eye-opener for school administrators in order to improve the infrastructure necessary for such implement and also for policy makers when preparing curriculum upgrading and reforms.

Teaching Chemistry is not limited to the few methods that are used now but rather it is a broad concept that includes all the media that we can use to attain a balance as we facilitate effective and meaningful learning. Therefore, it is evident that MS Excel worksheet (system) created can be utilized to conduct chemistry lessons to the students in a more effective manner.

## REFERENCES

- [1] Dale, E., "Building a learning environment". Bloomington, IN: Phi Delta Kappa Foundation, 1972.
- [2] Dale, E., Audiovisual methods in teaching, 3<sup>rd</sup> ed.. New York: Dryden Press, 1969.
- [3] Bharathy, J. B., "Importance of computer assisted teaching & learning methods for chemistry". *Science Journal of Education*, vol.3(4), pp.11-16, 2015.
- [4] Examination department, Chemistry Evaluation Report - G.C.E. (A.L.) Examination - 2016. Sri



- Lanka, Research and Development Branch, Ministry of education, Sri Lanka, 2016.
- [5] Zain, S. M., Rahman, N. A. and Chin, L. S.,” The teaching and learning of chemical kinetics supported with MS Excel”. Journal of Science and Mathematics Education in Southeast Asia, vol.36(1), pp. 65-85, 2013.
- [6] Akcay, H., Durmaz, A., Tuysuz, C. and Feyzioglu, B., “Effects of computer based learning on students' attitudes and achievements towards analytical chemistry”. Turkish Online Journal of Educational Technology, vol.5(1), 2006.
- [7] Sinex, S. A., “Chemical spreadsheet investigations: Empowering student learning of concepts via camouflaged mathematical exploration”. Using Computers in Chemical Education Newsletter, 2007.
- [8] Moore G., “An empirical test of design patterns for children's environments, People and the physical environment research”. Wellington, New Zealand: Victoria University of Wellington, 1983.
- [9] Trochim W. and Donnelly J. P., “The research methods knowledge Base”, 3<sup>rd</sup> ed, Mason, OH: Thomson Publishing, 2007.
- [10] Carbonell P., “Quasi and experimental research designs, Interdisciplinary review of research and development”, vol. 1(1), pp. 5–11, 2012.
- [11] Harris, D.C., “Quantitative Chemical Analysis”, 8<sup>th</sup> ed.; W.H.Freeman & Company: New York, pp. 73-78, 2010.

# Relevance of Zero Trust Network Architecture Amidst and It's Rapid Adoption Amidst Work From Home Enforced by COVID-19

**Dr. Aniket Deshpande**

Sales Engineering, Zscaler Inc., Singapore  
Email: anik.deshpande@gmail.com

**Abstract**— As organizations evaluate different methods to improve data security, they have to shift to find the best alternative means to secure the servers. Zero Trust Network Architecture (ZTNA) has become the focus of many institutions to prevent data loss, especially from the employees working remotely due to the spread of Covid-19, requiring people to keep social distance minimize risks of an attack. Zero trust employs a multifactor authentication process that requires all users to verify their identity or the device they are using before using a network. This security procedure has been useful in eliminating the castle-and-moat concept's weaknesses that were initially used and could allow an individual to navigate freely through a network once they penetrated the firewall. The Zero trust does not allow the penetration and further segment of different materials; therefore, an individual cannot access all materials once in a network. This cybersecurity method will be advantageous post COVID-19 to deliver a simplified user experience enabling them to manage and find the contents with ease. For the customers, the architecture creates a uniform platform that can be used to amplify the security. The technology is a must for cost-benefit analysis for every organization considering its potential to help avoid potential security and financial losses.

**Keywords**— ZTNA, Network Security, Cloud Security, SASE, Cybersecurity, Securing Work-from-Home, Covid-19

## I. INTRODUCTION TO ZERO TRUST NETWORK ARCHITECTURE

Cybersecurity is a meaningful discussion that should engage all organizations that handle critical information. Both private and government institutions are at risk of losing important data that either belongs to the institution or their respective clients. As a result, many companies are focused on implementing a network security structure that will provide the ultimate data security within their organization. Traditionally, the company's used built firewalls that allowed employees to operate their computer behind the firewall, preventing unauthorized intrusion. However, this network security method has proved to be very challenging in recent months due to the new guidelines that require the organization to shift to a remote workforce. During the onset of Covid-19, governments introduced protocols that aimed at reducing the spread of the virus. For this reason, the organization resolved to work from home (WFH) programs that do not support the use of firewalls, therefore leading to increased rates of attack. According to Mandal & Khan (2020), with growing Covid-19 cases and adherence to the procedures, several cloud mediums have been affected[1]. The attack of cyber threat will also tremendously increase if a similar trend of WFH is strictly followed. Mandal & Khan (2020) further say that network breaches are a major weakness in remote operation as an individual organization has no control over the internet sources used by their employees[1]. Therefore, logging in to unprotected servers enables hackers to access information stored in the computers or company systems easily. The security concern is a primary issue to all

institutions; therefore, threats that arise due to the work from home scenario must be keenly taken into consideration. Verizon's survey says that 474 data breach cases were reported across the world, with 80% from March to June, and these intrusions were caused by hacking, stealing of data, and brute force attacks[2]. These statistics show the need for a new method of cyber protection. Therefore, a zero-trust network architecture is the most appropriate due to its ability to provide protection even for computer users logged into a private network.

## II. WHAT IS THE TRUST NETWORK ARCHITECTURE?

Zero trust security is an information technology (IT) data protection model that requires strict identification verification for every person or technological device that attempts to access any resource on a private network[3]. Moreover, the verification procedure must be followed whether the access request is within or outside the network parameter. Cloudflare<sup>(R)</sup> (2020) further states that there are no specific technologies associated with Zero Trust Architecture[3]. It is a holistic approach to the network security system incorporating a wide range of principles and technologies. This modern IT network security dramatically differs from the traditional methods used to secure information in various servers. For instance, pre-modern technology is based on the castle-and-moat concept, which prevents unauthorized access from outside the network but enables access to people within the network. Still, devices found inside a particular network are trusted by default. With Zero Trust security, no user is trusted by default, whether from outside or inside a

network. Every individual must have the right credentials to access the resources within it. Traditional network security systems had one primary vulnerability: once an attacker gains access to a network, they are free to reign over everything. According to DeCusatis et al. (2016), the fundamental principle of Zero Trust involves guaranteeing secure access to all resources regardless of the device's location with the assumption that the persons trying to access these materials are a threat until authorized, inspected, and secured[4]. Therefore, a company can easily partition the resources that need to be protected to prevent unauthorized personnel access.

### III. VARIOUS INTERPRETATIONS OF ZERO TRUST NETWORK ARCHITECTURES

Zero Trusts rely on several preventive techniques to provide the needed network security within the enterprises. Firstly, the model uses multifactor authentication (MFA) to confirm the user's identity and improve a network's safety[5]. MFA uses a complex security protocol, including posing certain security questions, automatically sending email or text confirmation messages to users trying to enter a network, or the logic-based exercises to assist in assessing user's credibility. Different companies use divers' authentication factors depending on the level of security that is required. Besides, the inclusion of more authentication points is critical for the strong overall security of a company. Secondly, least privilege access is another interpretation that is used to reinforce cybersecurity using Zero Trust. This method implies that the organization gives each user or device the lowest possible access to the network. This procedure will prevent lateral movement and the network in case of a breach, therefore minimizing the surface for attack. Thirdly, this model uses a micro-segmentation technique that entails dividing the parameters into small parts to maintain access to every network zone. This technique ensures that in case of insecurity, the hacker may not go beyond the microsegment. Even though the three techniques provide security, they are applied differently, and every organization can choose the preferable method to ensure the safety of their data. However, the application of all methods is essential for a reliable security system.

### IV. NIST FRAMEWORK FOR ZTNA

The NIST security framework guides organizations on critical infrastructures. This guideline is categorized into five essential functions, such as identification, detection, protection, response, and recovery[6]. The framework is flexible and easy to integrate into security systems that are used in any organization. Therefore, before implementing any information security such as ZTNA, the NIST framework provide the recommended baseline that should be followed by organizations. Based on the NIST framework, before executing the ZTNA, an organization needs first to identify its most valuable asset and resources. The organization should then apply relevant safeguards and

methods of protecting the critical infrastructure, such as data security and protective technology. The procedures selected should have the ability to alert the organization in case of a cyberattack, and the systems should respond appropriately to avoid any forms of attack. Lastly, recovery activities assist in maintaining resilience and ensuring business continuity in the event of an attack.

In adherence to the NIST framework, Zero trust is designed to specifically focus on resource and data protection in cases where this material requires any form of identity[6]. With the implementation of Zero trust, resources are only available to people in need, and privileges are very limited. Once employees need any material, they are granted access through a policy decision point and policy enforcement point. Zero trusts have particular logical components that can be operated within the enterprise premises and as cloud-based services (Rose et al., 2019). Every component plays a specific role in maintaining a stringent security network. For instance, a policy engine is useful for permitting users to resources; policy administrates limits communication between a user, and the resource and policy enforcement point can enable, monitor, and further terminate the access of any resources belonging to a company. The policy engine uses the trust algorithm not only to permit users but also to lock them out of using the materials. The policy engine use has a wide range of inputs to assist in the adequate performance of the trust algorithm. For instance, access request input determines whether the security system approves the application, device, or user requesting the source. Five inputs perform a different function to uphold the best security standards. These are asset requests, subject database and history, asset database, resource policy requirements, and threat intelligence and logs.

### V. VARIOUS INTERPRETENCE OF ZERO TRUST ARCHITECTURES

Different companies have instantiated for varied domains when implementing Zero Trust Network Architecture. For instance, Microsoft uses ZTNA to ensure strict adherence to corporate and customer data[7]. Moreover, this model is used to deliver a simplified user experience enabling them to manage and find the contents with ease. For the customers, the architecture creates a uniform platform that can be used to amplify the security.

The picture below (Figure 1) shows the Zero Trust scope and phases created by Microsoft to guide the new security model's implementation. Figure1 clearly indicates the roadmap organized based on phases, which includes goals and the current security status. Before the outbreak of Covid-19, many organizations used parameter security systems, characterized by a lack of proper device management, a single-factor authentication process, and the capability to enforce a strong identity. Figure1 further shows how Microsoft has emphasized identity-driven security solutions and centres through the robust MFA

process. This is a simple scope that can be adopted by small and large enterprises effectively to ensure excellent data security using the Zero Trust model.



Figure 1. Zero Trust scope and phases created by Microsoft[7]

Figure 2 shows a simplified reference architecture that was used by Microsoft to implement a Zero Trust. The critical components of this procedure are device management and device configuration requirements. The company Azure Active Directory (Azure AD) performs device health validation and is also used for user and device inventory. Microsoft employs this security system to ensure the configuration requirement of the devices. The screened devices then generate statements of health, which are stored in the Azure AD. Upon the user's request to access specific sources, the health of the devices is verified to enable authentication.

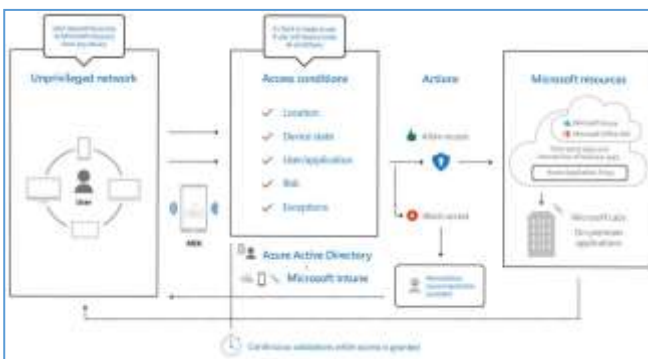

Figure 2. Simplified Microsoft Proposed Zero Trust Reference Architecture[7]

Figure 3 shows how Zero Trust can be implemented in combination with the block-chain model. Block-chain is usually used to maintain decentralization and immutability of data, while Zero Trust principles are used for access control and authorization. Therefore, a company that uses a block-chain can easily incorporate Zero Trust for effective data protection[8]. An interpretation of this diagram shows that most institutions will implement ZTNA regardless of the type of services they offer and the working framework. Therefore, it is essential to find the best way to incorporate the ZTNA into the existing business model.



Figure 3. ZTNA with Blockchain (courtesy Sultana et al. 2020)

### VI. POTENTIAL COST-BENEFIT ANALYSIS TO ADOPT ZTNA

According to Froehlich (2020), ZTNA is an excellent investment against stolen data, and institutions should regard this as investment capital if the information of a company is stolen[9]. Froehlich (2020) further states that the cost of a single data breach is approaching \$4 million; therefore, implementing a Zero Trust cybersecurity framework to prevent information loss and further avoid loss of capital should be considered a good investment by an organization[9]. Generally, depending on the type of company, an organization can incur massive losses due to hacking. For instance, financial and insurance companies will directly lose capital through hacking if there is a data breach.

### VII. GARTNER SASE FRAMEWORK AS AN OVERLAPPING CONCEPT TO ZTNA

Secure access service edge (SASE) is a security framework that allows safe and fast cloud adoption. Moreover, this security framework ensures that users and devices have secure cloud access to applications, data services at any place, and any time. SASE effectively combines network security functions such as SWG, CASB, FWaaS, and ZTNA with WAN to support an organization's dynamic security needs. SASE provides real-time context and security and compliance policies upon assessing the entity's identity when delivering security services using ZTNA, SWG, CASB, and other capabilities. Generally, SASE is a technological package that includes ZTNA as its core capabilities. For this reason, SASE can easily provide network security by determining the identity of the user, device, and application. Moreover, ZTNA also follows NIST SP 800-63-3 digital identity guidelines and integrates the agency's ICAM policy making it one of the best security protocols not only for remote workers but also for employees working within specific organizations[10]. Implementing ZTNA in line with the NIST framework ensures that data privacy risks and mitigation factors are considered before its implementation process, therefore making it more suitable for any organization.



### VIII. COVID-19 PANDEMIC AND IMPACT ON ADOPTION OF ZERO TRUST NETWORK ARCHITECTURES

#### A. Fast-tracked emphasise on adoption due to COVID-19

Zero Trust Network Architecture has gained popularity among diverse companies since the first case of Covid-19 was reported. According to Hope (2020), as many small and medium organizations moved towards remote working, many firms were looking for alternative ways to solve their legacy security practices, which did not support the WFH[11]. As a result, Zero Trust was highly embraced by the IT experts to be one of the best methods to secure valuable company resources and prevent hackers from obtaining important information that belongs to the company or their clients. Hope (2020) acknowledges that many firms were not adequately preparing for cloud transformation during the virus attack. For this reason, cybersecurity departments scrambled to configure their network parameter for remote access by their employees[11]. Despite a lack of proper security preparedness, maintaining the right network protection proved difficult, especially for those using other methods such as firewall security system forcing most employers to undergo cloud transformation. As a result, the firms accelerated their shift to the Zero network framework. Hope (2020) says that 76% of the polled companies, to determine their preparedness to adopt new systems that could offer stringent security measures, were using outdated methods to protect their data[11]. The organizations using the old fashioned processes needed to adapt the Zero Trust Architecture quickly. The research further indicates that 82% of the organization surveyed during the pandemic was more committed to implementing ZTNA to enable employees to operate remotely with cybersecurity challenges. One of the major difficulties reported among the organization adopting this new criterion was Identity and Access Management (IAM). IAM is essential for informing all network users of some of the things they are allowed to do and something they cannot do in a network.

Research by McGillicuddy (2020) states that 61% of the firms that shifted to ZTNA lead to improved security issues[12]. Many organizations have experienced a surge in the number of devices penetrating their networks; therefore, adopting the Zero Trust system has been critical for improved data security for the affected firms. Moreover, ZTNA provides companies with an opportunity to allow employees to use their devices without the risk of hacking. ZTNA has a wide range of benefits to users and specific companies that have employed it. For instance, network security architecture allows employees to access the web despite their remote location directly. Users can easily connect with the applications, and the traffic flows along the shortest secure path. This security system also improves context-awareness by enabling users only to see what they should see. Context-awareness can be more beneficial in

scenarios other than just working from home security. Mergers and acquisitions, cloud migration, and third-party access are some of the essential advantages that enterprises stand to enjoy even when this system is implemented post-Covid-19. Challenges that might be experienced in this situation can easily be addressed through user-centric policies. Moreover, ZTNA enhances greater visibility by allowing companies to know who is accessing what, and where, anywhere in the network, which is very beneficial for remote working and even in a situation where employees need to work from one central location.

#### B. Continued Adoption of ZTNA Post COVID-19

The Castle-and-moat approach used by different enterprises has proved to have a wide range of security vulnerabilities. Firstly, the Castle can allow any individual who has penetrated the firewall to freely operate within a network since there are no additional security measures. Several studies have revealed that the Castle no longer exists in isolation as it once did. Secondly, the information technology world is shifting towards cloud and mobile platforms; therefore, many users need quick access to different applications and data from various devices and multiple locations. Moreover, companies are dealing with distributed information infrastructure, which is very challenging to secure with a perimeter-based approach. Therefore, the Zero Trust model is essential for the identification of users, devices, and applications that are on a network. Besides, companies can easily employ policy rules using a role-based approach[13]. Institutions can also grant appropriate network access to specific users, devices, and applications and further segment the data based on its type, sensitivity, and use. This procedure ensures that Zero Trust is used to protect critical information within an organization, and the surfaces that are more prone to cyber-attacks are reduced drastically. Even though Zero Trust has been useful in improving security for employees working remotely, the model will be equally crucial for securing materials that are accessed within the institution. Moreover, it limits the chances of attack even when hackers have penetrated the firewall and other parameter security systems, making it more important to protect company data even post COVID-19. Implementation of the Zero Trust model guarantees an excellent security orchestration by ensuring no holes are left uncovered. The combined security elements complement one another, protecting the institution's valuable information.

### IX. CONCLUSION

A wide range of organizations has adopted ZTNA during this pandemic to ensure information security and reduce the increasing rate of data loss. Besides, it is essential to note that ZTNA has been crucial even in workers' remote locations, especially in areas where the parameter security system cannot be used. ZTNA eliminates cybersecurity weaknesses that are present when using the firewall

method. For instance, segmentation of the network to prevent a hacker from navigating through the entire system once they penetrate the firewall. With the old system, any individual who has penetrated the firewall can easily access resources within a network. ZTNA will require authentication for any user or device, therefore preventing these risks.

## REFERENCES

- [1] S. Mandal and D. A. Khan, "A Study of Security Threats in Cloud: Passive Impact of COVID-19 Pandemic," in *Proceedings - International Conference on Smart Electronics and Communication, ICOSEC 2020*, 2020, pp. 837–842.
- [2] "COVID-19 Data Breach Landscape | Verizon Enterprise Solutions," *Verizon Inc.*, 2020. [Online]. Available: <https://enterprise.verizon.com/eng/resources/articles/analyzing-covid-19-data-breach-landscape/>. [Accessed: 20-Dec-2020].
- [3] "Zero Trust Security | What's a Zero Trust Network? | Cloudflare UK," *Cloudflare Inc.*, 2020. [Online]. Available: <https://www.cloudflare.com/en-gb/learning/security/glossary/what-is-zero-trust/>. [Accessed: 20-Dec-2020].
- [4] C. DeCusatis, P. Liengtiraphan, A. Sager, and M. Pinelli, "Implementing Zero Trust Cloud Networks with Transport Access Control and First Packet Authentication," in *2016 IEEE International Conference on Smart Cloud (SmartCloud)*, 2016, pp. 5–10.
- [5] "Zero Trust Security Explained | Principles of the Zero Trust Model," *CrowdStrike Inc.*, 30-Apr-2020. [Online]. Available: <https://www.crowdstrike.com/epp-101/zero-trust-security/>. [Accessed: 20-Dec-2020].
- [6] National Institute of Standards and Technology, "Zero Trust Architecture - Draft (2nd) NIST Special Publication 800-207," p. 49, 2020.
- [7] "Implementing a Zero Trust security model at Microsoft," *Microsoft Corporation*, 2020. [Online]. Available: <https://www.microsoft.com/en-us/itshowcase/implementing-a-zero-trust-security-model-at-microsoft>. [Accessed: 20-Dec-2020].
- [8] M. Sultana, A. Hossain, F. Laila, K. A. Taher, and M. N. Islam, "Towards developing a secure medical image sharing system based on zero trust principles and blockchain technology," *BMC Med. Inform. Decis. Mak.*, vol. 20, no. 1, p. 256, Oct. 2020.
- [9] A. Froehlinch, "The 6 benefits of zero-trust security for businesses," *TechTarget*, Oct-2020.
- [10] S. Rose, O. Borchert, S. Mitchell, and S. Connelly, "Zero Trust Architecture," Gaithersburg, MD, Aug. 2020.
- [11] A. Hope, "COVID-19 Pushed Most Firms To Adopt Zero Trust Security Model, a New Study Found - CPO Magazine," *CPO Magazine*, 19-Oct-2020.
- [12] S. McGillicuddy, "Survey: Zero Trust benefits remote work during pandemic | Network World," *Network World, IDG Communications, Inc.*, 28-Oct-2020.
- [13] J. Kindervarg, S. Balaouras, and K. Mak, "Build Security Into Your Network's DNA: The Zero Trust Network Architecture," *Forrester Inc.*, 2012. [Online]. Available: <https://www.forrester.com/report/Build+Security+Into+Your+Networks+DNA+The+Zero+Trust+Network+Architecture/-/E-RES57047#>. [Accessed: 20-Dec-2020].

# Compared And Properties Of Oil Palm Empty Fruit Bunching Fibers To Be Used As A Roofing Material

<sup>[1]</sup> Kittisak Buasri, <sup>[2]</sup> Prayoon Surin

<sup>[1]</sup> Department of Advanced Manufacturing Technology, Faculty of Engineering, Pathumwan Institute of Technology, Wangmai, Pathumwan, Bangkok, Thailand

<sup>[2]</sup> Department of Industrial Engineering, Faculty of Engineering, Pathumwan Institute of Technology, Wangmai, Pathumwan, Bangkok, Thailand

Email: <sup>[1]</sup> me.\_ie.\_eng.55@hotmail.com, <sup>[2]</sup> prayoon99@gmail.com

**Abstract**— The objective of this research is to study the Compared and Properties of Oil Palm Empty Fruit Bunching fibers used as a Roofing Material. The roofing sheet material is produced like a corrugated. Regarding the process of producing, they use synthetic adhesive Polymeric Diphenylmethane Di-isocyanate resin (pMDI) , Urea formaldehyde resin (UF) and synthetic adhesive Phenol formaldehyde resin (PF), 5% and 10 wt%. The roofing sheet material has a density at 700 kg m<sup>-3</sup> and 15 mm. thickness. After that, it is tested for physical, mechanical and Thermal properties, according to the Industrial Standards of TIS.876-2547, TIS 535-2556, JIS A 5908-2003 (8 type), ASTM D 256-2006a. The thermal properties are also tested, according to ASTM C 177-2010. The study reveals that oil palm empty fruit bunching fibers used as a roofing material can be pressed into an corrugated roofing material. They have required physical the properties, and mechanical the properties meet the Industry Standard TIS 876-2547 and TIS 535-2556. The properties taken into consideration are; a density, moisture, water absorption, water leakage and thickness swelling, modulus of rupture and modulus of elasticity resistance and impact strength. According to the study using three types of adhesives, it is found that synthetic Polymeric Diphenylmethane Di-isocyanate resin provides the best mechanical properties. For the thermal the properties, it is found that the thermal conductivity and resistance of the roofing sheet material use urea formaldehyde resin (UF) is better than the properties.

**Keywords**— Empty Fruit Bunching fibers, Physical properties, Mechanical properties, Thermal properties

## I. INTRODUCTION

Thailand is one of the countries that has a lot of agricultural waste materials. However, such materials are rarely re-used and are neglected on cultivation areas which ends up being burnt. At present, agricultural waste materials are scattering all over the country, depending on agricultural product quantity of each particular area. The most agricultural wastes contain 3 main types of organic chemical components is cellulose, hemi-cellulose, and lignin In the ratio of 4: 3: 2 Kuhad, R.C. [1] In the past, it was found out that there were a lot of waste materials more than 43 million tons/year. S.Tengkaew. et.al. [2] Such agricultural waste materials with huge quantity are sugarcane and oil palm empty fruit bunching fibers. It composes of gathering fiber which can divide into single one. Some are used to get benefit and become approach to develop new products of industrial sectors. P.Wangwan.et.al.[3] Oil palm empty fruit bunching fibers is a kind of agricultural waste material with high nutritional value, compared with fresh grass. However of materials have high quantity and very low value, these waste materials are suitable to use as low materials to produce roofing Material.

The researchers are interested in taking agricultural waste materials i.e. Empty Fruit Bunching fibers to mix with adhesives. Then, the materials are formed into corrugated roofing sheet. Using local materials can generate great

benefits. It is also considered as adding value to natural waste materials. The researchers study how to produce corrugated roofing sheet materials made from oil palm empty fruit bunching fibers. Regarding the adhesives, they use synthetic adhesive Di-isocyanate resin (pMDI), Urea Formaldehyde (UF) and synthetic adhesive Phenol-Formaldehyde (PF) 5% and 10%. Then the three types of adhesives are compared with same quantity. After that the material is formed with 15 mm. thickness. Total hot compress duration is set for 15 minutes with 120 °C. The pressure of hot compression is 150 kg sq-1 centimeters. The outcome product of corrugated roofing sheet is set in 15 minutes with a pressure of 150 kg sq-1 centimeters, at temperature of 120 °C. If the standard is higher than this, the board will deteriorate. Finally, it is tested for physical, mechanical, and thermal properties, according to the industry standard.

## II. REVIEW OF LITERATURE

From past research studies of compared and properties of oil palm empty fruit bunching fibers used as a roofing material

A.Pasilo.et.al.[4] studied the investigation of the properties of roofing tiles manufactured from agricultural residues. The agricultural residues in this work are corncob fibre, plam fruit bunch fibre and water hyacinth fibre. Synthetic urea formaldehyde resin adhesive was selected as

the binder. Main properties of roofing tiles investigated in this work were physical, mechanical and thermal properties. Consequently Finally, it was found that the properties of roofing tiles constructed in this work are similar to commercial roofing tiles.

Jessada W.O.et.al.[5] stated that mechanical and physical properties of roof Tile prepared from sugar cane fiber, sugar cane, renewable fiber resources, were used for roof tile production. Urea formaldehyde, phenol formaldehyde and isocyanate resin were used as binders in this study. Roof tile specimens with 400 mm wide, 400 mm long and 5 mm thick were prepared by compression molding.

Jacob O.A.et.al.[6] have development of roofing sheet material using groundnut shell particles and epoxy resin as composite material. Sample A and B have the best possible proportion to be taken into consideration for the production of commercial roofing sheets. Sample "A" was adopted in this work because of its excellence performance properties. The results revealed that groundnut shell particles can be used as reinforcement for polymer matrix for the production of roofing sheets.

Darsana P.R.A,et.al.[7] have development of coir-fiber cement composite roofing tiles. In order to optimize the cost of construction, engineers have always been on the lookout for efficient and light roofing which requires minimum maintenance and labor to install. Coir is a green building material and has potential as a raw material for the production of roofing materials like corrugated sheets and tiles.

Santhosh B.S.et.al.[8] studied the strength of corrugated roofing elements reinforced with coir. Roofing sheets were casted with flyash- based coir fibers and are experimentally evaluated for the strength of the corrugated sheets in terms of flexural and impact load. Flyash based coir fibre has witnessed improved result in the strength of the corrugated roofing sheets due to flexural and impact loads as compared to the corrugated sheets without coir fibers. The Result of study revealed that the fly ash with coir fiber can be used to replace asbestos in production of corrugated roofing sheets

### III. METHODOLOGY

#### 3.1 Preparing the Fibers Material

In preparing the roofing sheet fiber, oil palm empty fruit bunching fibers received from Oil Palm industry in Surat Thani Province, Thailand. The oil palm empty fruit bunching fibers were washed in water then treated by alkalization using sodium hydroxide (NaOH, provided by company in Thailand) for 24 h. The treated fibers were cleaned by water, dried, cut and ground to fine fibers. The ground fibers were sieved to an average particle size of 5 mm. shown in Fig 3.1



**Fig 3.1 Hammer mill machine to crush oil palm empty fruit bunching fibers**

#### 3.2 Chemicals used in the experiment

Reaction Catalyst: This type of chemical is the accelerator of the reaction rate of adhesive solidity. It can reduce the time period of hot compressing. There are three types i.e. Common catalyst and Latent catalyst. The three types of catalyst are mixed with adhesives to accelerate the materials as soon as the materials get heat. Such catalysts mixing in general glue are; ammonium sulfate, ammonium chloride, and sizing agent which helps reducing water absorption. In addition, paraffin emulsion is used in the study. The researchers also use adhesive Di-isocyanate (pMDI), Urea formaldehyde resin and synthetic adhesive Phenol formaldehyde resin for the experiment.

#### 3.3 Materials and Research Equipment

The research equipment used are as follows; steel mold size of 300×320 mm shown Fig.3.2, wood frame of 300×320mm, digital Vernier caliper which can measure in details of 3digits. Also, the equipment include micrometer which can measure in details of 1.01 mm, and weight scale which can measure in details of 0.001 g.

#### 3.4 Specimen preparation

For the test specimen's preparation, the corrugated roofing sheet material were cut into the exact dimensions described in related standards. The specimen for physical, testing samples density, moisture content (MC), water absorption (WA), thickness swelling (TS) was 50x50 mm and water leakage 300x320 mm samples. The specimen for mechanical properties testing was 50x50x15 mm. The specimen with the dimensions of 12.70±0.20 mm wide by 63.50±2.0 mm long and 6 mm thick was prepared for impact strength test. For modulus of rupture (MOR) and modulus of elasticity (MOE) test, the specimen was 50x200 mm. Sample of 300x300 mm were used to test the thermal and resistivity conductivity.

#### 3.5 Experimental Procedure

First, the researchers use hammer mill machine to crush oil palm empty fruit bunching fibers. The materials are crushed and then become smaller. Then, they are sifted in order to split size by screening machine with grills. The fiber bunches that have been crushed. To analyze the size of oil palm empty fruit bunching fibers used in the extrusion of roofing sheet materials. It was found that the pieces of oil palm bunches that remained on the 40 strains were the highest by 71.18%, with the average width of 0.72 mm., The average length was 4.77 mm. Average thickness is 0.17



mm and the proportion is slim at 27.93 of slender as much. The humidity of both oil palm empty fruit bunching fibers before mixing adhesive is 3.5%, and 10–12% after mixing. After that 1% of paraffin emulsion and 2% of catalyst are infused in the materials. Then, the researchers prepare to form the board by cold pressing method. They sprinkle the fiber with adhesives and other mixture into wooden box of 300×320 mm then, they put the sheet on hot compressors. It is the process of hot pressing by hydraulic compressor set. After hot pressing, the sheet is adjusted moisture condition at the room temperature for 24 h. After adjusting the sheet's temperature, 4 edges are cut. To get standard size, each edge is cut off 1.5 cm by sawing machine. Finally, the sheet or board is tested for physical, mechanical, and thermal properties, according to the industry standard. shown in Fig 3.2



Fig 3.2 Roofing sheet material from oil palm empty fruit bunching fibers

IV. RESULTS AND DISCUSSIONS

According to the process, the researchers form a sample of roofing sheet material from oil palm empty fruit bunching fibers. The size is 15 mm thick. The duration of hot compressing is 15 minutes with 120 °C temperature. The pressure of hot compressing is 150 kg cm<sup>-3</sup>. Then, sample is tested according to the industry standards of TIS. 876-2547[9], TIS. 535-2556,[10] JIS A 5908-2003(8 types) [11], ASTM D 256-2006a [12], and ASTM C 177-2010[13]

4.1 Results of Physical Properties

It is found that the physical properties of the roofing sheet material from oil palm empty fruit bunching fibers compose of density, moisture content, water absorption for 2 and 24 h, water leakage for 2 h and thickness swelling for 2 and 24 h, according to the industry standard.

Table 4.1 Details of Testing an roofing sheet material from oil palm empty fruit bunching fibers

Type and Quantity of Adhesives (%)	Average Density (kg m <sup>-3</sup> )	Symbols
Di-isocyanate resin (pMDI 5%)	763.45	a
Di-isocyanate resin (pMDI 10%)	786.61	b
Urea formaldehyde resin (UF 5%)	761.49	c
Urea formaldehyde resin (UF 10%)	775.95	d
Phenol formaldehyde resin (PF 5%)	756.73	e

Phenol formaldehyde resin (PF 10%)	767.84	f
TIS 876-2547	400-900	g (standard)
JIS A5908-2003 (8 Type)	400-900	

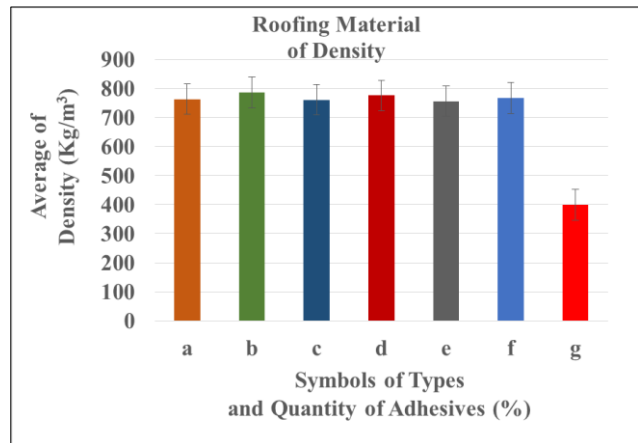

Fig 4.1 Average of density

The study shows that the roofing sheet material from oil palm empty fruit bunching fibers with synthetic adhesive at 5% and 10% phenol formaldehyde resin has average density at 756.73 and 767.84 kg m<sup>-3</sup>. Synthetic adhesive isocyanate resin has average density at 763.45 and 786.61 kg m<sup>-3</sup> respectively. Regarding the corrugated roofing sheet material with synthetic adhesive urea-formaldehyde resin, the average density is found at 761.49 and 775.95 kg m<sup>-3</sup>. Similarly, the roofing sheet material from oil palm empty fruit bunching fibers respectively. The roofing sheet material from oil palm empty fruit bunching fibers can pass the standard level of TIS 876-2547 which defines the density value at 400-900 kg m<sup>-3</sup> show Fig 4.1.

It is found that the moisture content of the roofing sheet material from oil palm empty fruit bunching fibers with synthetic adhesive at 5% and 10% of phenol-formaldehyde resin consists of average moisture content at 12.15 and 11.14%. And the roofing sheet material from oil palm empty fruit bunching fibers sheet with synthetic adhesive isocyanate resin contains average moisture content at 10.42 and 9.91% respectively. Whereas the sheet with synthetic adhesive urea-formaldehyde resin has average moisture content at 10.57 and 9.94 % respectively. The value can pass the standard level of TIS 876-2547 which defines the moisture content at 4-13%. show Fig 4.2.

In terms of water absorption for 2 and 24 h, the roofing sheet material from oil palm empty fruit bunching fibers with synthetic adhesive at 5% and 10% of phenol-formaldehyde resin has average of water absorption for 2 h at 13.25 and 41.21%, and for 24 h at 41.21 and 39.12%. Similarly, the roofing sheet material from oil palm empty fruit bunching fibers sheet with synthetic adhesive isocyanate resin contains average of water absorption for 2 h at 12.22 and 33.74%, and for 24 h at 11.71 and 31.92 %

respectively. However, the sheet from oil palm empty fruit bunching fibers with synthetic adhesive urea-formaldehyde resin has average of water absorption for 2 h at 12.75 and 11.94%, and for 24 h at 38.83 and 35.62%. respectively. The value meets the standard level of TIS 876-2547. The value can pass the standard level of TIS 876-2547 define the value of water absorption for 2 and 24 h. show Fig 4.3.

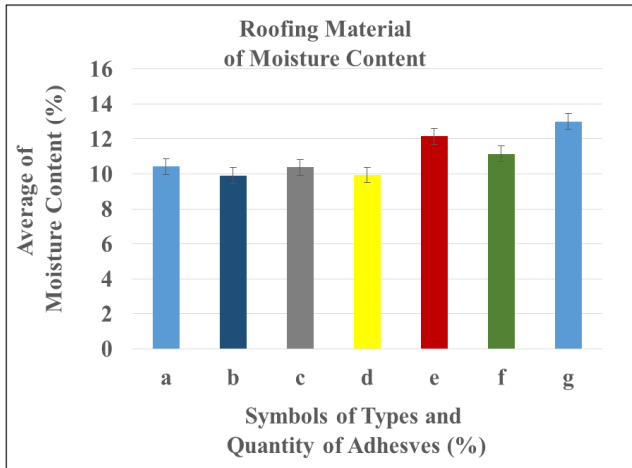

Fig 4.2 Average of moisture content

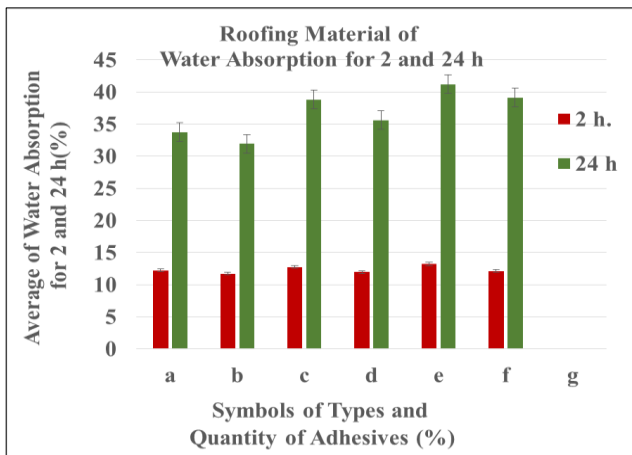

Fig 4.3 Average of water absorption for 2 and 24 h.

At water leakage tested at 2 hours of roofing sheet using PMDI, UF and PF resin as the adhesive were 5% and 10% for the sheet with the density of 700 kg m<sup>-3</sup>. For the water leakage tested at 2 hours. the results of leak proof test of roof sheet material from roofing sheet material from oil palm empty fruit bunching fibers did not appear to leak under the water the washed side of the sheet.

Regarding thickness swelling for 2 and 24 h, the oil palm empty fruit bunching fibers sheet with synthetic adhesive at 5% and 10% of phenol- formaldehyde resin contains average of thickness swelling for 2 h at 8.15 and 5.24%, and at 11.34, 9.32 % for 24 hours. Similarly, the oil palm empty fruit bunching fibers with synthetic adhesive isocyanate resin contains average for 2 h at 3.15 and 2.81%, and at 9.24 and 5.82 % for 24 hours respectively. By comparison, the sheet made from oil palm empty fruit

bunching fibers with synthetic adhesive urea-formaldehyde resin has average of thickness swelling for 2 h at 6.25 and 3.12%, and at 10.33 and 8.43% for 24 hours respectively. The value is considered to pass the standard level of TIS 876-2547. That is the thickness swelling value of a flat pressing sheet for 2–24 h must not exceed/or equal 12%.

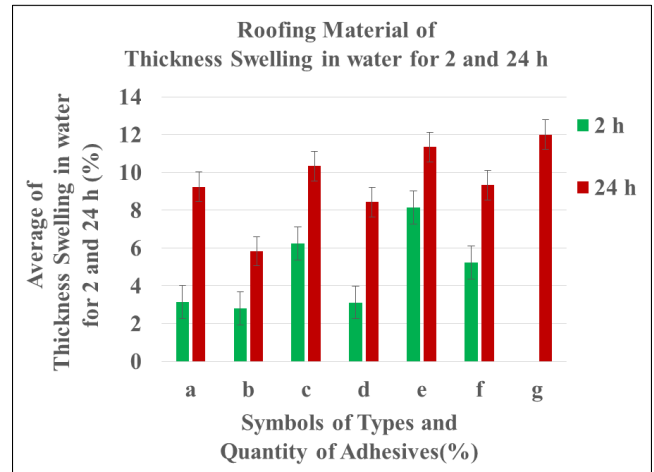

Fig 4.4 Average of thickness swelling in water for 2 and 24 h

#### 4.2 Results of Mechanical Properties

The researchers test the sheet to find mechanical properties. Such properties compose of bending force resistance, modulus of rupture and elasticity, as well as impact strength which are tested by Universal Testing Machine. In addition, the tests cover. The tests depend on the standard test of TIS 876-2547, JIS A 5908-2003 (8 types) and ASTM D 256-2006.

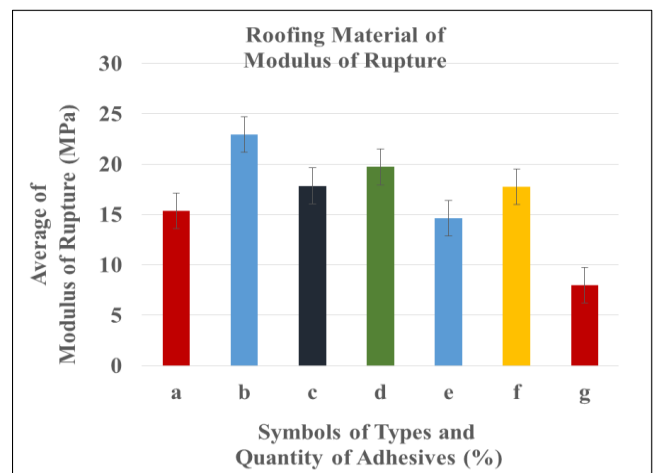

Fig 4.5 Average of modulus of rupture

Regarding bending force resistance and modulus of elasticity, the sheet made from oil palm empty fruit bunching fibers with synthetic adhesive at 5% and 10% of phenol -formaldehyde resin consists of average at 14.64 MPa and 17.74 MPa. Whereas the sheet with synthetic adhesive isocyanate resin consists of average at 15.35 MPa

and 22.95 MPa respectively. However, the sheet made oil palm empty fruit bunching fibers and synthetic adhesive urea-formaldehyde resin consists of average at 17.84 MPa and 19.72 MPa. shows the average of modulus of elasticity at 31.51MPa and 2128 MPa.

At the same time, the oil palm empty fruit bunching fibers sheet with synthetic adhesive at 5% and 10% of phenol-formaldehyde resin consists of average at 2183 MPa and 2214 MPa.

Similarly, the roofing sheet material from oil palm empty fruit bunching fibers sheet with synthetic adhesive isocyanate resin shows the average at 2186 MPa and 2221MPa and urea-formaldehyde resin consists of average at 2184 MPa and 2218 MPa. respectively. So, it can be said that the sheet from oil palm empty fruit bunching fibers can pass the standard level of TIS 876-2547.

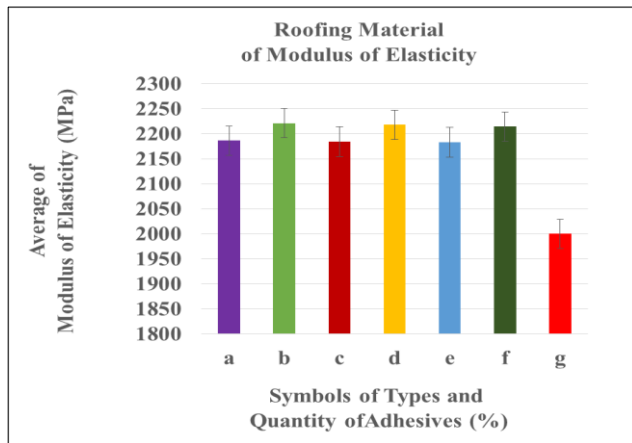

Fig 4.6 Average of modulus of elasticity

The standard clarified that a flat compressing sheet must contain bending force resistance required that is more than 8 MPa. In addition, the modulus of elasticity must be more than/or equal 2000 MPa. Unfortunately, the oil palm empty fruit bunching fibers sheets with synthetic adhesive phenol-formaldehyde resin and synthetic adhesive isocyanate resin and urea-formaldehyde resin can pass the standard level of bending force resistance and modulus of elasticity.

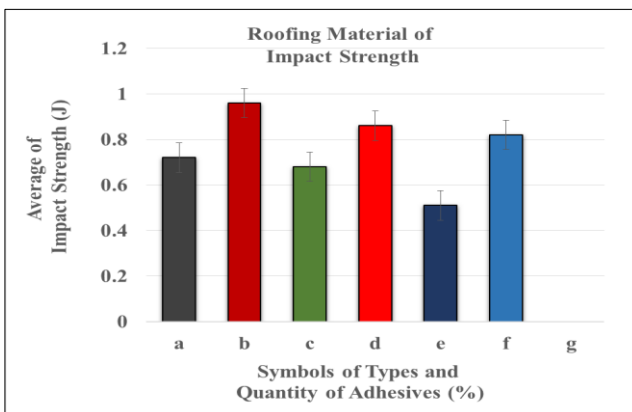

Fig 4.7 Average of impact strength

Considering the value of impact strength the result shows that the sheets of oil palm empty fruit bunching fibers with synthetic adhesive at 5% and 10% of phenol-formaldehyde resin consists of average at 0.51 J and 0.82 J. Similarly, the roofing sheet material from oil palm empty fruit bunching fibers sheet with synthetic adhesive isocyanate resin contains the average of impact strength at 0.72 J and 0.92 J. whereas the one with synthetic adhesive Urea formaldehyde resin contains 0.68 J and 0.86 J. respectively.

4.3 Results of Thermal Properties

Result of Testing Thermal Property, the researchers operate thermal analysis by Thermogravimetric Analysis (TGA) Instrument. It is the process to measure thermal conductivity and thermal resistance. The researchers test the cutting part of corrugated roofing sheet of size 300x300 mm, referring to the standard of ASTM C 177-2010.

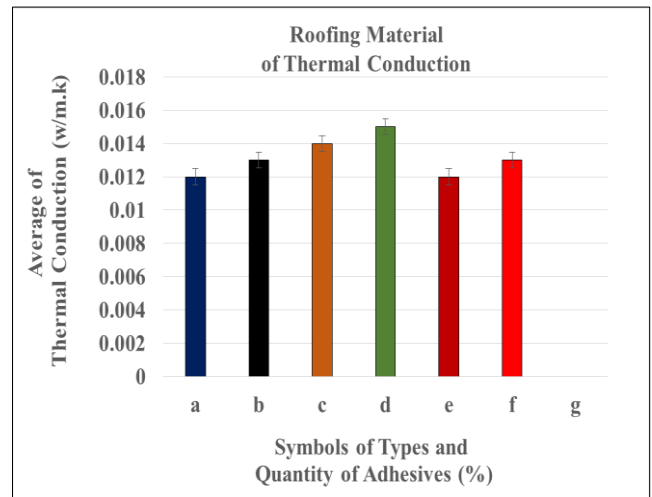

Fig 4.8 Average of thermal conduction

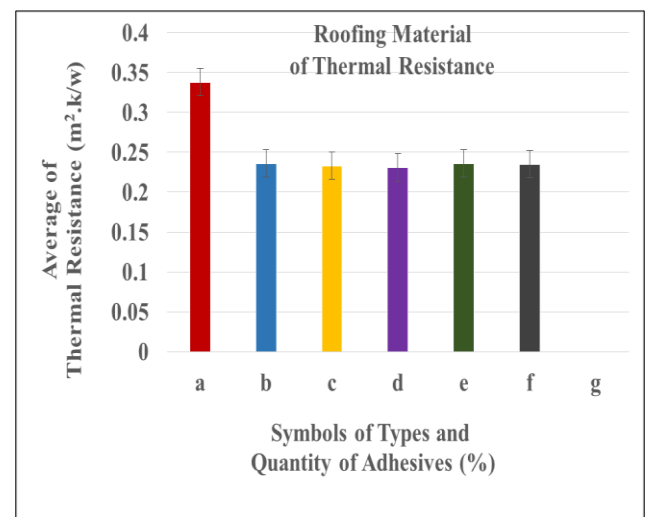

Fig 4.9 Average of thermal resistance

As a result, the average of thermal conduction and thermal resistance for the sheets of oil palm empty fruit bunching fibers mixed with synthetic adhesive at 5% and 10% of isocyanate resin indicates at 0.012 W.m k-1, 0.338 m<sup>2</sup>.k W-1, and 0.013 W.m k-1, 0.236 m<sup>2</sup>.k W-1. And the oil palm empty fruit bunching fibers sheets with synthetic adhesive Urea formaldehyde resin consists the average at 0.014 W. m k-1, 0.233 m<sup>2</sup> k W-1 and at 0.015 W.m k-1, 0.231 m<sup>2</sup>.k W-1 respectively. By comparison, the oil palm empty fruit bunching fibers sheets with synthetic adhesive Phenol-formaldehyde resin shows the average at 0.012 W m k-1 and 0.236 m<sup>2</sup> k W-1 and 0.013 W m k-1 and 0.235 m<sup>2</sup> k W-1 respectively.

The study of producing roofing sheet material from oil palm empty fruit bunching fibers aims at studying the quantity of adhesives. That is synthetic adhesive Phenol-formaldehyde and urea-formaldehyde at 5%,10% and synthetic adhesive isocyanate resin .The study deals with testing physical, mechanical, and thermal properties, according to TIS 876-2547 and JIS A 5980-2003 and ASTM C 177-2010 and ASTM D 256-2006a. Also, According to the test, it is found that the roofing sheet from oil palm empty fruit bunching fibers with synthetic adhesive isocyanate resin 5% and 10% contains higher properties than the one with synthetic adhesive Phenol-formaldehyde 5%and 10%. That is synthetic adhesive isocyanate resin provides higher mechanical properties. The sheet is durable for serious situations. It is dense and hard. The surface is strong enough to anchor impact strength and modulus of rupture. Regarding thermal properties, it is found that thermal conductivity is at nearly level as insulation of commercial production 0.1212-0.1585. (Value of thermal resistance of other types of commercial production materials 0.023-0.280 W/m.k-1

## V. CONCLUSIONS

The following conclusions are made based on the laboratory experiments carried out in this investigation.

In this study, the physical, mechanical and Thermal properties of corrugated roofing sheet material produced from oil palm empty fruit bunch fibers were investigated. The roofing sheet material from oil palm empty fruit bunching fibers has smooth external surface. The material in fibers and inside the sheet touch each other closely. The board passes the standard level of TIS 876-2547 dealing with Flat pressed particleboards. It is obvious that natural fiber has specific property. Which means, it is helpful for heat insulation, light, resistant to bending force. It is a way to increase alternative material which is inexpensive and has good quality for building material. Hence, it is another alternative material that will reduce capital cost. People can select agricultural waste material which are easy to find in locality. Appropriate material and production technology can be operated. Besides, the most important thing, the product will make people more understand and realize the value of using natural resources. The achieved roofing sheet material were suitable for material asbestos roofing tiles

making. The product is also regarded as another choice to add value for farmers.

## REFERENCES

- [1] Kuhad, R.C.,1993, "Lignocellulose Biotechnology : Current and future prospects", Critical Reviews in Biotechnology, Vol.13, No.2, pp.151-172.
- [2] S. Tengkaew, D. Wiwattanadate, Study of Source and Potential of Biomass from Field Corn in Thailand, Princess of Naradhiwas University Journal.6 (3) (2014) 102-111.
- [3] P. Wangwan, W. Tamthong, S. Kraisuwan, Fibrous webs from corn husks, Proceedings of The 55th Kasetsart University Annual Conference, Kasetsart university, Bangkok, Faculty of Agriculture, Department of Home Economics, (2018) 969 - 976.
- [4] A. Pasilo and U.Teeboonma, Investigation of the properties of roofing tiles manufactured from agricultural residues. International Conference on sustainable Energy, Environment and Information Engineering, (SEEIE 2016) (2016) 509-514.
- [5] Jessada W O, Prayoon S, Chaiyaprek A, Kritte E, Sunate M, Kaichai A, Supaphorn T, Mechanical and Physical Properties of Roof Tile Prepared From Sugar Cane Fiber". International Journal of Advanced Culture Technology Vol.3 No.1 (2015) 86-89.
- [6] Jacob Olaitan Akindapo, Umar Alhaji Binni, Olawale Monsur Sanusi, Development of Roofing Sheet Material Using Groundnut Shell Particles and Epoxy Resin as Composite Material. American Journal of Engineering Research (AJER)e-ISSN:2320-0847 p-ISSN:2320- 0936 Vol.4 Issue.6 (2015) 165-173.
- [7] Darsana P. Ruby Abraham, Anu Joseph, Arakkal Jasheela, Binuraj P.R, Jithin Sarma, Development of Coir-Fiber Cement Composite Roofing Tiles. International Conference on Emerging Trends in Engineering, Science and Technology (ICETEST-2015) Procedia Technology 24 (2016) 169–178.
- [8] Santhosh B.S, Raghavendra N.R, Deepesh Jain, Vishal Singh, Ayush Pareek , Strength of corrugated roofing elements reinforced with coir. International research journal of engineering and technology (IRJET). Volume 04 Issue 06 (2017) 2371-2374.
- [9] Thailand Industrial Standards Institute, "Flat pressed particleboards", TIS. 876-2547, Ministry of Industry, (2004) 1-17.
- [10] Thailand Industrial Standards Institute, "Concrete Roof Tiles", TIS. 535-2556, Ministry of Industry, (2012) 1-17.
- [11] Japanese Standards Association Particleboard 2003, JIS A 5908-2003 Japanese Industrial Standard Tokyo, Hohbunsha Co.Ltd. 23 p.
- [12] American Society for Testing and Materials, 2006, "ASTM D 256 -06a Standard Test Methods for Determining the Izod Pendulum Impact Resistance of Plastics", In 1990 Annual Book of ASTM



Standards, Vol. 08.01, Philadelphia, ASTM. pp. 57 - 73.

- [13] American Society for Testing and Materials. 2010, ASTM C 177-10 “Standard Test Method for Steady-State Heat Flux Measurements and Thermal Transmission Properties by Means of the Guarded-Host- Plate Apparatus”. In Annual Book of ASTM Standards MD, U.S.A., Vol. 04.06. pp. 21 - 32.

# Future of Education Post Covid-19 Pandemic: Reviewing Changes in Learning Environments and Latest Trends

<sup>[1]</sup> Abdullah M. Al-Ansi, <sup>[2]</sup> Ahmed Al-Ansi

<sup>[1]</sup> Faculty of Economic and Business, University of Muhammadiyah Yogyakarta, Grand Citra Regency, Kasihan, Bantul, Yogyakarta, Indonesia

<sup>[2]</sup> Faculty of Infocommunication Networks and Systems, The Bonch-Bruевич Saint-Petersburg State University of Telecommunication, Petersburg, Russia

E-mail: <sup>[1]</sup> ebrar.ansi@yahoo.com, <sup>[2]</sup> ahmedalansi16@gmail.com

**Abstract**— This paper investigates the accelerated transitions in education from traditional learning environment (TLE) through online learning environment (OLE) to Social, Innovative learning environment (SILE) and the latest trends of this change. Stages of transition were divided into three parts: before, during and after covid-19 pandemic which was the reason of this accelerated change. Features and characteristics of every stage of transitions were analyzed and discussed based on Ed-Space and classrooms, learning/teaching process, curriculums, ICT applications, Ed-approaches and knowledge transformation. A mixed-method design of comparative and thematic analysis approaches were used to investigate learning environments based on the literature reviews of previous publications in different learning environments. The analysis of these features revealed the main characteristics and differences in every stage. New trends of OLEs and SILEs including cloud platforms, MOOCs, Digital LMS, OER-OEP, m-learning and social network applications have been identified. Finally, this research has recommended some approaches for students/teachers to adopt OLEs and SILEs applications and educational institutions, governments and international community to support OLEs and SILEs in the future.

**Keywords**— Traditional, Online, Social learning Environment, Tech-Edu-Trends, Covid-19

## I. INTRODUCTION

At the beginning of 2020, Covid-19 pandemic has caused serious problems in education started by ending of traditional learning and closure of most of schools around the world and continued to cancelation of examinations, academic seminars and workshops in addition to distance learning disruptions. This impact has raised many questions about challenges, opportunities and solutions of such problem. In addition, sudden transition of traditional learning to online learning opened another doors of discussions for scholars, researchers and decision-makers about the future of education. Traditional learning space; bricks and mortar (Weller, 2007) have been changed to online learning space; ICT and internet access (Al-Ansi, Suprayogo, & Abidin, 2019). Learning environment has been transformed totally to interactive social learning environment. Future of education depends on the ability of educational institutions to adopt ICT and adaptation with new implications after pandemic.

Dramatic changes in learning environment during Covid-19 have affected students, teachers, families and policies makers in education. In the other side, rapid technology development helped transition to distance learning by the high volume of information and approaches of receiving such information (Finger & McGlasson, 2007). Other studies have discussed the different learning environments including traditional, online, blended and distance learning. During 1996 and 2008, a report by Edu-Department in

United States identified 51 independent factors among traditional and online learning instruction. This report states students who participated in online or blended classes were more effective than those who have face-to-face traditional learning. Another study by Means, Toyama, Murphy, and Baki (2013, p. 35) stated that “Distance learning was more effective than traditional learning or face-to-face learning and learning in blended environments is more effective than learning in person”. Furthermore, Shachar and Neumann (2010) stated that students who stake online courses showed better performance than students who take traditional courses. Recently, study by Wu (2015) about comparison among online and face-to-face learning stated that students in online environments perform same as or better than students in traditional environments.

Besides, predicting education future is still fraught with many challenges due the quick transition to complete online learning. Some of these challenges were concluded in many previous studies. Failure of conducting online learning due to some difficulties related to using technologies and e-learning systems (Almaiah & Al Mulhem, 2019), lack of technical support to facilitate various activities (Eltahir, 2019), lack of awareness of interest and no-responsibility of students to do more efforts and inconsistent e-learning readiness (Al-Araibi, Naz’ri Bin Mahrin, & Yusoff, 2019), lack of security and privacy (Almaiah & Alyoussef, 2019) and other problems related to lack of ICT infrastructure (Almaiah & Al Mulhem, 2019). However, many of opportunities have been created to implement new methods

and practices in online and social learning environment. Some of these opportunities include new trends in learning such as cloud platforms, MOOCs, m-learning, digital LMS, OER, OEP and social networking applications.

**II. OBJECTIVES**

The main objectives of this study include:

- Reviewing features and characteristics of learning environments (traditional, online and social innovative learning environments) in order to understand the changes regarding transition before, during and after Covid-19 pandemic.
- Exploring the new trends in education post Covid-19 pandemic in order to gain best practices to cope with this problem and improve learning/teaching process.

**III. METHODOLOGY**

A mixed-method of comparative and thematic approaches were suitable for conducting this study. Comparison between three learning environments depends on ten factors in every learning environment. These factors are educational space, classrooms, learning process, teaching process, curriculums, using technology, educational

approaches, and knowledge transformation in addition to student and teacher role. Comparative approach depends on the literature review of previous studies for three different learning environments. Thematic approach was used to investigate the latest trends in education. A thematic approach is helpful to explore and identify relevant researches in addition to collecting and analyzing data of previous studies (Liberati & et. al, 2009). The literature of this paper was introduced in three stages before pandemic (Traditional learning), during pandemic (Online learning) and after pandemic (Social innovative learning).

**Procedures of thematic approach:** research procedure as shown in fig. 1 presented the different stages of methodology. Stage one include the literature review of every learning stage (traditional. Online and social innovative environments). Stage two introduce using thematic approach to identify and classify the different factors of every learning environment and its characteristics. Stage three is about Gathering the main characteristics and features of learning environments as presented in table 1. Braun and Clarke (Braun & Clarke, 2006) introduced five steps to conduct thematic analysis namely: data familiarizing data, codes generation, seeking themes, definition of themes, and finally writing the report.

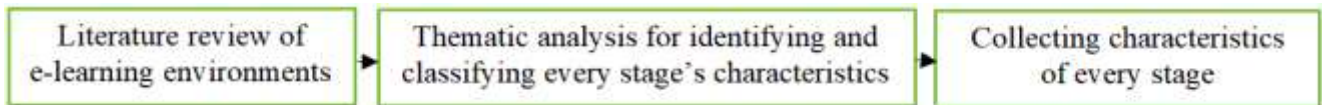

**Figure 1: Framework of Methodology**

**IV. STAGES OF TRANSITIONS IN LEARNING ENVIRONMENTS**

At the beginning of the new millennium, many of educational institutions have adopted technology in learning process. Using of digital devices in classroom, internet access, ICT-based learning, blended learning and finally distance learning. This part investigates the transitions from traditional learning environment (TLEs) before Covid-19 through online learning environment (OLEs) during the pandemic to innovative learning environment (SILEs) after the pandemic.

**V. TRADITIONAL LEARNING ENVIRONMENTS (TLEs)**

This first stage is Traditional Learning Environment (TLEs) before the Covid-19 pandemic. Characteristics of this stage includes physical classrooms where students/teachers have to attend classes at campus/school, teacher-based learning where teacher is the transmitter of knowledge, many of educational materials and books are printed, transition of knowledge approach and many of ICT tools are part of classrooms.

**Educational Space and Classrooms**

Traditionally, this kind of learning is based on face-to-face approach in physical environment with less affordance (Weller, 2007) which is also known as (brick and mortar

classes). Students who learned in these places have adopted the concept of a "broadcast model" of learning (Long, 2005). Traditional learning creates what is called as sensory memories, which are also called, "ability of emotional responses" that work to influence their cognitive and behavior (Graetz, 2006). Some of researchers think that, the concept of traditional classes limits the student/teacher activities and interactions (Mulcahy, 2015) where classrooms are seen as "containers" and hampers the ability of teachers to easily activate many different approaches as student-centered and ICT-based learning (Dovey, 2014). Traditional or conventional classrooms are ideal for teacher-based learning methods that prefer linear and standardized instruction (Dumont, 2010). Physical learning environments design and features also impact on the students' experience and orientation towards learning (Wilson, 2016). Some of these factors are: learning space, lecture hall, teaching rooms, access to library, toilets, open social areas, room layout, colors and furniture and up to date technology. Obviously, understanding the students' need is critical to develop suitable learning space (Kollar, 2014) where the space should support the strategies learning and Provide suitable environments for students to manage space for their own work productivity (Shouder, 2014).

**Learning /Teaching Process**

In traditional learning environments, teacher is the transmitter of knowledge, controller of class and responsible for all activities and students most of time are receivers of instructions. Traditional learning focuses on rote learning and memorization in addition to examination as the end of educational process. Teacher-centered refers to communicating and facilitating learning approaches and materials for students where teachers have a secondary role (Mascolo, 2009). Another approaches where they depend totally on the teacher led to exam-centered approach to save time and needs of the test's content (Grant, 2006). Papers and pencils exams, scripted curriculum and face-to-face teaching in traditional learning approach made students increasingly bored and unmotivated and teacher more stressed about teaching techniques (Fullan, 2013). Some of researchers prefer teacher-centered learning when the teachers are knowledgeable in content and applying motivational techniques to their approach of teaching (Espenshade, 2009). Moreover, teachers spend more their time in explaining content and discussing related issues with students by using black/whiteboards and projectors while students taking notes and asking questions (Peyton, 2010).

**Curriculum**

Traditional learning environments depends on teacher-centered learning, textbook instruction, blackboards and pen and paper approach. In this stage, despite many of non-traditional educational methods have been implemented such as Team-based Learning (TBL), Problem-based Learning (PBL), Content-based Learning (CBL), flipped classrooms and Self-direction Learning (SDL), but the curricula plays the main role and textbooks are the basic of the learning process (Choi, Lindquist, & Song, 2014; Nishigawa & et al, 2017). In addition to textbooks as main characteristic of curricula in this learning environments, visualizations and 3D pictures, presentations and videos play a significant role in traditional learning.

**Educational Approaches and Knowledge Transformation**

Traditional learning depends on transitional approach where information and knowledge are being transmitted from educators to learners. Teacher's belief and role determine the type of educational approach and knowledge delivered to students (Domović, Vlasta, & Bouillet., 2016; Rapoport, Rubinsten, & Katzir., 2016). Different studies approved the importance of teacher role in nature of teaching and learning in traditional environment. Although many of educational institutions are using the traditional learning approaches for delivering knowledge and practices, but during the last two decades, many of ICTs and technologies tools have been brought to classrooms. Interaction among students and technology have facilitated their future careers and improved their skills and competences. The new future jobs depends on the ability of graduates in interaction with ICT and more general skills,

such as the creation and sharing of collaborative knowledge and metacognitive skills (Kozma, 2005). Transitional learning outcomes are cognitive, projective, application, synthesis, group strengthening, and self-direction (James, 2013).

**VI. ONLINE LEARNING ENVIRONMENTS (OLEs)**

This stage introduces the approaches and techniques in Online Learning Environments (OLEs) during the Covid-19 pandemic. Main features of this stage includes learning from home, online classes, student-based learning, interaction environment between students and teacher, e-learning books and materials and creating knowledge approaches.

**Educational Space and Classrooms**

In online learning, students, educators and administrative staff need not go anymore to school again. Physical learning environment is the home or any place they want to. LMS is controlled by educational institutions and educators while students have little space to do their activities (Väljataga & Tammets, 2011). Socialization and interaction changed from campus to interactive platforms and social media. Many of students prefer use social media where they are able to interact more with their classmates and teachers. Different previous studies have proved that students/teachers have spent significant time on social media interacting and participating in different activities (Junco, 2012). In addition to social network and online applications, educational space at home facilitated family gathering and community around. One more benefit about online learning environment is that students/teacher choose the suitable space for them to learn/teach at or outside the home.

**Learning /Teaching Process**

During Covid-19, online learning have become the only approach to continue learning. Many of educational institutions had experienced online learning/teaching as extra activities or limited use for those who were unable to attend real classes. Those experiences enabled them to improve their skills and transform totally to online learning/teaching. Although, many of students/educators are struggling to learn many different skills to adopt this approach but since total closure of schools/universities, online learning became compulsory. Learning based on student is the main feature of online learning process where includes both (PBL) and (PjBL). These two approaches are similar (Hung, 2011) but each has unique features. PBL introduces the problem for students to solve whereas PjBL introduce the artifact in mind and students in PBL produce conclusions of problem-solving while in PjBL ends with a product. In both approaches, teacher/educator is the facilitator of learning process but not transmitter of knowledge. Online learning/teaching process also includes many different approaches like Learning Management Systems, virtual classrooms, MOOCs and many entertainment applications. These tools and approaches



enable virtual interaction more flexible than physical interaction such as student to student, student to teacher, student to content and teacher to teacher, teacher to content and content-content (Zornić & Hasanović, 2011).

### Curriculum

In online learning environment, the use of textbooks is very rare where students prefer use e-books, presentations and audio and video content. E-learning materials remain the same in traditional learning with little different where all of these materials became e-learning materials. Although, many of interactive and social platforms have been adopted as part of e-learning process, but this progress is limited due to modernity of full e-learning, lack of infrastructure and unqualified student/teacher competences. Regardless of such challenges, Curricula are not separated into individual subjects, this allows students to develop skills across the curriculum, learn and apply their knowledge wherever they need it (Papert, 2001).

### Educational Approaches and Knowledge Transformation

OLEs interactive learning is the approach of learning where students and teachers use online applications and platform to communicate and interact with each other. Knowledge is also created by this interaction and participations of students and teachers in opposite traditional learning where teachers are the transmitters of knowledge. Sharing and creating of e-learning materials, videos, presentations and e-books enhance the learning, share the experiences and reflect the teaching performance (Yung, Wong, Cheng, & Hui, 2007; So, Hung, & Yip, 2008; Lee & Wu, 2006). Technology is the base in the online learning and the tool of creating knowledge as well. Teaching is conducted by constructivism, Web 2.0 tools and interactive platforms. Teachers are responsible of planning classes, determining the approaches and applications of learning and facilitating integrated sequence with technology while students are responsible for building and demonstrating knowledge as well as collaborating with their peers to create knowledge.

## VII. SOCIAL INNOVATIVE LEARNING ENVIRONMENTS (SILEs)

In Social Innovative learning environments, there are many predictable specifications of social innovative learning environments stated after facing Covid-19 pandemic such as tech-rich spaces, interactive platforms, Learning based on ICT-BL, Community learning environment (CLE), students/teacher are learning/teaching everywhere internet available, social media interaction and innovative applications of knowledge. In this stage, there is a specific selection on the use of ICT and teaching is conduct through innovative and open social environments.

### Educational Space and Classrooms

SILEs are multi-Social media, technology-integrated and attractive learning environments that include different practices in education (OECD, 2015). Different studies

have proven the evidence of effective ISLEs as better learning methods better than traditional classrooms (Dovey, 2014). In SILEs, there is no physical classrooms or just learning online at home, but the space of learning is anywhere has internet access and mobile phone such as coffee shops, clubs and open space outdoors. Moreover, social media has enriched learning process where students/teachers are able to interact and communicate anytime anywhere easily. In SILEs, learning space is not restricted by physical boundaries and classrooms transformed to social networks and groups in social media applications. Facilitating learning spaces depend on features of social media applications and how they are comfortable, affordable, reachable and easy to use. Learning virtual space in SILEs is represented as electronic emulations of the multidimensional natural world.

### Learning /Teaching Process

Opposite of traditional learning and online learning, where traditional learning adopt teacher-centered and online learning represents student-centered approach, learning in innovative social environments is ICT-based method. Teaching process in SILEs also depends on interaction of community with technology at first place which means not only teacher-student interaction but family, technology, space and community have part in this learning environment. Teaching and learning in SILEs requires different approaches, collaboration, communication and includes different knowledge and emotions (Greenhow, Burton, & Robelia, 2011; Ranieri, Manca, & Fini., 2012; Pimmer, Linxen, & Grohbiel, 2012; Gao, Luo, & Zhang, 2012). Process of learning in SILEs is being characterized as Self-direction, Self-initiation, Peer- or other influenced, Unintended network effects, Network support, Community evaluation (rating, commentary, Expertise via participation, bookmarking) and other modal such as videos, pictures, rating and tags. (Greenhow & Lewin, 2016). Social media and innovative learning approaches have enhanced the culture of new learning environment. Learners and educators can engage and participate in digital culture potentially benefitting of collaborative learning and developing new skills (Brenner & Smith., 2013; Ofcom, 2014). Despite, learning through social media also enrich skills and experience of learners and educators, many of challenges also need to be met to understand the complexity of future learning.

### Curriculum

In addition to learning e-materials, whiteboards, interactive platforms and virtual excursions and practices are the most features of curriculum in social interactive learning environments. Learners and educators have the ability to read, edit, organize, interact and save these learning materials anytime. Open textbook, MOOCs, OER Repository and open collaboration forums are available for educators and students to learn, share and download according to their needs (UNESCO, 2015; Algers, 2019). Although many of open educational materials are available

online, but there are also some limitations and difficulties related to choosing best materials suitable to the need of learners. Some of these challenges are copyright, license, unfamiliarity and quality of such materials (Yang, 2020; Ozdemir, 2017).

### **Educational Approaches and Knowledge Transformation**

In social interactive learning environments, students learn through social networks and applications. In another words, knowledge is not only transformed or created among students and teachers, but knowledge is gained through interactive applications. Students are more motivated to engage in leaning through open interactive environments (Nascimbeni & Burgos, 2016). Learning through social networks enables students to create new open educational resources and practices (OER-OEP) in any specific topic based in different resources and references.

## **VIII. NEW TRENDS IN FUTURE OF EDUCATION**

During the COVID-19 pandemic, many of new trends have been resulted in learning/teaching process. Traditional learning have transformed to distance learning where many of policies, strategies, techniques, applications and suggestions reshaped and restructured the new culture of learning. This part of paper investigate these trends. It is significant to understand that many of these trends in learning have been identified through last few years and adopted as part of traditional learning strategies. During and after Covid-19 pandemic, these forms and techniques have been developed to be essential in distance learning infrastructure.

### **Cloud Platforms**

The idea of cloud platform or interactive platform is to facilitate the use of ICT to create better learning environment. Cloud Platforms depends on ICT applications, LMS, interactive websites and social media. Cloud platforms enables components of traditional learning such as textbooks, note writing, discussion in groups, ideas sharing and accumulated cognitive in sufficient way based on ICT, LMS and e-learning components in addition to more chat box, news feeds ability to comment during open course system (Septiani, 2017). PCs, laptops, tablets and cellphones, employ built-in integrated cameras, GPS sensors, and internet access to embed real-world environments with dynamic and context-aware interactive digital content (Chiang, Yang, & Hwang, 2014) are the tools of cloud platforms where learners/educators can interact with each other. In addition, teleconferencing applications have raised during the pandemic such as Zoom, Google Meet, Facebook Groups, Microsoft Teams and many other applications that facilitated communication between learners and educators and gave them the ability to interact with each other synchronously.

### **Digital LMS**

Digital LMS helps learners and educators to access anytime anywhere. After closure of schools/universities due to the Covid-19 crisis, LMS was the lifeline for education to survive again. LMS is also online-platforms that include learning systems (LS), content and course management systems, portals, evaluation systems and instructional management system. Since students of this time are the digital natives (Prensky, 2002) or social media generation, using LMS is easier and more functional for many of them. LMS revolutionized the approaches of learning during the last few years and will be continuing where expectation of LMS growth from USD 13.14 billion in 2020 to USD 25.7 by 2025 (Markets, 2020). LMS has enabled student-teacher interaction and gave them the ability to connect, communicate, share information and ideas, share educational materials, conducting examinations, managing courses, tracking students' attendance and assessment. Recently, there are many of opened source cloud-based LMS that introduce low-cost courses, free solutions and maintenance. But, the large LMS are those installed and developed by educational institutions where university/school own them and keep maintenance and security. The most characteristics of LMSs include customer support and experience, software feature and innovation, economic growth, friendly use and feedback. Some of famous LMS include Moodle, Loop, Docebo, LearnUpon, Adobe Captivate Prime, Talent and Sap Litmos (Pappas, 2018).

### **M-Learning**

M-learning refers to browsing knowledge and learning through phones and/or mobile-phones applications. Mobile-learning is categorized under e-learning and involved in mobile computing (Behera, 2013). Regardless many of limitations in using m-learning approach, mobile phone became an important tool for learning during the pandemic and will continue to be post covid-19 crisis. Ease of use, mobility, affordability and ability to browse information quickly are the most characteristics of m-learning. In addition, mobile devices are being used as a communication tool through social media, using mobile products such as scanner, printer, video and camera to conduct teleconferencing and join cloud learning platforms. M-learning expands learning/teaching beyond the traditional learning in classrooms, increases the flexibility and opens many of opportunities for leaners/educators through online learning environments (Kumar Basak, 2018). M-leaning also has a fundamental perspective of e-learning including technology mobility, learning and learner synchronously (El-Hussein & Cronje, 2010). Finally, many studies discussed the different features and use of m-leaning including: basic parameters of m-learning such as portability, social interaction, sensitivity to the contextual, connectivity, and ability of customization (Kothamasu, 2010), incorporating m-learning in higher education environments by awareness and knowledge of students (Sobri & Fatimah, 2012), high satisfaction of students while using m-learning and m-learning is a future

learning unique tool (Mao, 2014), integrating m-learning by various software and hardware technologies to facilitate communication and interaction with multimedia applications like short messaging, gaming, examinations and multimedia contents (Mohanna, 2015).

### MOOCs

Massive Open Online Course (MOOCs) includes formal and informal educational online resource based on connective knowledge (Siemens, 2018) and behavioral approach (content-based) theories (Yuan & Powell, 2013). The idea of c-MOOCs is introducing the connection between different parties to engage at discussions and collaboration while x-MOOCs is designed as traditional learning courses but online (Yousef, 2015). There are many examples of e-learning MOOCs including Khan Academy, edX, Peer-to-Peer University (P2PU), Udacity, Udemy, Alison and Coursera. Educators and professionals have the main part in preparing and producing many of MOOCs materials and downloading them online for learners where they also spend much time for this process. During last few years, millions of students/learners had joined MOOCs. For instance, coursera includes thousands of courses online, different professional certificates, many online degrees in bachelor and master, and more than 60 million learners (Coursera, 2020). In the other hand, many of critiques have discussed some challenges related to MOOCs such as attrition rates and course drop out (Hew, 2016). Many of reason behind dropping out of completing courses such as difficulty of use, workload, no motivation, inequality and fake registration (Alraimi, Zo, & Ciganek, 2015).

### OER-OEP

Open Educational Resources and Open Educational Practices are new approaches of learning. OER and OEP are set of learning and teaching materials that enable pedagogy and define its characteristics. Many of these materials are available online for public use with no-cost access. Users are able to reuse, repurpose, adopt and redistribute these materials anytime based on their needs (Stracke, 2019). OER is content-based while OEP is practice-based learning approach. Characteristics of OER include ability of reuse, revision, remixing, redistribution and retaining these educational resources (UNESCO, 2015). OEP has the potential to improve the opportunity for learners to access quality educational content, thus helping to achieve both accessible and lifelong learning (Nascimbeni & & Burgos, 2019). Implementing OEP requires reusing of OER in different ways to support students' learning and keep them active and innovative which result a better educational outcomes. In addition, applying OEP requires many steps such as openly licensed, open learning and teaching, open collaboration and communication, available assessment and enabling technologies (Huang, 2020).

### Social Networking Applications

Social media networks has significant role in the modern learning and teaching approaches. Through social media applications, students and teachers are able to connect, communicate, interact, share knowledge, send and receive assignments, through the ease and comfort use of cellphones and laptops (Myers, Endres, Ruddy, & Zelikovsky, 2012). Social media applications enhance learning and create professional connections. Most famous social media applications used in online learning are Facebook, Twitter, LinkedIn, Blogs, YouTube, Instagram and Pinterest in addition to communicating applications such as what's app, Telegram, Skype, Line, Imo and Messenger (Chawinga & Zinn, 2016; Dzvapatsva & Mitrovic, 2014). Social media is no longer used as leisure but as platforms for communicating and teaching/learning (Jones, 2015). Social media also gave the opportunity for students to give feedback and educators to identify knowledge gaps and improve the teaching methods (Menkhoff, Chay, Bengtsson, & Woodard, 2014). In addition, social media weather mobile-based or laptop-based has many benefits such as enabling students to interact positively with contextual learning in relation to pedagogical objectives, enabling students to be engaged in collaborative learning and motivating students to post comments and questions (Wheeler, 2010; Menkhoff, Chay, Bengtsson, & Woodard, 2014). Despite the evidence of usefulness of social media applications in learning, there are also many critics and paradoxes hinder the full adoption of these applications (Conole & Alevizou, 2010; Tess, 2013).

## IX. CONCLUSION

This research investigated the different learning environments TLEs, OLEs and SILEs as a resulted changes and dispersions of education post Covid-19 pandemic. Education now depends on distance learning and ICT components. Comparing online and social learning to traditional learning was to understand the huge changes in learning practices and policies. Different characteristics and features distinguished every stage of learning based on many factors such as Educational environment, classrooms, learning and teaching process, curriculums, Technology, educational approaches, ways of acquiring knowledge and students/educator roles. All these features have been changed due to transitions in learning environment. Table below summarizes these changes based on learning environments.



**Table 1: Changes in different learning environments**

Topic	TLEs	OLEs	SILEs
Ed- Environment	Campus/School	Home	Tech-rich Space
Classroom	Physical Classroom	Online classes	Interactive Space
Learning	Teacher-centered	Student-centered	ICT-based/Task-based
Teaching	Educator/Lecturer	Teacher-Student	Community environment
Curriculum	Printed Ed-Materials	e-Ed-Materials	Interactive Platforms
Tech-Space	In classroom	At Home	Everywhere
Ed-Approaches	Transition-Nets	Interactive Nets	Social Networks -SILEs
Knowledge	Transformed	Created	Innovative applications
Student	Passive	Active	Creative
Teacher	Transmitter	Coach	Participant

It is significant to ensure that three different learning environments are very important in future of education. Regardless some changes that have happened during the pandemic, where education completely depends on online and interactive learning, after new normal, education will continue as traditional learning with significant improving in all three environments. In addition, some of new trends that have been adopted and became critical in leaning such as cloud platforms, m-learning, MOOCs, digital LMS, OER, OEP and social networking applications have been analyzed as part of this research.

### Recommendations

According to analysis of transition stages of learning environments before, during and after covid-19 pandemic and new trends appeared after this change, some recommendations for students/teachers, educational institutions, governments and international community should be taking into consideration in order to reduce the risk and mitigate the negative implications of the pandemic.

- Educators and students need to improve their competences and have self-motivation to adopt OLEs and SILEs approaches, techniques and applications in addition to ability to interact through these platforms.
- Educational institutions and governments have to implement new policies and regulations and to assess the transition from TLEs to OLES and support the change to SILEs by providing integrated ICT infrastructure and financial support.
- International collaboration and community interaction became an important necessity to share experiences, support learning environments and provide sustainable development of learning.
- Reshaping, redefining and redesigning of educational systems including learning/teaching process, curriculum, educational space and environment and assessment approaches.
- Adoption of and adaptation with ICTs, cloud platforms, MOOCs, ODR-OEP, m-learning and social network applications.

### Implications

- **Theoretical Implications:** The Covid-19 pandemic is still ongoing, with no certainty over the duration and to what extent the pandemic will continue to affect education systems around the globe. Covid-19 changed the perceptions and understandings of traditional learning process for first time during the history to be completely online learning and will continue to change the methods, approaches, strategies and policies for education for coming years. Some important criteria remain to be measured, such as the way in which social and cultural dimensions affect education patterns in the context of the current crisis. As the situation continues and the crisis is prolonged, education expectations will need to be continuously revised and new theories, policies and collaboration will need to be implemented.
- **Practical Implications:** it is important to know that education after Covid-19 pandemic will not be the same as traditional learning, so educational institutions have to be ready for implementing new strategies, adopt more ICTs equipment and Tech-Ed approaches. Many of students have dropped out of learning during the pandemic and will continue to drop out of schools based on many socioeconomic reasons. In addition, many of students will not be able to pay for schools in case of primary education where families lost their jobs due to pandemic or universities in case of higher education where students themselves are working part time and they lost this work. Financial burden of poor students pushed many families to send their children to work to support the family facing pandemic. In addition, many of students who live in conflict/war areas or displaced, immigrants who were facing many challenges already to remain in schools have been affected more than another groups.
- **Social implications:** during and after the pandemic, people have to care social distancing where they are not allowed to interact directly with each other. This led to physical separation where relationship between students-teachers is now depending on ICT tools and/or social media applications. Most of students got more stress and depression because they have to stay at home to be able to pursue online classes and do their



assignments while in traditional learning they could spend time between school and home.

### Further directions

For further future researches, the big question is that: Will education's future remain the same as in pandemic time (online or blended) or will back again as the traditional education? In addition, role of offline systems, community engagement and international collaboration, entertainment in education, privacy and security challenges will remain important subject for future studies in education.

### REFERENCES

- [1] Al-Ansi, A. M., Suprayogo, I., & Abidin, M. (2019). Impact of Information and Communication Technology (ICT) on Different Settings of Learning Process in Developing Countries. *Science and Technology*, p-ISSN: 2163-2669, e-ISSN: 2163-2677, 9(2): doi:10.5923/j.scit.20190902.01
- [2] Al-Araibi, A. A., Naz'ri Bin Mahrin, M., & Yusoff, R. C. (2019). Technological aspect factors of Elearning readiness in higher education institutions: Delphi technique. *Education and Information Technologies*, 24(1), 567–590. <https://doi.org/10.1007/s10639-018-9780-9>
- [3] Algers, A. (2019). Open textbooks: a balance between empowerment and disruption. *Technology, Knowledge, and Learning* (1):1-16. <https://doi.org/10.1007/s10758-019-09426-5>
- [4] Almaiah, M. A., & Al Mulhem, A. (2019). Analysis of the essential factors affecting of intention to use of mobile learning applications: A comparison between universities adopters and non-adopters. *Education and Information Technologies*, 24(2), 1433–1468. <https://doi.org/10.1007/s10639-018-9840-1>
- [5] Almaiah, M. A., & Alyoussef, I. Y. (2019). Analysis of the effect of course design, course content support, course assessment and instructor characteristics on the actual use of E-learning system. *IEEE Access*, 7, 171907–171922. DOI: [10.1109/ACCESS.2019.2956349](https://doi.org/10.1109/ACCESS.2019.2956349)
- [6] Alraimi, K. M., Zo, H., & Ciganek, A. P. (2015). Understanding the MOOCs continuance: The role of openness and reputation. *Computers & Education*, 80: 28–38. doi:10.1016/j.compedu.2014.08.006.
- [7] Behera, S. (2013). E- and M-Learning: A comparative study. *International Journal on New Trends in Education and Their Implications* 4(3): 65–78.
- [8] Braun, V., & Clarke, V. (2006). Using thematic analysis in psychology. *Qualitative Research in Psychology*, 3(2), 77–101.
- [9] Brenner, J., & Smith., A. (2013). 72% of Online Adults are Social Networking Site Users. Washington, DC: Pew Internet & American Life Project.
- [10] Chawinga, W. D., & Zinn, S. (2016). Use of Web 2.0 by students in the Faculty of Information Science and Communications at Mzuzu University, Malawi. *South African Journal of Information Management*, 18(1). <http://dx.doi.org/10.4102/sajim.v18i1.694>.
- [11] Chiang, T.-H., Yang, S.-J., & Hwang, G.-J. (2014). An Augmented Reality-based Mobile Learning System to Improve Students' Learning Achievements and Motivations in Natural Science Inquiry Activities. *Educ. Technol. Soc.* 17, 352–365. [www.jstor.org/stable/jeductechsoci.17.4.352](http://www.jstor.org/stable/jeductechsoci.17.4.352). Accessed 3 Dec. 2020.
- [12] Choi, E., Lindquist, R., & Song, Y. (2014). Effects of problem-based learning vs. traditional lecture on Korean nursing students' critical thinking, problem-solving, and self-directed learning. *Nurse education today*, 34(1), pp.52-56. <https://doi.org/10.1016/j.nedt.2013.02.012>
- [13] Conole, G., & Alevizou, P. (2010). A literature review of the use of Web 2.0 tools in Higher Education. In A report commissioned by the Higher Education Academy. Milton Keynes: The Open University.
- [14] Coursera. (2020). <https://www.coursera.org/>.
- [15] Domović, V., Vlasta, V. V., & Bouillet., D. (2016). "Student Teachers' Beliefs About the Teacher's Role in Inclusive Education." *European Journal of Special Needs Education* 32 (2): 1–16. <https://doi.org/10.1080/08856257.2016.1194571>
- [16] Dovey, K. &. (2014). Designing for adaptation: The school as socio-spatial assemblage. *The Journal of Architecture*, 19(1), 43–63. <https://doi.org/10.1080/13602365.2014.882376>.
- [17] Dumont, H. &. (2010). Analysing and designing learning environments for the 21st century. *The nature of learning: Using research to inspire practice*, 19-34.
- [18] Dzvapatsva, G. P., & Mitrovic, Z. &. (2014). Use of social media platforms for improving academic performance at Further Education and Training Colleges. *South African Journal of Information Management*, 16(1). <https://doi.org/10.4102/sajim.v16i1.604>
- [19] El-Hussein, M., & Cronje, J. (2010). Defining mobile learning in the higher education landscape. *Journal of Educational Technology & Society*, 13(3), pp.12-21.
- [20] Eltahir, M. E. (2019). E-learning in developing countries: Is it a panacea? A case study of Sudan. *IEEE Access*, 7, 97784–97792.
- [21] Espenshade, T. J. (2009). No longer separate, not yet equal: Race and class in elite college admission and campus life. Princeton: Princeton University Press. p.12-20.
- [22] Finger, G., & McGlasson, M. &. (2007). Information and communication technologies: Towards a mediated learning context. In Y. Inoue

- (Ed.), Technology and diversity in higher education: New challenges (pp. pp. 81–102). Hershey, PA: Information Science Publishing.
- [22] Fullan, M. &. (2013). Towards a new end: New pedagogies for deep learning. Seattle, WA: Collaborative Impact. Retrieved from [http://www.newpedagogies.info/wp-content/uploads/2014/01/New\\_Pedagogies\\_for\\_Deep%20Learning\\_Whitepaper.pdf](http://www.newpedagogies.info/wp-content/uploads/2014/01/New_Pedagogies_for_Deep%20Learning_Whitepaper.pdf).
- [23] Gao, F., Luo, T., & Zhang, K. (2012). “Tweeting for Learning: A Critical Analysis of Research on Microblogging in Education Published in 2008–2011.” *British Journal of Educational Technology* 43 (5): 783–801.
- [24] Graetz, K. A. (2006). *The psychology of learning environments. EDUCAUSE*, 41, 6, 60–75.
- [25] Grant, M. M. (2006). Weighing the risks with the rewards: Implementing student centered pedagogy within high-stakes testing. In R. Lambert & C. McCarthy (Eds.), *Understanding teacher stress in an age of accountability* (pp. 19–42). Greenwich, CT: Information Age Press.
- [26] Greenhow, C., & Lewin, C. (2016). Social media and education: Reconceptualizing the boundaries of formal and informal learning. *Learning, media and technology*, 41(1), pp.6-30.
- [27] Greenhow, C., Burton, L., & Robelia, B. (2011). “Help from my “Friends:” Social Capital in the Social Network Sites of Low-income High School Students.” *Journal of Educational Computing Research* 45 (2): 223–245.
- [28] Hew, K. F. (2016). "Promoting engagement in online courses: What strategies can we learn from three highly rated MOOCs". *British Journal of Educational Technology*. 47 (2): 320–341. doi:10.1111/bjet.12235.
- [29] Huang, R. L. (2020). *Handbook on Facilitating Flexible Learning During Educational Disruption: The Chinese Experience in Maintaining Undisrupted Learning in COVID-19 Outbreak*. Beijing: Smart Learning Institute of Beijing Normal University.
- [30] Hung, W. (2011). Theory to reality: A few issues in implementing problem-based learning. *Education Technology Research Development*, 59(4), 529–552. <http://dx.doi.org/10.1007/s11423-011-9198-1>.
- [31] James, R. (2013). "THE TRANSITIONAL LEARNING MODEL IS AT THE HEART OF OUR TRAINING PHILOSOPHY, DESIGN AND DELIVERY" Copyright © 2013 Health Communication Resources.
- [32] Jones, A. (2015). How Twitter saved my literature class: a case study with discussion. In C. Wankel, M. Marovich, K. Miller, & J. Stanaityte (Eds.), *Teaching Arts and Science with the New Social Media* (pp. 91–105). Bingley: Emerald Group Publishing.
- [33] Junco, R. (2012). The relationship between frequency of Facebook use, participation in Facebook activities, and student engagement. *Computers & Education*, 58(1), 162-171.
- [34] Kollar, I. P. (2014). “Why it is hard to make use of new learning spaces: a script perspective”, *Technology, Pedagogy and Education*, Vol. 23 No. 1, pp. 7-18.
- [35] Kothamasu, k. (2010). *Odl Programmes Through M-learning Technology*. Retrieved from [http://oasis.col.org/bitstream/handle/11599/2214/2010\\_KothamasuK\\_ODLProgrammes.pdf?sequence=1&isAllowed=y](http://oasis.col.org/bitstream/handle/11599/2214/2010_KothamasuK_ODLProgrammes.pdf?sequence=1&isAllowed=y).
- [36] Kozma, R. (2005). National policies that connect ICT-based education reform to economic and social development. *Human Technology*, 5(4), 358-367.
- [37] Kumar Basak, S. W. (2018). E-learning, M-learning and D-learning: Conceptual definition and comparative analysis. *E-Learning and Digital Media*, 15(4), pp.191-216.
- [38] Lee, G. C., & Wu, C. C. (2006). Enhance the teaching experience of pre-service teachers through use of videos in web-based CMC. *Innovations in Education and Teaching*.
- [39] Liberati, A., & et. al, A. D. (2009). The PRISMA statement for reporting systematic reviews and meta-analyses of studies that evaluate health care interventions: explanation and elaboration. *Journal of clinical epidemiology*, 62(10), e1-e34.
- [40] Long, P. D. (2005). *Future of the learning space. Breaking out of the box. EDUCAUSE Review*, July/August 2005, 42–58.
- [41] Mao, C. (2014). Research on undergraduate students’ usage satisfaction of mobile learning. *Creative Education* 5(8): 614–618.
- [42] Markets, L. (2020). *Marketsandmarkets*. Retrieved from [https://www.marketsandmarkets.com/Market-Reports/learning-management-systems-market-1266.html?gclid=EAIaIQobChMItKT-oful3QIVjCqyCh1PcwdkEAAAYASAAEGlGvD\\_BwE](https://www.marketsandmarkets.com/Market-Reports/learning-management-systems-market-1266.html?gclid=EAIaIQobChMItKT-oful3QIVjCqyCh1PcwdkEAAAYASAAEGlGvD_BwE)
- [43] Mascolo, M. (2009). Beyond student-centered and teacher-centered pedagogy: Teaching and learning as guided participation. *Pedagogy and the Human Sciences*, 1(1), 3-27.
- [44] Means, B., Toyama, Y., & Murphy, R. F. (2013). The effectiveness of online and blended learning: A meta-analysis of the empirical literature. *Teachers College Record*, 115(3), 1–47.
- [45] Menkhoff, T., Chay, Y. W., Bengtsson, M. L., & Woodard, C. J. (2014). Incorporating microblogging (“tweeting”) in higher education: lessons learnt in a Knowledge Management Course. *Computers in Human Behavior*. <http://www.sciencedirect.com/science/article/pii/S074756321400681>. Accessed 4 Dec 2015.
- [46] Mohanna, M. (2015). *Using knowledge engineering for modeling mobile learning systems*. Doctoral Dissertation, Universite Laval, Canada.

- [47] Mulcahy, D. C. (2015). *Learning spaces and pedagogic change: envisioned, enacted and experienced*. *Pedagogy, Culture & Society*, 23(4), 1–21. <https://doi.org/10.1080/14681366.2015.1055128>.
- [48] Myers, S., Endres, M., Ruddy, M., & Zelikovsky, N. (2012). Psychology graduate training in the era of online social networking. *Train. Educ. Prof. Psychol.* 6(1), 28–36.
- [49] Nascimbeni, F., & Burgos, D. (2019). Unveiling the Relationship between the Use of Open Educational Resources and the Adoption of Open Teaching Practices in Higher Education. *Sustainability*, 11(20), 5637. DOI: <https://doi.org/10.3390/su11205637>.
- [50] Nascimbeni, F., & Burgos, D. (2016). ‘In search for the open educator: Proposal of a definition and a framework to increase openness adoption among university educators.’ *International Review of Research in Open and Distributed Learning*, 17(6). doi:10.19173/irrodl.v17i6.2736.
- [51] Nishigawa, K., & et al, O. K. (2017). Comparison between flipped classroom and team-based learning in fixed prosthodontic education. *Journal of prosthodontic research*, 61(2), pp.217-222.
- [52] OECD. (2015). *Schooling redesigned: Towards innovative learning systems*. Paris: OECD Publishing.
- [53] Ofcom. (2014). “Adults’ Media Use and Attitudes Report.” London: Ofcom. Accessed May 7, 2015. [http://stakeholders.ofcom.org.uk/binaries/research/media-literacy/adults-2014/2014\\_Adults\\_report.pdf](http://stakeholders.ofcom.org.uk/binaries/research/media-literacy/adults-2014/2014_Adults_report.pdf).
- [54] Ozdemir, O. &. (2017). ‘Turkish teachers’ awareness and perceptions of open educational resources.’ *Journal of Learning Development*, 4(3), 307–321.
- [55] Papert, S. (2001). Seymour Papert: Project-based learning. *Edu-topia*. Retrieved from <http://www.edutopia.org/seymour-papert-project-based-learning>.
- [56] Pappas, C. (2018). *eLearning Industry, The Top 10 Extended Enterprise Learning Management Systems (2020 Update)*. Retrieved from <https://elearningindustry.com/top-extended-enterprise-learning-management-systems-lms>
- [57] Peyton, J. K. (2010). *Evidence-based, Student choice instructional practices*. *Center for Applied Linguistic*. 20-25. Retrieved from <http://cal.org/caelanetwork>.
- [58] Pimmer, C., Linxen, S., & Grohbiel, U. (2012). “Facebook as a Learning Tool? A Case Study on the Appropriation of Social Network Sites from Mobile Phones in Developing Countries.” *British Journal of Educational Technology* 43 (5): 726–738. <http://onlinelibrary.wiley.com/doi/10.1111/j.1467-8535.2012.013>.
- [59] Prensky, M. (2002). The Motivation of Gameplay or, the REAL 21st century learning revolution. *Horizon* 2002, 10,.
- [60] Ranieri, M., Manca, S., & Fini., A. (2012). “Why (and how) do Teachers Engage in Social Networks? An Exploratory Study of Professional use of Facebook and its Implications for Lifelong Learning.” *British Journal of Educational Technology* 43 (5): 754–769.
- [61] Rapoport, S., Rubinsten, O., & Katzir., T. (2016). “Teachers’ Beliefs and Practices Regarding the Role of Executive Functions in Reading and Arithmetic.” *Frontiers in Psychology* 7: 20.
- [62] Septiani, A. P. (2017). Interactive and collaborative platform implementation on learning management system. In 2017 5th International Conference on Information and Communication Technology (ICoIC7) (pp. 1-6). IEEE.
- [63] Shachar, M. &. (2010). twenty years of research on the academic performance of differences between traditional and distance learning: Summative meta-analysis and trend examination. *Journal of Online Learning and Teaching*, 6(2), 318–334.
- [64] Shouder, T. I. (2014). “Listening to students: make learning spaces your own” *Change: The Magazine of Higher Learning*, Vol. 46 No. 1, pp. 26-27.
- [65] Siemens, G. &. (2018). *Connectivism and Connective Knowledge Online Course (CCK08)*. University of Manitoba, Canada. Retrieved from <https://web.archive.org/web/20080910010818/http://ltc.umanitoba.ca:83/wiki/Connectivism>.
- [66] So, W. M., Hung, H. K., & Yip, Y. W. (2008). The digital video database: A virtual learning community for teacher education. *Australian Journal of Educational Technology*, 24(1), 73–90.
- [67] Sobri, H., & Fatimah, W. (2012). The development of new conceptual model for mobile school. In: *Proceedings of the international conference on intelligent system and informatics (ISI 2012)* (Vol. 42), 14–16 November, Valetta, Malta.
- [68] Stracke, C. D. (2019). Are MOOCs Open Educational Resources? A literature review on history, definitions and typologies of OER and MOOCs. *Open Praxis*, vol. 11 issue 4, October–December 2019, pp. 1–11 (ISSN 2304-070X). DOI: <https://doi.org/10.5944/openpraxis.11.4.1010>.
- [69] Tess, P. A. (2013). The role of social media in higher education classes (real and virtual)—A literature review. *Computers in Human Behaviour*, 29(5), A60–A68.
- [70] UNESCO. (2015). *A Basic guide to open educational resources (OER)*. Retrieved from <https://unesdoc.unesco.org/ark:/48223/pf0000215804>.
- [71] Väljataga, T. P., & Tammets, K. (2011). Considering students’ perspectives on personal and distributed learning environments in course design. In M. J. Lee, & C. McLoughlin (Eds.), *Web 2.0-*

- based elearning: Applying social informatics for tertiary teaching (pp. 85-107). Hershey, PA: IGI Global.
- [72] Weller, M. (2007). *The distance from isolation. Why communities are the logical conclusion in e-learning. Computers & Education, 49, 148–159.*
- [73] Wheeler, S. (2010). Open content, open learning 2.0: using wikis and blogs in higher education. In *Changing cultures in higher education* (pp. 103–114). Heidelberg: Springer Berlin.
- [74] Wilson, H. K. (2016). Factors that influence students' satisfaction with their physical learning environments. *Structural Survey*.
- [75] Wu, D. D. (2015). Online learning in postsecondary education: A review of empirical literature (2013–2014). Ithaca S+R. Retrieved from <http://www.sr.ithaca.org/publications/online-learningin-postsecondary-education/>.
- [76] Yang, S. (2020). As teaching shifts online during the epidemic, it faces copyright issues.' Accessed on February 22, 2020, from: <https://news.cgtn.com/news/2020-02-20/Copyrightconcerns-as-teaching-shifts-online-during-epidemic-OejyJkh3xu/index.html>.
- [77] Yousef, A. M. (2015). MOOCs – A Review of the State-of-the-Art. CSEDU International Conference on Computer Supported Education 2014. Barcelona, Spain: April 2014. pp. 9–20. Retrieved 30 April 2015.
- [78] Yuan, L., & Powell, S. (2013). MOOCs and Open Education: Implications for Higher Education. JISC CETIS. Retrieved from <http://publications.cetis.org.uk/2013/667>.
- [79] Yung, H. W., Wong, S. L., Cheng, M. W., & Hui, C. S. (2007). Tracking pre-service teachers' changing conceptions of good science teaching: The role of progressive.
- [80] Zornić, D., & Hasanović, E. (2011). Uloga interakcije u online učenju [The Role of Interaction in Online Learning]. *Elektronski zbornik radova sa međunarodne konferencije YUINFO 2011*. Retrieved from <http://www.e-drustvo.org/proceedings/YuInfo2011/html/pdf/229.pdf>.



# Non-Dimensional Numbers Analysis Of A Grain Dryer

<sup>[1]</sup>Dhananjay Kumar, <sup>[2]</sup>Pinakeswar Mahanta, <sup>[3]</sup>Pankaj Kalita

<sup>[1]</sup>Department of Mechanical Engineering, Indian Institute of Technology Guwahati, Guwahati, India

<sup>[2]</sup>Department of Mechanical Engineering, Indian Institute of Technology Guwahati, Guwahati, India  
& Department of Mechanical Engineering, National Institute of Technology Arunachal Pradesh, Itanagar, India

<sup>[3]</sup>Centre for Energy, Indian Institute of Technology Guwahati, Guwahati, India

Email: <sup>[1]</sup>tak5dhananjay@gmail.com, <sup>[2]</sup>pinak@iitg.ac.in, <sup>[3]</sup>pankajk@iitg.ac.in

**Abstract**— The present study deals with the thermodynamic analysis of a natural convection crop dryer. This study has been performed mainly for the farmers of non-electrified areas of developing countries. The non-dimensional numbers analysis for the rectangular chamber has been performed for the two cases; (i) without sensible storage in the chamber, and (ii) sensible thermal storage medium is present in the rectangular chamber. This study has been performed to analyze whether the use of sensible thermal storage reduces the losses of energy from the brick wall of the rectangular chamber. The temperature and the non-dimensional numbers are plotted for both cases of studies. The average values of Grashof numbers, Rayleigh numbers, and Nusselt numbers were obtained as  $4.09 \times 10^9$ ,  $2.89 \times 10^9$ , 132.17 for the case-I while  $3.08 \times 10^9$ ,  $2.17 \times 10^9$ , 121.94 for the case-II, respectively. From the results, it is found that the values of the non-dimensional numbers are lower for the case-II. This indicates that the use of sensible energy storage (pebbles) is promising for the developed dryer.

**Keywords**— Natural convection, Heat transfer coefficient, energy analysis, exergy analysis

## I. INTRODUCTION

In the present scenario of the energy crisis, the energy and exergy analysis of any energy consumable systems become the most essential tools to optimize the energy consumption in the systems. Energy-exergy analysis can provide a significant solution to the energy crisis in the world. In the present situation, energy consumption increasing rapidly in daily life and we have very limited energy resources. Hence, the study of energy and exergy analysis of the biomass-operated grain dryer can extend the self-life of the energy resources. Numerous researchers reported the thermodynamic study of the various types of dryers. Kumar et al. [1] performed the thermodynamic study of a biomass-operated grain dryer and found that the sensible thermal storage medium reduces the exergy destruction in the natural convection dryer. Guerraiche et al. [2] performed a performance analysis of a solar collector using thermal storage. The thermal storage medium was used as a mixture of Sodium Nitrate (NaNO<sub>3</sub>) and Potassium Nitrate (KNO<sub>3</sub>). During the study, the outlet water temperature of the collector was obtained 14.86–16.80 % higher in the case of the thermal storage medium. Caliskan et al. [3] performed the first and second law thermodynamics study of a solar dryer using thermal storage for the ambient temperature of 8, 9, and 10 °C, respectively. This study was performed for the heating application of a building. In this study, the maximum value of the second law efficiency of the acquired thermal energy storage system was recorded as 88.78 % for the ambient temperature of 8 °C. Considering all components of the system, the maximum exergetic efficiency of the floor heating unit was obtained as 98.08%. Kumar et al. [4] studied the energy analysis in the rectangular chamber of a natural convection biomass-

operated grain dryer and observed that the thermal storage medium reduces the energy losses from the wall. Kalaiarasi et al. [5] presented the thermodynamic study of a solar air heater coupled with sensible thermal storage. This study was performed for two air mass flowrates 0.018 kg/s and 0.026 kg/s. The maximum value of thermal and exergetic efficiency was recorded as 49.4–59.2% and 18.25–37.53%, respectively for the airflow rate of 0.026 kg/s. Adetifa and Aremu [6] performed the experimental and numerical study of a thermal energy storage material. In this study, two latent storage medium and one sensible thermal energy storage medium were used for the low-temperature application. During the study, it was observed that the thermal storage material is capable to sustain 1.5 kg of water above 50 °C for 3 hours and 20 minutes in the absence of solar radiation. Kumar et al. [7] performed the exergy analysis in the rectangular chamber of a natural convection dryer and found that the thermal storage reduces the exergy losses from the wall of the rectangular chamber. Hence, this study enhances the performance of the dryer. Abuska et al. [8] reported the thermodynamic study of a solar collector coupled with sensible thermal storage. This study was performed to continue the use of solar collector even in the cloudy weather. This study was performed for the air flowrate range of 0.004–0.048 kg/s and the thermal efficiency was obtained in the range of 6.05–39.99 %. Senthil and Cheralathan [9] reported the study on the capacity enhancement of a thermal storage for a solar collector. In this study, sugar alcohol was used as a latent thermal storage and the thermal and exergetic efficiency were obtained as 66.7% and 13.8%, respectively.

In the literature, many researchers performed the thermodynamic analysis of solar dryers. The literature

related to the biomass operated dryer with thermal storage medium is found to be very limited. Hence, the objective of this study is to analyze the effect of the sensible storage medium on non-dimensional numbers of the natural convection biomass operated grain dryer. In the present analysis, the study is performed for the two cases; (i) without sensible thermal storage medium, and (ii) with sensible thermal storage medium in the rectangular chamber.

**II. EXPERIMENTAL SETUP AND PROCEDURE**

The experimental set up has been designed for the agricultural products drying process. The dryer consists of a rectangular chamber, paraffin wax tray, and drying tray having a dimension of 1.25 × 0.95 × 0.9 m, 1.25 × 0.95 × 0.12 m, and 1.25 × 0.95 m, respectively. Multiple holes in the conical furnace of dimension 0.6 × 0.3 × 0.68 m is kept in the rectangular chamber. Holes are made at the conical surface to flow the flue gases into the rectangular chamber. The flue gas exhaust pipe having a diameter of 6.35 cm is attached for the exhaust of flue gas. A provision of fresh air entry in the conical furnace is also made for the proper combustion of the biomass. The principle of this dryer working is buoyancy force. When the biomass burns in the furnace, hot air from the conical furnace flows into the rectangular chamber. This creates negative pressure in the furnace, which makes the cause of ambient air enters into the furnace, and combustion of the biomass continues. The experimental studies have been performed for the two cases; (i) There is no sensible storage medium (pebbles) in the rectangular chamber, (ii) sensible storage is present in the rectangular chamber. Fig. 1 shows the photograph of the natural convection crop dryer and Fig. 2 shows the schematic of the dryer.



**Fig. 1 Photograph of the dryer.**

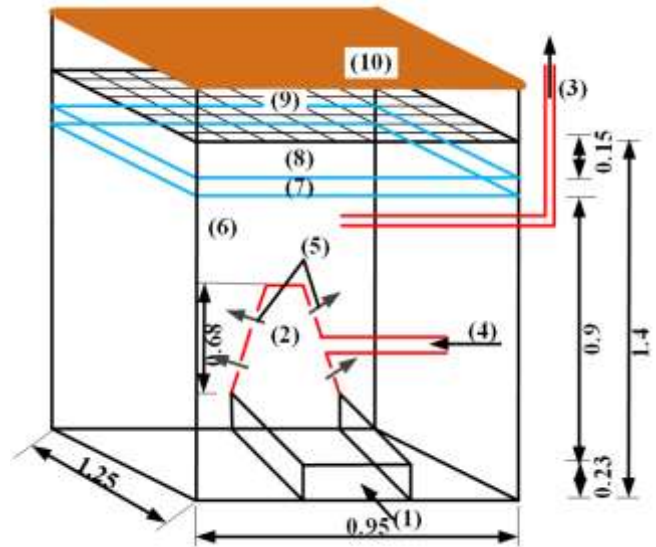

**Fig. 1 Schematic of the experimental setup**

- (1) Fresh air enters into the furnace
- (2) Conical furnace
- (3) Exhaust pipe (flue gas outlet)
- (4) Biomass feeding pipe
- (5) Flue gas enters into the chamber
- (6) Rectangular chamber (sensible storage)
- (7) Paraffin wax tray
- (8) Drying chamber
- (9) Drying tray
- (10) Mild steel cover

In both the cases of studies, biomass (lebbeck) has been burnt at the rate of 1.6 kg/h for three hours in the furnace. During the study, the temperature at the outer surface of the rectangular chamber (brick wall) is measured with the help of a Temperature Gun (GM-300).

**III. MATHEMATICAL FORMULATION**

This study has been performed to analyze the energy and exergy losses through the chamber. To evaluate the energy and exergy losses through the brick wall of the chamber, non-dimensional numbers and heat transfer coefficients calculation is important. Hence, the mathematical relations used in the evaluation of non-dimensional numbers and heat transfer coefficient are presented in this section. Grashof number (Gr) for the brick wall outer surface can be evaluated with the help of Eq. (1) [10][11]:

$$Gr = \frac{g \times \beta \times \Delta T \times L^3}{g^2} \tag{1}$$

Prandtl number can be written as in Eq. (2):

$$Pr = \frac{\mu \times c_p}{k} \tag{2}$$

Rayleigh number is evaluated with the help of Eq. (3) [4]:

$$Ra = Gr \times Pr \tag{3}$$

Nusselt number is calculated with the help of Eq. (4) [12]:

$$Nu = 0.10 \times Ra^{0.333} \tag{4}$$

IV. RESULTS AND DISCUSSION

In the present study, all the experimental data have been recorded at an interval of 0.5 hours. The subscripts 1 & 2 represent the case-I and case-II, respectively. Fig. 3 shows the Grashof numbers variations for the case-I and case-II. From the results, it has been found that the values of Grashof numbers are higher for the case-I. From the figure, it has been realized that the Grashof numbers curves follow the trends of the temperature curve. The Rayleigh numbers variations is shown in Fig. 4 and the Nusselt number is shown in Fig. 5. From the Figs. (4 & 5), it has been found that the Rayleigh numbers and the Nusselt numbers are higher for the case-I and these curves follow the same trend as Grashof numbers. The average value of the Rayleigh and Nusselt numbers are obtained as  $2.89 \times 10^9$  and 132.17 for the case-I and  $2.17 \times 10^9$  and 121.94 for the case-II, respectively.

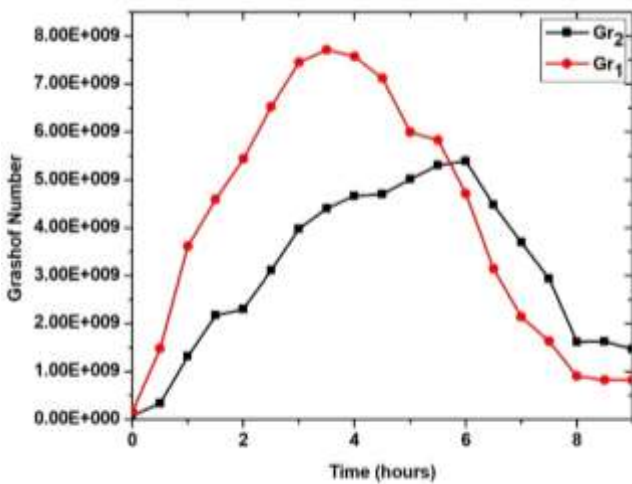

Fig. 3 Grashof numbers variations.

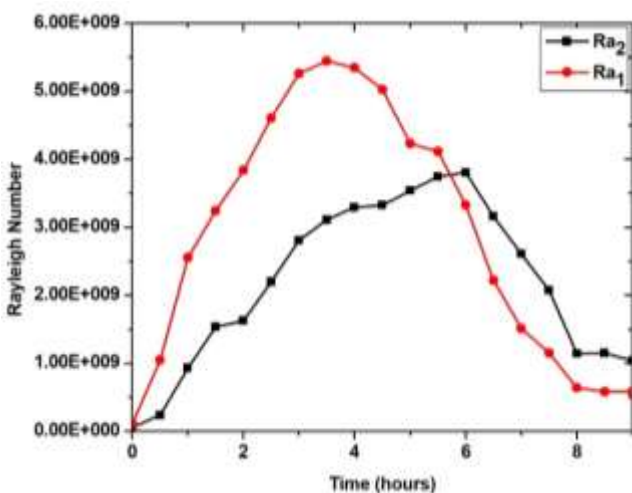

Fig. 4 Rayleigh numbers variation curve.

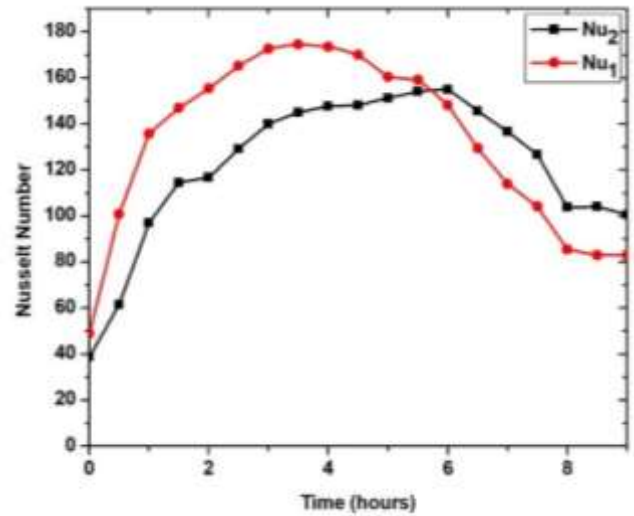

Fig. 5 Nusselt numbers variation curve.

Figs. (6 & 7) shows the variations of Grashof and Nusselt numbers for the cases-I & II), respectively. From the figures, it has been observed that the Grashof and Nusselt numbers vary with similar trends, and relatively lower values of both non-dimensional numbers were obtained in the case-II. From the results, it has been found that the maximum values of the non-dimensional numbers for the case-I were obtained at the 6 hours of the study, while the same was obtained at 4 hours for the case-II.

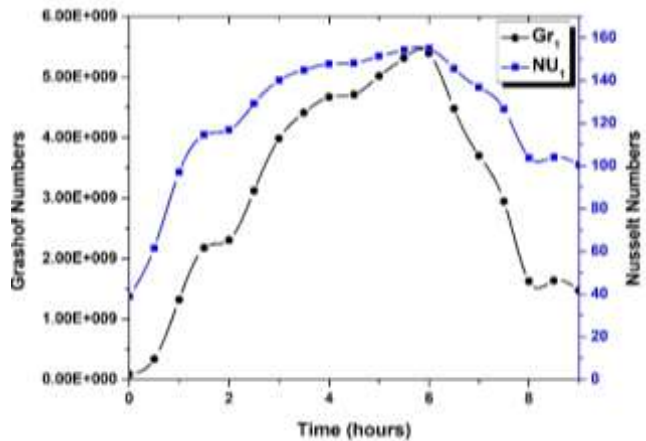

Fig. 6 Grashof and Nusselt numbers variations for case-1.



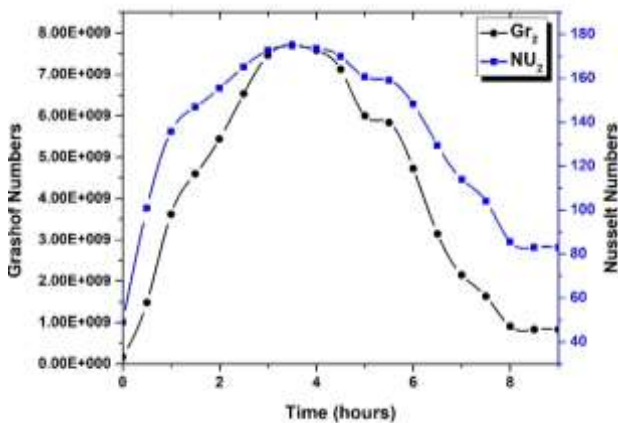

Fig. 7 Grashof and Nusselt numbers variation with time for case-2.

V. CONCLUSIONS

This study has been performed to analyze the performance of the developed dryer with the use of a sensible thermal storage medium in the rectangular chamber. From the results obtained in the present study, it has been found that the sensible energy storage material reduces the values of the non-dimensional numbers at the surface of the rectangular chamber. The lower values of the Nusselt numbers indicate that the sensible storage medium reduces the energy losses from the brick wall of the chamber. Hence, the use of a sensible storage medium (pebbles) is highly recommendable for the application.

Acknowledgment

The authors express sincere gratitude to the Department of Mechanical Engineering, IIT Guwahati for the financial support to develop the experimental set-up.

REFERENCES

[1] D. Kumar, P. Mahanta, P. Kalita, Energy and exergy analysis of a natural convection dryer with and without sensible heat storage medium, *Journal of Energy Storage*. 29 (2020). <https://doi.org/10.1016/j.est.2020.101481>.

[2] D. Guerraiche, C. Bougriou, K. Guerraiche, L. Valenzuela, Z. Driss, Experimental and numerical study of a solar collector using phase change material as heat storage, *Journal of Energy Storage*. 27 (2020) 101133. <https://doi.org/10.1016/j.est.2019.101133>.

[3] H. Caliskan, I. Dincer, A. Hepbasli, Energy and exergy analyses of combined thermochemical and sensible thermal energy storage systems for building heating applications, *Energy and Buildings*. 48 (2012) 103–111. <https://doi.org/10.1016/j.enbuild.2012.01.017>.

[4] D. Kumar, P. Mahanta, P. Kalita, Thermodynamic analysis of a natural convection dryer, in: P.H. and B.N.H. Yengkhom Disco Singh, Helen Soibam (Ed.), *Post Harvest Technology and Value Addition, Vol-1,*

Iss, The Dean, College of Horticulure & Forestry, Central Agricultural University, Pasighat-791102, Arunachal Pradesh., 2019: pp. 156–61. <https://doi.org/ISBN 978-93-5396-087-2>.

[5] G. Kalairasi, R. Velraj, M. V Swami, Experimental energy and exergy analysis of a fl at plate solar air heater with a new design of integrated sensible heat storage, *Energy*. 111 (2016) 609–619. <https://doi.org/10.1016/j.energy.2016.05.110>.

[6] B.O. Adetifa, A.K. Aremu, Computational and experimental study of solar thermal energy store for low- temperature application, *Journal of Energy Storage*. 20 (2018) 427–438. <https://doi.org/10.1016/j.est.2018.10.021>.

[7] D. Kumar, P. Mahanta, P. Kalita, Exergy analysis of a natural convection grain dryer, in: I. Dr. Satyender Singh (NIT Jalandhar (Ed.), *Energy Storage Systems; An Introduction*, Nova science publishers, 2020. <https://doi.org/ISBN: 978-1-53618-873-8>.

[8] M. Abuşka, S. Şevik, A. Kayapınar, Comparative energy and exergy performance investigation of forced convection solar air collectors with cherry stone/powder, *Renewable Energy*. 143 (2019) 34–46. <https://doi.org/10.1016/j.renene.2019.04.149>.

[9] R. Senthil, M. Cheralathan, Enhancement of the thermal energy storage capacity of a parabolic dish concentrated solar receiver using phase change materials, *Journal of Energy Storage*. 25 (2019) 100841. <https://doi.org/10.1016/j.est.2019.100841>.

[10] P K Nag, *Heat and Mass Transfer*, Third Edit, McGraw Hill Education (India) Private Limited, New Delhi, 2014.

[11] D. Kumar, P. Mahanta, P. Kalita, Natural convection grain dryer, in: I. Dr. Satyender Singh (NIT Jalandhar (Ed.), *Energy Storage Systems; An Introduction*, Nova science publishers, 2020. <https://doi.org/ISBN: 978-1-53618-873-8>.

[12] L. Evangelisti, C. Guattari, P. Gori, F. Bianchi, Heat transfer study of external convective and radiative coefficients for building applications, *Energy and Buildings*. 151 (2017) 429–438. <https://doi.org/10.1016/j.enbuild.2017.07.004>.



# User-Query Processing through Dynamic Tweets Status Recommender System

<sup>[1]</sup> V. Kakulapati, <sup>[2]</sup> D. Vasumathi, <sup>[3]</sup> G. Suryanarayana

<sup>[1]</sup> SNIST, Yamnampet, Ghatkesar, Hyderabad, Telangana, India

<sup>[2]</sup> JNTUCE, Kukatpally, Hyderabad, Telangana, India

<sup>[3]</sup> CMRCET, kondalakoya, Medchal, Hyderabad, Telangana, India

Email: <sup>[1]</sup> vldms@yahoo.com, <sup>[2]</sup> rochan44@gmail.com, <sup>[3]</sup> surya.aits@gmail.com

**Abstract**— With increasing user information volume in online social networks, recommender systems have been an effective method to limit such information overload. The requirements of recommender systems specified, with widespread adoption in many internet social Twitter, Facebook, and Google online applications. In recent years, the micro-blogging in Twitter has brought greater importance to online users as a channel spreading knowledge and information. Through Twitter, users can find the relevant information on the search they perform, but understanding the past, present, and future information relevant to the investigation source is needed real-time information. Estimating the successful tweet status (history, ongoing, and prospective) among the huge population of Twitter members is important to satisfy the needs of Twitter online content readers. In this paper, a Dynamic Tweets Status Recommender System (DTSRS) is designed by creating a set of dynamic recommendations to a Twitter user based on usability, consisting of people who post tweets, which is exciting present and future. The proposed recommender system is implemented through two approaches: the first is to analyze the Twitter member online tweets, select and understand the content of that tweet, and the second predicts the understanding of the tweet content, suggest the dynamic status of the tweets. In this paper, the Twitter user tweets' views are expressed after examining the depth of content, different types of user interfaces, text filtering, and machine learning technique. The set of results through tweets experimentations with database operators carried out to evaluate and comparability the proposed recommender system's performance.

**Keywords**— tweets, micro-blogging, context-aware, user query, recommender system

## I. INTRODUCTION

With the development of internet information applications in the present technology, the social internet has become an essential behavioral channel for social users to access rapidly moving information [1]. Such social networks are the origins of many millions of social communications in the real-time world, such as blogs, reviews, tweets, updates, and much more [2][3]. The content-based recommender systems are incorporated in traditional recommender systems in an efficient approach to improve the accuracy and relevancy of the user social internet applications. Current recommender systems [4][5][6] are limited to cope up with static user preferences, could able to analyze the content adopt the learning system based on the query generated. The dynamic user preferences-based recommender system is needed to quickly and efficiently understand and find the content the user is most likely interested in and provide the recommendation based on the learning system, which is personalized.

### 1.1. Motivation

From the above issues, a Dynamic Tweets Status Recommender System provides the content based on user preference and interest by analyzing the user tweets' historical and present behavior and user tweets sharing content as relevant information. Dynamic tweets are recommended, which best suits the user query interests and tweets logs information. The overload problems of data to analyze and retrieve become less and make the search

engine post the user tweets based on the dynamic and personalized way, by providing explicit and exact requirements.

The Dynamic Tweets Status Recommender System is designed to quickly extract the user tweets information, with an efficient content-aware understanding, access to tweets that best-fit most from the overloaded user

tweets internet information having tweets mining capability in potential user interests. The benefit of the proposed Dynamic Tweets Status Recommender System is that the user no longer needs to spend much time searching the tweets information, making the time-saving effort too low and proving the tweets' dynamics to the user, making the efforts to reduce and increases the user's satisfaction.

### 1.2. Challenges

The challenges are:

- The tweet and retweet posts are to be analyzed, which are widespread. Proper analysis of these posts can provide the user's interactions.
- The user interface device is length restricted to 140-characters, making the user follow the tweets independently. Specific user tweets can provide the dynamics of tweets posted.
- The tweets' replicates are less than the unidirectional tweets, which makes the source of information in one

direction, the importance of the tweet can be interpreted with the original tweet.

- d) The user-query decision for the tweet is abundant, making the user experience ambiguity in decision-making. Filtering tweets based on personal recommendations can result in a small amount of relevant data.

### 1.3. Objectives of the Proposed Work

The contributions of the proposed Dynamic Tweets Status Recommender System are:

- a) To thoroughly review the literature on the advance of deep learning and machine learning recommender systems.
- b) Designing a dynamic classifier for generating tweets provides the tweets information recommendations to the interested users.
- c) To design a tweets status profiler for structuring the user status through the published tweets, the user recommended followers belonging to the user's tweets content sharing interests.
- d) Develop a Dynamic Tweets Status Recommender System in providing the user tweet dynamics in a useful and privacy mode, which gives the past, present, and future tweets status.

The remaining document is structured as, Section II explains the associated work for the user-quest recommendation framework. The proposed work is listed in Section III. Section IV provides findings and debates and Section V draws conclusions.

## II. RELATED WORKS

Recommendation Systems provide services through AI (Artificial Intelligence) and NLP (Natural Learning Processing) to provide the required evaluated explanations for the user's recommendations in several social network application networks and services [7][8]. User interface like mobile website applications enables different content related to movies, food, books, YouTube videos, health, etc. The social community moves towards movies, music, and entertainment. The recommendation system [9], based on user visibility to the content, still has security and privacy challenges. Therefore, the traditional recommendation systems [10] have become inevitable to the present user reviews and tweets in the decision making of user content [11][12].

Recommender system for Twitter with micro-blogging service makes users tweet and retweet with the length of 140 characters, named status updates of user tweets [13]. The relation between these tweets is unidirectional as the registered user tweets the tweet and another user who retweet follows the tweeting user. The list of the followed user pertains to the retweeting user only. Tweets have context and content related to the user's particular interest,

such as movies, music, or specific of the said above [14]. The user who tweets is the source of information, and the user who retweet is the source of follower information, helps in analyzing the content of tweets. The micro-blogging is a way to communicate for comprehensive news spread through the user tweet channel. The Twitter users are categories into three: the first is relevant to tweets information sources, in which users are categorized into a large number of follower tweets. The second applies to tweets information seekers, in which users post a rare tweet for understanding the tweet content and follow them regularly, and the third is relevant to the relationship of user tweets [15] like friends, relatives, in which the personal tweets are retweet content.

The above categories are ranked based on the users, followers, and similar results among the tweet and retweet [16]. The ranking is made on several users, several followers, and the retweets with the recommended information sources and seekers. The orders based on these forms the popularity of relative tweets among the users and followers, including influence indicators in tweets decision making [17]. The rankings are ordered as first for tweets and retweet users, second influence user with significant influence over tweets categories, and third retweet relationship with the content of sharing in the reviews mentioned [18]. Later, these rankings are analyzed for similarity and link structure to identify the tweets network by providing proper weight to the popular tweet, which influences the connected user's ranking for different content sharing relationships [19].

The ranked tweets are focused on analyzing the URLs of the user tweets to structure the source of the tweet based on user preference and profiling with the information streamed at the recommender system based on the two interests: one is target retweet user, and the other is social content analysis with the recommended URLs for the analyzed content in the tweet recommendations [20][21]. The URLs carrying the specific tweets feeds are considered for tweet user and retweet user preferences, to analyze for mapping against their URLs tweeted and from the time of relationship made among the users in the recent tweet content ranking. The analyzed URLs address real-time tweet and retweet opinion tracking with the expressed tweets [22] with the reviews and recommendations, on the preference of information-based or content-based or with the collaborative based user tweet filtering recommendation.

In addressed URLs, the potential and relevant content of micro-blogging tweets are recommended to interested users to follow. In the recommendation procedure[23], the volume of information recommended is classified on the basis: small amount of tweet content based on the role of a user during the emergency events, medium amount of tweet content based on multiple profile strategy[24] [25] representing the broadcast of the content under the filter approach and a large amount of tweet content based on the target user in hybrid system to index the Twitter profile

users through the explored range to find the accurate user through user interest assessment and personal recommendations.

Finally, the tweet content based on the profile strategy is indexed with user-queries to find tweets online on social networks. The indexed user-query recommends related tweets reflecting in different Twitter sources, with the content-based profile strategy [26] in making the user recommendations according to the observed user's interaction [27] and relationship with the structured data through dynamic user-generated content sharing from Twitter.

III. PROPOSED WORK

In this paper, a Dynamic Tweets Status Recommender System is designed through a dynamic classifier and tweets status profiler to follow the recommendation of Twitter, which provides the past, present, and future tweets status. The user's profile content includes necessary information about the user, user recommendations, user tweets, and user retweets in a dynamic classifier. The factors of user interaction time with friends, social, and relationship are analyzed. In the tweet's status profiler, user behavior and affected contextual circumstances are diagnosed with mood and social life with the geographical locations.

3.1 Objective

This research paper aims to provide user tweet classification based on users' social, cultural, geographical, physiological, and economic, with the user's particular needs and provide the estimation of the dynamic (i.e., past, present, and future) tweets status.

A Dynamic Tweets Status Recommender System is designed and performed sentimental analysis on user-query with tweet and retweet content processing of different tweet status changes of user query preferences and tastes to achieve this objective.

3.2 Methodology

To design the proposed Dynamic Tweets Status Recommender System, the methodology used are listed below:

- 3.2.1 To analyze the query and user profile using the representation method of annotation categories.
- 3.2.2 To estimate the URLs web page recommendation through popularity using the web query method of similarity degree.
- 3.2.3 To link the tweets and retweets relationships specific to a user social network using the followers on a social network.
- 3.2.4 To generate a probabilistic content model that indexes the tweets and retweets through a dynamic tweet, relevant social importance factors.

3.2.5 Training the proposed recommended system and validating the dynamic classifier using the user-tweets.

3.2.6 Compared with current recommendation structures of the calculated outcomes of the proposed systems.

Table 1 exhibits the proposed methodology

Table 1: Proposed work Methodology Steps

<b>User-Twitter-Data gathering</b>	
Tweets	Retweets
<b>Pre-processing</b>	
Emotions	Opinions
<b>Training data</b>	
Key-based tweets dataset	Cleaned tweet
<b>Classification</b>	
POSITIVE	NEGATIVE
<b>Feedback mechanism</b>	
Sentiment scope	Relevant Process
<b>Recommender System</b>	
Content analysis	Behavioral analytics

3.3 Design and Implementation

The proposed Dynamic Tweets Status Recommender System uses the users shared opinions and reviews for the micro-blogging services that helps in tweets and retweets decision making under Positive, Negative and Neutrality based on extracted opinion mining, where the emotions of users are extracted by semantic analysis of the user's review by the LSTM machine learning algorithm.

The proposed Dynamic Tweets Status Recommender System is shown in figure 1.

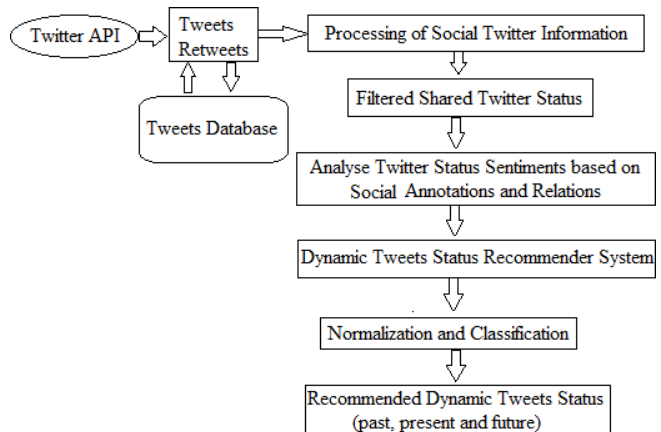

Figure 1: Proposed User Interface development diagram.

In figure 1, the Twitter data is collected from the registered Twitter API and performs the tweets and retweets collection process through hashtags and keywords. In this work, the data were collected for the reviews of social status in 2019-2020. Tweets are collected based on the

keywords associated with health, money, and job. The statistical tool R is used to collect the tweets and perform the analysis part required for proposed recommender system implementation. MongoDB database has been used to store the tweets, which is used as a content storage database. The tweets are retrieved from the user Twitter API and saved in MongoDB for sentiment analysis, further performing the tweets analysis.

### 3.4 Dynamic Tweets Status Recommender System

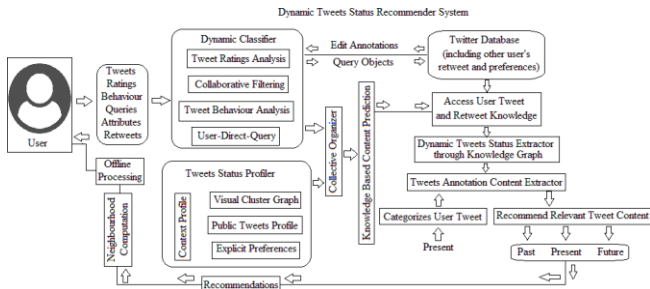

Figure 2: Proposed Dynamic Tweets Status Recommender System Flow Diagram

Figure 2 shows the proposed work; the Dynamic Classifier and Tweets Status Profiler design is shown in Algorithm 1 and 2, respectively. Algorithm 1 is responsible for limiting past tweets with recent/present tweets/user actions. This algorithm implements the user-query identity under the tweets decision tree graph. If millions of active tweets are available at this stage, they are clustered into minimal numbers based on ratings and behavior, with a minimum of up to 100 tweets. And there become the user's new tweets, forming only the present user tweets with the new list. And this method also reduces the time for extraction for similar tweets and retweets, causing to eliminate the redundancy in the tweet's submission. Algorithm 1: Dynamic Classifier

- 1) computeUserprofileClassQuery
- 2) INPUT: u (user)
- 3) O (set of past tweets)
- 4) OUTPUT: Ou (set of users under past tweets)
- 5) Begin
- 6)  $T \leftarrow \{ x : \text{is a user tweet attribute} \}$
- 7)  $\text{tuple} \leftarrow \text{-pr1, prn} \{ \text{pr} : \text{is set of present tweets} \}$
- 8)  $O \leftarrow \{ x : \text{tuple} \{ \text{set of present tweet attributes} \} \}$
- 9)  $A \leftarrow \{ x : \text{recent active past tweets} \}$
- 10) if ( $A \neq \Phi$ );
- 11) isPresent $\leftarrow$ True
- 12) return isPast
- 13) End

Algorithm 2 is Tweets Status Profiler, the similarities in the user profiles are computed, with the given list of profiles, the similarity between the user profiles list n relation to the particular tweets user information is extracted and

compared with the knowledge of the tweets posted earlier, to recommend the past and future tweets in the relevant knowledge graph to map with the tweet content. The algorithm is called Status Similarity, which compares with the similarity between history and future user profile tweets.

#### Algorithm 2: Tweets Status Profiler

- 1) computeStatusProfile
- 2) INPUT u (user)
- 3) O (set of past and present tweets)
- 4) OUTPUT: S (set of similar profiles)
- 5) Begin
- 6)  $T \leftarrow \{ x : \text{is a user tweet attribute} \}$
- 7)  $O \leftarrow \{ x : \text{tuple} \{ \text{set of present tweet attributes} \} \}$
- 8)  $\text{tuple} \leftarrow \text{-pa1, pan} \{ \text{pr} : \text{is set of past tweets} \}$
- 9)  $\text{tuple} \leftarrow \text{-fu1, fun} \{ \text{fu} : \text{is set of future tweets} \}$
- 10)  $P \leftarrow \text{computeProfileStatus}(u, O)$
- 11)  $A \leftarrow \{ \text{set of past tweets as isActive} \}$
- 12)  $B \leftarrow \{ x : \text{recent future tweets} \}$
- 13) if ( $B \neq \Phi$ );
- 14) isPresent $\leftarrow$ True
- 15) return isFuture
- 16) isPresent $\leftarrow$ False
- 17) return isPast
- 18)  $q \leq 0.5$ : similarity index for user profiles
- 19)  $S \leftarrow \{ s : s \in A \text{ AND StatusSimilarity} \{ s, u \} \geq q, \forall s \}$
- 20) return S
- 21) End

### IV. COMPARATIVE RESULTS AND DISCUSSIONS

The proposed Dynamic Tweets Status Recommender System is evaluated with online Twitter information. In the proposed work experiment, the algorithms are integrated with social networks for understanding and analyzing. The user's profiles are implemented at the user locations with the Mozilla Browser Platform. The proposed system evaluation's user profile content contains location, time, followers, relationships, age, profile summary, tweets, and retweets. The abundant user's information is passed to knowledge discovery to attain the relevant information to the recommendation system. The user interaction with the tweets and retweets through the proposed recommendation system was provided with logins and logouts by saving them as a log file. The recommended user information is stored in its ID that offers the users recommendations with the tweets and recommended friends or recommended user retweets, concerning the time taken in the said above process called recommendation time for user tweets to analyze and predict.



### 3.5 Experiments

The proposed recommendation system is based on accuracy, which is predictive and comparative. The accuracy evaluation score states a better recommendation system. The survey literature includes several recommendation systems, having their own method of design and analysis. One standard process involves is the tweets sentiment analysis and classifier design. This is evaluated among different approaches with the proposed method, through an offline analysis, which is satisfactory to all the recommended systems. During the offline evaluation, the user tweets are attributed to the algorithms' performance, and the dataset is stored in .csv format to record the past, present, and future tweets using the conversion rate metric.

### 3.6 Evaluation Metrics

The measurement metrics for weighing, retrieving and f-measuring the proposed method accuracy. The accuracy, recall and f-measure relationships are given below:

$$\text{Precision} = \frac{\text{TRT (total number of recommended tweets)}}{\text{NT (number of tweets)} + \text{TRT}} * 100 \%$$

$$\text{Recall} = \frac{\text{TRT}}{\text{NTT (number of target tweets)} + \text{TRT}} * 100 \%$$

$$F - \text{measure} = 2 * \frac{\text{Precision} * \text{Recall}}{\text{Precision} + \text{Recall}}$$

$$\text{Accuracy} = \frac{\text{TP} + \text{TN}}{\text{TP} + \text{TN} + \text{FP} + \text{FN}}$$

Where, TP (True Positives) , TN (True Negatives), FP (False Positives) and FN (False Negatives).

To evaluate the test results of the classifier with the sampling techniques shown in Table 2 for classifying tweets, the truth-positive, true negative, false positives, and false negative parameters are used.

**Table 2: System for metric analysis Classification matrix**

Predicted Class (Observations)	Actual Class (Expectation)	
	TP Precise Result	FP Unexpected Result
	FN Missing Result	TN Correct absence of result

### 3.7 Analysis

The experiments are carried through volunteer 27users, with 17 males and 10 females Twitter user members to evaluate the proposed recommender system. The recommender system is implemented using Java SDK, WordNet Version 3.0, for classifier design and analysis. The Weka tool of version 3.6 is used, and the computer system hardware configuration tool is Intel (R) Core i5-3230M CPU @2.60 GHz with 8 GB RAM of 64-bit Operating System. The evaluation of 27 users is made by allowing them to use the proposed recommender system on their desktops to analyze their own topic or tweet information. Table 3 presents the sample of 27 users' identifications and categories.

For each user, the field of information made available in public is name, description, profile image, tweets, retweets, and profile link with the corresponding profile interests. During the implementation part, each user is made to evaluate the proposed recommendation was relevant or not and decide the system through retweets. Table 4 presents the Twitter likes of the tweets category from reviews.

**Table 3: User ID and tweet category**

User ID	Tweet Category	Tweet title	Reviews of user about Tweet title
User1	Science	The Quantum theory	Is a fundamental theory in physics
User7	Movie	Godzilla	Is an enormous, destructive, prehistoric sea monster
User12	Sport	Football	Modern football originated in Britain in the 19th century
User19	Environment	Garden	Natural elements present in a garden
User27	Space	Stars	Stars are classified by their spectra and their temperature.

**Table 4: User ID, tweet category from twitter likes**

User ID	Tweet Category	Semantic Emotions	Twitter likes
User1	Science	Highly Favourable	31567K
User7	Movie	Highly Favourable	56489K
User12	Sport	Average Favourable	21359K
User19	Environment	Highly Favourable	49125K
User27	Space	Average Favourable	20458K

Table 5 and Table 6 presents the comparison of the proposed recommender system and other survey models mobile movie recommendation service [MMRS] [15], sentiment-enhanced hybrid recommender system [SHRS][24], movie recommendation system [MRS][19], a deep temporal neural music recommendation model [DNMRM][8], multivariant expert system [MES][14]and multivariate System [MVS][16]. The F score results for the proposed recommender system are compared with other parameters and other recommendation systems. The accuracy of the proposed Dynamic Tweets Status Recommender System is 99.1 %, stating the tweets categories are genuinely interested in users. With a true positive rate of 99.46 %, the recommendation system makes interest to those intended and recommended users only.

**Table 5: A comparison of the various judgment criteria of the recommendation**

Decision Parameters	TP	TN	FP	FN
MES	442	387	114	57
SHRS	375	355	95	175
MRS	406	347	116	131
DNMRM	525	250	90	135
MMRS	341	237	207	215
MVS	554	433	8	5
<b>Proposed DTSRS</b>	<b>556</b>	<b>435</b>	<b>6</b>	<b>3</b>

**Table 6: Results of the experiments**

	MES	SHRS	MRS	DNMRM	MMRS	MVS	Proposed DTSRS
<b>Precision</b>	0.7950	0.7979	0.7778	0.8537	0.6223	0.9858	0.9893
<b>Recall</b>	0.8858	0.6818	0.7561	0.7955	0.6133	0.9911	0.9946
<b>F score</b>	0.8379	0.7353	0.7668	0.8235	0.6178	0.9884	0.9919
<b>Accuracy</b>	0.8290	0.7300	0.7530	0.7750	0.5780	0.9870	0.9910

## V. CONCLUSIONS

In this paper, a Dynamic Classifier and Tweets Status Profiler algorithms are proposed to design Dynamic Tweets Status Recommender System. The experiments are implemented with the user tweets in a Java environment with a classifier library to improve the response time and generate the proper recommendations. During the implementation, the proposed recommender system used opinion polling and sentiment analysis to extract user past, present, and future recommender tweets in order and rank based. Therefore, significant recommendations are derived efficiently using the LSTM learning algorithm, which increased tweets' classification towards the past, present, and future user tweets categories mentioned in the simulation analysis. The simulation results of experiments show the proposed recommender system has comparative improvements of the recommender systems to apply in the tweets sentence-level and content level.

## VI. FUTURE WORK

The proposed Dynamic Tweets Status Recommender System can be further enhanced by including more user tweet profile parameters like movie playlist, Twitter user groups, tweets sessions, user emotions, user tweet tags, and the feature retweet content to improve the recommender system.

## REFERENCES

- [1] Chen, J., Nairn, R., Nelson, L., Bernstein, M., Chi, E.: Short and tweet: experiments on recommending content from information streams. In: Proc. of the 28th Int. Conf. on Human Factors in Computing Systems (CHI'10). pp. 1185–1194 2010.
- [2] Crisci, V. Grasso, P. Nesi et al., "Predicting TV programme audience by using Twitter based metrics," *Multimedia Tools and Applications*, vol. 77, no. 3, pp. 12203–12232, 2018.
- [3] E. Mohammadi, M. elwall, M. Kwasny, and K. L. Holmes, "Academic information on twitter: a user survey," *PLoS One*, vol. 13, no. 5, Article ID e0197265, 2018.
- [4] Esparza, S.G., O'Mahony, M.P., Smyth, B.: On the real-time web as a source of recommendation knowledge. In: Proc. of the 4th ACM Conf. on Recommender Systems (RecSys'10). pp. 305–308 2010.
- [5] F. Emmert-Streib, O. P. Yli-Harja, M. Dehmer, and F. Emmert-Streib, "Data analytics applications for streaming data from social media: what to predict?" *Frontiers in Big Data*, vol. 1, p. 2, 2018.
- [6] Garcia, R., Amatriain, X.: Weighted content based methods for recommending connections in online social networks. In: Workshop on Recommender Systems and the Social Web. pp. 68–71. Barcelona, Spain 2010.
- [7] H. Li, D. Caragea, C. Caragea, and N. Herndon, "Disaster response aided by tweet classification with a domain adaptation approach," *Journal of Contingencies and Crisis Management*, vol. 26, no. 1, pp. 16–27, 2018.
- [8] H.-T. Zheng, J.-Y. Chen, N. Liang, A. K. Sangaiah, Y. Jiang, and C.-Z. Zhao, "A deep temporal neural music recommendation model utilizing music and user metadata," *Applied Science*, vol. 9, no. 4, p. 703, 2019.
- [9] Java, A., Song, X., Finin, T., Tseng, B.: Why we twitter: understanding microblogging usage and communities. In: Proc. of the 9th WebKDD and 1st SNA-KDD 2007 Workshop on Web Mining and Social Network Analysis. pp. 56–65 2007.
- [10] Joachims, T., Granka, L., Pan, B., Hembrooke, H., Gay, G.: Accurately interpreting click through data as implicit feedback. In: Proc. of the 28th Int. ACM SIGIR Conf. on Research and Development in Information Retrieval (SIGIR'05). pp. 154–161 2005.
- [11] Kwak, H., Lee, C., Park, H., Moon, S.: What is Twitter, a social network or a news media? In: Proc. of the 19th Int. Conf. on World Wide Web (WWW'10). pp. 591–600 2010.
- [12] Liben-Nowell, D., Kleinberg, J.: The link prediction problem for social networks. In: Proc. of the 12th Int. Conf. on Information and knowledge management. pp. 556–559. CIKM '03, ACM, New York, NY, USA 2003.
- [13] M. Gao and X. Zhang, A movie recommender system from tweets data, January 2019, [http://cs229.stanford.edu/proj2015/299\\_report.pdf](http://cs229.stanford.edu/proj2015/299_report.pdf).
- [14] [14]. M. Ibrahim and I. Bajwa, "Design and application of a multivariant expert system using apache hadoop framework," *Sustainability*, vol. 10, no. 11, p. 4280, 2018.
- [15] M.-Y. Hsieh, W.-K. Chou, and K.-C. Li, "Building a mobile movie recommendation service by user rating and APP usage with linked data on Hadoop," *Multimedia Tools and Applications*, vol. 76, no. 3, pp. 3383–3401, 2017.
- [16] Muhammad Ibrahim, Imran Sarwar Bajwa, Riaz Ul-Amin, and Bakhtiar Kasi, "A Neural Network-Inspired Approach for Improved and True Movie Recommendations", *Hindawi, Computational Intelligence and Neuroscience*, Volume 2019, pp-1-19.
- [17] O. Loyola-González, A. López-Cuevas, M. A. Medina-Pérez et al., "Fusing pattern discovery and visual analytics approaches in tweet propagation," *Information Fusion*, vol. 46, pp. 91–101, 2018.

- [18] Phelan, O., McCarthy, K., Smyth, B.: Using Twitter to recommend real-time topical news. In: Proc. of the 3rd ACM Conf. on Recommender Systems (RecSys'09). pp. 385–388 2009.
- [19] S. Kumar, S. S. Halder, K. De, and P. P. Roy, "Movie recommendation system using sentiment analysis from microblogging data," 2018, <https://arxiv.org/abs/1811.10804>.
- [20] S. Stieglitz, M. Mirbabaie, B. Ross, and C. Neuberger, "Social media analytics—challenges in topic discovery, data collection, and data preparation," *International Journal of Information Management*, vol. 39, pp. 156–168, 2018.
- [21] Tang, J.; Belletti, F.; Jain, S.; Chen, M.; Beutel, A.; Xu, C.; Chi, E.H. Towards Neural Mixture Recommender for Long Range Dependent User Sequences. In Proceedings of the World Wide Web Conference, WWW 2019, San Francisco, CA, USA, 13–17 May 2019; pp. 1782–1793.
- [22] Wang, S.; Cao, L.; Wang, Y. A Survey on Session-based Recommender Systems. arXiv 2019, arXiv:1902.04864.
- [23] Wu, S.; Tang, Y.; Zhu, Y.; Wang, L.; Xie, X.; Tan, T. Session-Based Recommendation with Graph Neural Networks. In Proceedings of The Thirty-Third AAAI Conference on Artificial Intelligence, AAAI 2019, Honolulu, HI, USA, 27 January–1 February 2019; pp. 346–353.
- [24] Y. Wang, M. Wang, and W. Xu, "A sentiment-enhanced hybrid recommender system for movie recommendation: a big data analytics framework," *Wireless Communications and Mobile Computing*, vol. 2018, Article ID 8263704, 9 pages, 2018.
- [25] Y. Wu, M. Qi, and R. Yang, "A news recommendation system based on an improved collaborative filtering algorithm," (in Chinese), *Comput. Eng. Sci.*, vol. 39, no. 6, pp. 11791185, 2017.
- [26] Yuan, F.; Karatzoglou, A.; Arapakis, I.; Jose, J.M.; He, X. A Simple Convolutional Generative Network for Next Item Recommendation. In Proceedings of the Twelfth ACM International Conference on Web Search and Data Mining, WSDM 2019, Melbourne, Australia, 11–15 February 2019; pp. 582–590.
- [27] Zhang, S.; Yao, L.; Sun, A.; Tay, Y. Deep Learning Based Recommender System: A Survey and New Perspectives. *ACM Comput. Surv.* 2019, 52, 5:1–5:38..

# Study the influence of Laser Energy on the Surface Morphology of Zinc Nano-particle Prepared by Pulsed Laser extirpation Method in Liquid

<sup>[1]</sup> Abbas M. Ali Al-Kifaie, <sup>[2]</sup> Fares A. Yasseen, <sup>[3]</sup> Nariman Neamah Hussein, <sup>[4]</sup> Ali Abid Abojassim

<sup>[1][2][3][4]</sup> Department of physics, Faculty of Science, University of Kufa, Iraq  
E-mail: <sup>[1]</sup> ali.alhameedawi@uokufa.edu.iq

**Abstract**— In this study, we studied the influence of laser energy on the surface morphology of Zinc nanoparticle prepared by pulsed Laser extirpation method in liquid. Prepared by pulsed (Q-switched, Nd: YAG)1064 nm by apply energy of (700 and 800) mJ and frequency of 5 Hz and 300 laser pulses at 25 °C. A laser ablation metal plate is immersed in deionized water. This indicates that the increase of laser energy leads to change of the nanoparticles density and number.

**Keywords**— Pulsed laser extirpation, Zinc Colloidal nanoparticles, FESEM

## I. INTRODUCTION

Generally, Nano-materials are the build-in materials for the twenty-first century and its basic building blocks and the most important pillar of the technologies (nano-technology, bio-technology, information and communication technology)[1,2], which are a standard for the development and civilization of nations and an indication of their rise. The nano-materials vary according to the source, as they differ accordance to their proportions, for example being organic, inorganic materials, natural or preparation materials. All known engineering materials such as metallic elements and their alloys (Metal and Metal Alloys), Metals, Oxides and Semiconductors, as well as in this century reinforce performance in a unique and unprecedented way [3,4]. Nano materials are characterized into a set of materials (crystalline or non-crystalline) of natural or inorganic materials for sizes in the range of 1-100nm[5,6].

Zinc is brittle by nature and a good conductor but exhibits good malleability and ductility at higher temperatures. An electron configuration of the outermost shell of the atom is 4 S<sup>2</sup>. Its constant and only additional oxidation state is +2 [7,8], such other metals of the platinum set is a transition metal and forms complex compounds, in which it acts as a complexing agent[9].

## II. EXPERIMENTAL DETAILS

A metal plate of Zinc with high pureness. supplied from (The British Drug Houses Ltd laboratory Chemical Group) with purity (99.88%). The Zn plate had a smooth surface and was first cleaned ultrasonically in ethanol and distilled water baths consecutively then rinsed with water for (15)min before the experiment to remove all contaminants. Zinc colloidal nano-particles were synthesized by pulse Laser extirpation in liquid (PLAL) technique using Q-switched Nd: YAG laser. The concentrate energy has (700 and 800)MJ, the laser wavelength is (1064) nm and the number of applied pulses (150)pulses, Figure(1) illustrate

the schematic diagram of ablated nanoparticles by PLAL technique. The target of high purity (Zinc) plate was placed on the bottom of open Pyrex container contain (3)ml of ultrapure deionized water and therefore the distance among the target and laser source is (12)cm at the room.

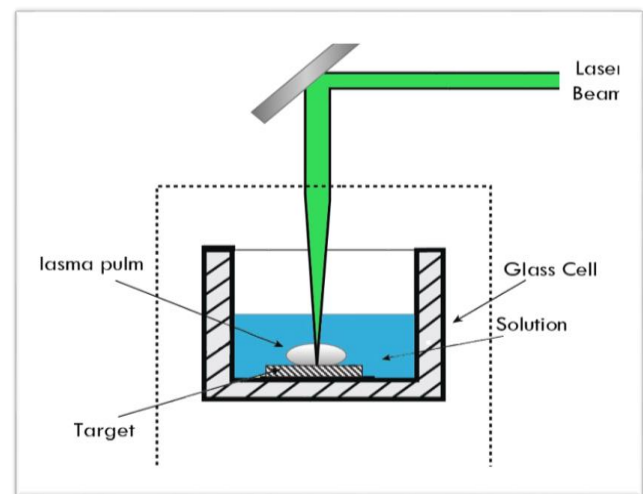

**Figure(1): Laser Ablation System.**

FESEM (FEI FESEM Nano SEM Nova 450) is normally carried out to mensuration the surface morphology of the pattern. The FESEM system employed for this study can produce other characterization work like energy dispersive (EDX) analysis.

## III. RESULTS AND DISCUSSION

Figure(2) and (3) show FESEM of zinc nano-particles produced by laser extirpation in deionized water. The surface morphology of laser extirpation prepared Zinc nanoparticle is very helpful to study the growth mechanism, shape and size of the grains by FESEM technique, Figures(2) shows FESEM micrographs of Zn nanoparticles, wherein it is revealed that the entire surface of the Si substrate is covered uniformly by nanocluster. The



Study the influence of Laser Energy on the Surface Morphology of Zinc Nano-particle Prepared by Pulsed Laser  
Extirpation Method in Liquid

nanoclusters are completely grown and have a their diameters was around (48.6 – 97.7)nm and they were oriented in random directions, as including irregular shape, and dense uniform and unhomogenous surface in sample.

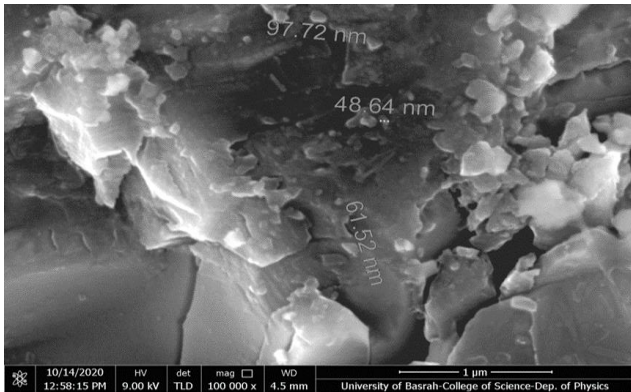

**Figure(2): FESEM images of Zn nanoparticles with scale of (1) µm in (700)MJ.**

Figures(3) shows FESEM micrographs of Zn nanoparticles, wherein it is revealed that the entire surface of the Si substrate is covered uniformly by nanoparticles. The nanoparticles are completely grown and have a their diameters was around (38.15 –75.73)nm and they were oriented in random directions, as including irregular shape, and dense uniform and un homogenous surface in sample

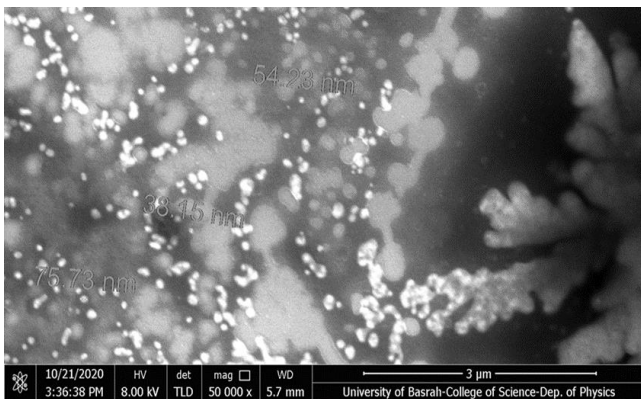

**Figure(3): FESEM images of Zn nanoparticles with scale of (3)µm in (800)MJ.**

**IV. .CONCLUSIONS**

Laser extirpation method is fast, clean, with an extended period of stability, and cheap. It is a better method to provide metallic oxide and metallic nanoparticles within solution. we noted when energy increase, nanoparticles diameters decrease.

**V. ACKNOWLEDGMENTS**

First of all praise be thanks to Allah, the almighty God, the most merciful and the most merciful, who gave me with capability to full this research work. I would like to express my gratitude and appreciation to the all staff in the

Department of Physics, Faculty of Science, University of Kufa.

**REFERENCES**

- [1] Iqbal .T, Tufail. S and Ghazal. S. (2017). Synthesis of Silver ,Chromium, Manganese, Tin and Iron NanoParticles by Different Techniques. Department of Physics, Faculty of Science, University of Gujrat, Vol.13, p.p.19-52.
- [2] Cao .G . (2004). Nanostructure and Nano materials Synthesis, Properties, and Applications. By Imperial College Press.
- [3] Alagarasi .A. (2011). Introduction To Nano materials. Research Institution: Helmholtz Zentrum Muenchen Nanotechnology. Vol. 6, p.p.175–178.
- [4] Thareja. R.K, Shukla.S. (2007 ), Synthesis and characterization of zinc oxide nanoparticles by laser ablation of zinc in liquid, Applied surface science, vol. 253, 8889-8895.
- [5] Swarnkar .R.K, Gopal .R and Singh.S.C .(2010 ) , Zn/ZnO core/shell nano-particles synthesized by laser ablation in aqueous environment: Optical and structural characterizations, Bulletin of Materials Science, vol 33, p.p.21–26.
- [6] Al-Kifaie.A.M, Neamah.N. (2020 ), OPTICAL PROPERTIES OF ZINC NANOPARTICLE PREPARED BY LASER ABLATION IN LIQUID TECHNIQUE, Journal of Critical Reviews. Vol. 7.
- [7] Farahani.S.V, Mahmoodi.A, Goranneviss.M. (2016 ) , The effect of laser en- vironment, on the characteristics of ZnO nanoparticles by laser ablation, International Nano Letters, vol. 6, 45–49.
- [8] Bridgman.P.W. (1925 ), Certain Physical Properties of Single Crystals of Tungsten, Antimony, Bismuth, Tellurium, Cadmium, Zinc, and Tin Proceedings of the American Academy of Arts and Sciences ,Vol. 60, 305-383.
- [9] Support@ mel science.com chemical and physical properties of Zinc.

# The Moderating Role of Intellectual Capital on the Long-Run nexus of Information Security Breaches and Firms' Market Value: A Conceptual Framework

<sup>[1]</sup> Syed Emad Azhar Ali, <sup>[2]</sup> Fong-Woon Lai, <sup>[3]</sup> Muhammad Kashif Shad, <sup>[4]</sup> Rao Faizan Ali, <sup>[5]</sup> Kashif Ali

<sup>[1][2][3][5]</sup> Department of Management & Humanities, Univeristi Teknologi PETRONAS, Seri Iskandar, Perak, Malaysia

<sup>[4]</sup> Department of Management & Humanities, Univeristi Teknologi PETRONAS, Seri Iskandar, Perak, Malaysia

Email: <sup>[1]</sup> emadazhar2018@gmail.com; <sup>[2]</sup> laifongwoon@utp.edu.my; <sup>[3]</sup> mkashifshad@gmail.com;

<sup>[4]</sup> rao\_16001107@utp.edu.my; <sup>[5]</sup> kashifali009@gmail.com

**Abstract**— Incidents of information security (ISec) breaches are on the rise and pose a potential threat to businesses. Especially for publicly traded firms, they could create a long-lasting influence on their financial performance and market value (MV). Despite its significance, previous studies have examined only the short-run effect on their MVs ensuing to ISec breach announcements. This study aims to conceptualize the long-run effect of ISec breaches on the MV of breached firms by using a one-by-one matched sampling methodology. Alongside today's knowledge economy, investors are always looking for an adequate level of knowledge handling by firms before making investment decisions in uncertain times. Accordingly, a knowledge management indicator demonstrated by 'value intellectual capital efficiency' (VAIC<sup>TM</sup>) has been proposed in this research to indicate ISec risk management and resiliency by firms. Therefore, this research's secondary objective is to conceptualize the moderating effect of VAIC<sup>TM</sup> in the causal relationship between ISec breach announcement and long-run MV of breached firms. We conceptualize how the firm's efficiency in intellectual capital, which embraces human capital efficiency (HCE), structural capital efficiency (SCE), and capital employed efficiency, moderate such effect. The study is expected to be a significant aid for investors, managers, and researchers to understand better the long-run interconnection between security breaches and firms' market value. Also, a sophisticated insight is expected to be provided to managers by which they can develop and disclose their firms' intellectual capital to investors to portray efficient cyber-risk management and resiliency practices.

**Keywords**— Intellectual capital efficiency, knowledge management, long-run abnormal returns, one-to-one matched sampling

## I. INTRODUCTION

As with the evolution of the Internet of Things (IoT) and IR4.0, many rejoice the progressively connected world. However, others have shown severe concerns with the enormous risks that exist concerning loss or theft of data from the dark side of the cyber world. The higher dependency of Internet communication and technology (ICT) is making the business operations more vulnerable for incidents of cyberattacks or information security (ISec) breaches such as spyware, malware, Denial of Service (DOS) attacks, phishing, ransomware, and other vulnerabilities [1-3]. According to a global survey report by Ponemon [4], the number of security breaches suffered by firms has increased gradually from an average of 130 breaches in 2017 to 145 breaches in 2019.

### A. Effect on Firms' Market Value

A firm that suffers an ISec breach will have to bear the tangible and intangible costs after such an event [1, 5, 6]. Tangible costs are the costs for labor, material, and services that are incurred in fixing the damage to information assets and failure to earn extra profits. In comparison, intangible costs incorporate the loss of trust and confidence of business stakeholders which might affect the market value

(MV) of such breached firms. Measuring such an effect on firms' MV is a challenging task. Therefore, various studies have measured the loss in MV using theory for Efficient Markets [5, 7-13]. In most of these studies, the negative effect was witnessed on firms' MV manifested by unfavorable abnormal returns. These studies were underpinned by the semi-strong Efficient Market Hypothesis (EMH) [14, 15], according to which stock prices adjust quickly to all new information. Accordingly, the short-run examination of ISec breach event has been performed in these studies by analyzing the stock price behavior (i.e. from few days before an event to few days after an event) exhibiting an immediate analysis of firms' MV. While the short-run analysis is helpful to get the market's quick reaction to an event announcement, it is imperative to explore the long-run analysis to estimate a more realistic economic effect of a breach announcement. Studies addressing this problem are unclear whether an event of ISec breach will affect MV of firms in long-run.

#### 1. The Long-Run Effect

According to the Global Cost of Data Breach Report [4], the time to identify and contain a data breach has been continuously increasing from 257 days in 2017 to 280 days in 2020, with estimated response cost ranging around \$1

million for each firm. The announcements such as ISec breaches are those where the firms are reluctant to disclose complete details of a breach on their first announcement. In recent times, we have witnessed events of ISec breaches where the details concerning a breach are disclosed months after the first breach announcement. For instance, in July 2019, Equifax was penalized with US\$ 700 million by the Federal Trade Commission (FTC) and Consumer Financial Protection Bureau, ensuing an enormous data breach in 2017. From the investors' perspective, they will probably have a close watch on subsequent disclosures and announcements by the firm concerning an ISec breach announcement that can influence their investment decision making. Hence, the effect on the effect of an ISec event, especially concerning firms' MV, cannot be judged by analyzing the announcement effect only. Especially in cases where the announcement and economic effect vary.

### **B. The Role of Knowledge Management**

Accordingly, companies and researchers are continually trying to develop measures countering cyber-risk to uplift the overall firms' MV in firms' ISec systems and to mitigate the loss in firms' MV ensuing to a cyber-security breach. However, most of those measures are non-financial, thus, providing insufficient estimations to investors regarding the firm's cyber-risk management efficiency. Nevertheless, the phenomenal growth of science and technology in few countries like the United States (US) has given rise to knowledge economies [16]. It implies that investors are always hunting for "good-knowledge-handling" metrics to determine whether their investment would be sound judgment, especially during the event of ISec breach. One still insufficiently covered research issue amid the knowledge economy is exploring intellectual capital as a financial indicator of efficient cyber-risk management. Few studies have advocated that effective knowledge management will not only result in efficient intellectual capital but also give rise to improved cyber-risk management strategies [17-19]. The body of knowledge, however, accompanied by sound analytical findings, is still relatively scarce in the context of the stock market and especially after an event of a cyber-security breach.

Researchers have investigated various ways on how knowledge enhances risk management techniques which in turn helps in the elimination of risks. For any organization, knowledge risk management acts as a competitive advantage because its ability to manage risks stems from the ability to manage knowledge. A recent research area is how to use knowledge management processes to enhance the implementation of risk management processes. It introduces a new field that is not much discussed in the literature in terms of intellectual capital.

Therefore, the primary motivation of this study is to conceptualize the long-run effect on firms' MV after an announcement of an ISec breach. Accordingly, the secondary motivation is to conceptualize the moderating

effect of intellectual capital and its component on the causal relationship between ISec breach and firms' MV. Specifically, more focus is given on a firm's knowledge characteristics, as implied in the firms' intellectual capital efficiency (ICE). In order to measure the level of ICE, and its components which include Structural Capital Efficiency (SCE), Human Capital Efficiency (HCE) and Capital Employed Efficiency (CEE), we propose to apply the coefficient of value-added intellectual capital (VAIC<sup>TM</sup>) indicator developed by [20-24]. We argue that the firm's knowledge characteristics demonstrated by ICE determine the firm performance and its market value. We propose that an ICE would help a firm to recover any loss in market value ensuing to an ISec breach.

In the light of the alarming rise of ISec breach incidents in knowledge economies, announcements of ISec Breach can have a long term negative influence on the market value of the breached firm. Furthermore, the absence of efficient intellectual capital that leads to effective cyber-risk mitigation practices amidst ISec breach announcement would compound the loss in firms' market value. Accordingly, the current paper has raised the following research questions.

*RQ1: What is the long term effect of ISec breach announcement on the market value of breached firms?*

*RQ2: Does the Intellectual Capital Efficiency (ICE) mitigate the effect of ISec breach announcement on the long-run market value of the breached firms?*

## **II. LITERATURE REVIEW AND HYPOTHESIS DEVELOPMENT**

An influential research group has discussed various issues relating to the management of ISec risks, such as ISec investments [25, 26], institutional stimulus on innovation, and security [27]. Another line of research focuses on the market implications of disclosures linked to the security of information [28, 29] and ISec breaches [10, 28-34] by using the event study methodology. The event study methodology has been well established in the field of finance, management and accounts. With this approach, a firms' MV is assessed statistically by tracking and evaluating significant changes to MVs in the post-announcement period. Likewise, in information systems (IS) fields, event studies are now a proven instrument for studying the market responses to numerous IT-related events, such as IT expansion, electronic commerce ventures, or the creation of a new organizational position as a Chief Information Officer (CIO). As ISec is becoming more critical to organizations, the methodology for event research has also become a useful technique for assessing the effect of security incidents on firm values. Studies have employed this methodology to investigate the effect of ISec breaches on the MV of firms [5, 10, 35-38]. However, most of these systematic research works have based only on the short-run effects of breaches while only anecdotally exploring the long-run implications of ISec breaches. For instance, [39]



investigates the element of insider trading, ensuing to an announcement of ISec breach by employing a 41-day event window, which covers 258 ISec breaches. Even though they have reported a -1.44% stock losses, the time-span used was relatively short for representing the long-run market value of firms.

#### A. Long-Run Effect of ISec Breach Announcements

The review of existing works reveals that the implications of events for the firm's long-run prospects, especially the firms' MV, have become a common concern for researchers. Long-run effects have been mostly explored with the BHAR model, 1 to 3 years after the incident. Within the information management avenue, the BHAR model was used to address the long-run value of the company about the effect of Capability Maturity Model (CMM) [40], Enterprise Resource Planning (ERP), Supply Chain Management (SCM), and Customer Relationship Management (CRM) [41, 42]. As far as we know, the effect of an ISec breach on the company's long-run market value has not yet been researched in the avenue of ISec. This research is the first to investigate the effects of the ISec breach on the firms' MV in the long run. Consequently, it is of great significance to conduct empirical research in this regard.

There is an increasing number of studies showing a slow stock market reaction to new information, a valid reason to study the effect of ISec breaches on stocks in the post-announcement era. ISec breaches can also affect firm financials even after the announcement as consumers and suppliers respond to ISec breaches. Parallel to that, firms are also expected to take remedial measures to resolve ISec breaches. Based on these measures' success, firms might recover from these real losses due to ISec breaches or prevent any of the expected losses. Since these effects must be part of the quantification of the overall economic effect of ISec breaches, stock returns should be measured over extended timelines ensuing to an announcement. Accordingly, there are equal possibilities of positive and negative returns in the post-announcement period. Our first hypothesis is:

**H<sub>1</sub>:** *The announcement of an ISec breach will have a significant effect on the long-run abnormal returns of breached firms.*

As has been the situation with modest expectations, the literature offers no guidance on what the optimal time frame for is evaluating the stock returns of the post-announcement. The literature has time frames ranging from one to five years. The appropriate timeframe to examine is a function of the event being studied and the preference of scholars. After an ISec breach disclosure, we conceptualize to examine buy-and-hold abnormal returns over four successive bi-annuals upon and after the announcement of an ISec breach event (i.e.  $t+1$  to  $t+4$ ) where  $t$  is the announcement day and ( $t+1$ ) is the first bi-annual after an ISec breach. This will identify the adverse effects of ISec

breaches as well as any positive effects due to remedial measures. In general, we propose an analysis of the output of stock prices at every six-month interval starting six months post-announcement through two-year post-announcement.

#### B. Knowledge based theory

Under the umbrella of resource based theory, the knowledge-based theory of the firm considers knowledge as the most strategically significant resource of a firm. Its proponents argue that because knowledge-based resources are usually difficult to imitate and socially complex, heterogeneous knowledge bases and capabilities among firms are the major determinants of sustained competitive advantage and superior corporate performance. This knowledge is embedded and carried through multiple entities including organizational culture and identity, policies, routines, documents, systems, and employees. Originating from the strategic management literature, this perspective builds upon and extends the resource-based view of the firm (RBV) initially promoted by [43] and later expanded by others [44-46].

Although the resource-based view of the firm recognizes the important role of knowledge in firms that achieve a competitive advantage, proponents of the knowledge-based view argue that the resource-based perspective does not go far enough. Specifically, the RBV treats knowledge as a generic resource, rather than having special characteristics. It therefore does not distinguish between different types of knowledge-based capabilities. Information technologies can play an important role in the knowledge-based view of the firm in that information systems can be used to synthesize, enhance, and expedite large-scale intra- and inter-firm knowledge management [47]. According to [48] 'the purpose of knowledge management is to maximize the enterprise's knowledge-related effectiveness and returns from its knowledge assets and renew them constantly. Knowledge management is 'hands on' to understand, focus on and manage systematic, explicit and deliberate knowledge building, renewal and application i.e. to manage effective knowledge processes.' Organizations through processes, training, learning and a sharing culture convert these capabilities into core competencies. These competencies can be nurtured into critical success factors to achieve competitive advantage and contribute towards wealth enhancement of organization. All organizations contain three important resources namely; tangible, intangible and financial, and even though intellectual capital (IC) is intangible but it is an excellent source of generating wealth [49].

#### *Emergence of Intellectual Capital as an Indicator for Efficient Knowledge Management*

In recent years, a lot of study has been conducted to develop and clarify the concept of Intellectual Capital (IC), along with its role in increasing the performance of the



firms. "Any knowledge which can be converted to value" is the commonly quoted definition of Intellectual Capital [50]. The essence of intellectual capital is the value creation that can be interpreted as a complex of intangible property, knowledge, skills, processes, applied experience and technologies used in organizations to ensure a competitive advantage on the market [51]. According to the literature [50, 52-56] intellectual capital consists of three main components: human capital, structural capital and relational capital (Figure 1).

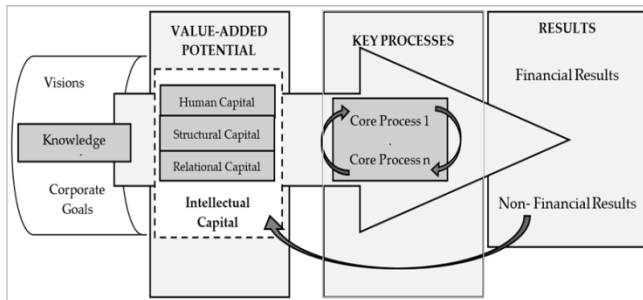

Figure 1: IC component impact mechanism on firm financial performance [57]

Since a long time, especially last decade, a lot of research has been conducted on Intellectual Capital and how it effects the financial performance of any firm. Although some of the results are ambiguous [58, 59], but a positive relation between Intellectual Capital and firms' performance has been verified by a considerable amount of research [60-63]. ARCS model for Intellectual Capital Reporting (presented in Figure 1) illustrates the influence of intellectual capital on the performance of a firm through financial and non-financial results [57].

Intellectual capital is a complex phenomenon, because of which questions related to the effect on the performance of a firm are still not answered. Out of all methods to assess financial information, the most commonly used is by [21]. He proposed that value-added intellectual capital (VAIC<sup>TM</sup>) can be used as an indicator to measure performances in the context of the knowledge economy. His concept of VAIC<sup>TM</sup> has been criticized because of his assumptions [64, 65] along with weak results when considering the relation between VAIC<sup>TM</sup> and firm performance in some industries and emerging markets [66]. According to [59] much criticism is because of misunderstandings since, compared to Scandia Navigator, Pulic has to give different meanings to human capital (HC) and structural capital (SC). They believe that "the bridge that Pulic created between the notions of value-added and that of value creation in a knowledge economy context constitutes the strength of his proposal". On the contrary, it is also believed that VAIC<sup>TM</sup> was not able to qualify as a measuring criterion, when compared with EVA. This is because VAIC<sup>TM</sup> complements existing measurement of the multidimensional concept of firm performance as an innovative indicator of intellectual capital efficiency (ICE).

The link between organizational performance and intellectual capital is becoming more and more an exciting issue, especially in times of severe economic turbulence, when companies are seeking new solutions in order to survive. Hence one of the options is to put more efforts in improving intellectual capital usage. The qualitative research study by [67] confirmed that organizations use their relational capital to continue operations and negotiate with suppliers, customers and financiers, because of recession causing financial constraints. Similarly, according to various grounding theories, the role of intellectual capital in firms' value creation should have increased as a result of crisis such as ISec breaches. An event of ISec breach will have a tangible and intangible repercussions on the financial health of breached firm. Thereby, triggering uncertainty and risks among the business stakeholders and especially those in stock market. The ability of an organization to manage risks derives from its capacity to manage IC, therefore, its efficient management can help improves risk management techniques and reduces uncertainties at the events of ISec breaches. For instance, [68] advocated that information security knowledge sharing not only increases the level of awareness as an effective approach, but also reduces the cost of information security in organizations.

Unfortunately, based on quantitative analysis, no empirical evidence have been found yet, which can explain the changes in Intellectual Capital in financial performance improvement as a proxy to increase the market value of breached firms. On the basis of this line of research (e.g.,[69-71], we conceptualize some characteristics of firms' IC namely HCE, SCE and CEE can helps the firms to recover from any market value losses in the event of ISec breach announcements.

Considering the discussion above, the following hypotheses can be formulated:

**H<sub>2</sub>:** *The value-added intellectual capital of a firm negatively moderates the relationship between ISec breach announcements and the firm's market value.*

*The sub-hypothesis for H<sub>2</sub> can be derived as follows:*

**H<sub>2A</sub>:** *Human capital efficiency (HCE) of a firm negatively moderates the relationship between ISec breach announcements and the firm's market value.*

**H<sub>2B</sub>:** *Structural capital efficiency (SCE) of a firm negatively moderate the relationship between ISec breach announcements and the firm's market value.*

**H<sub>2C</sub>:** *Capital employed efficiency (CEE) of a firm negatively moderate the relationship between ISec breach announcements and the firm's market value.*

The Moderating Role of Intellectual Capital on the Long-Run nexus of Information Security Breaches and Firms' Market Value: A Conceptual Framework

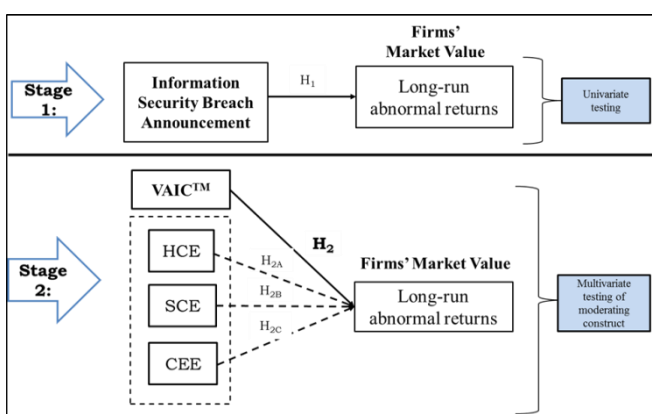

Figure 2: Conceptual framework in two stages

Figure 2 portrays the conceptual framework of this study in two stages. In the first stage, the study proposes the investigation of abnormal changes in MV (endogenous constructs) if any, after an ISec breach announcement (exogenous construct). The market value of a firm is demonstrated by long-run abnormal returns (BHAR). Based on the abnormal results in stage 1, the study conceptualizes the use of VAIC<sup>TM</sup> as a moderator construct in stage two of the framework. As advocated by [20, 23, 24, 72], VAIC<sup>TM</sup> is measured by factors of human capital efficiency (HCE), structural capital efficiency (SCE) and capital employed efficiency (CEE).

### III. METHODOLOGY

The methods and estimation techniques we have proposed in measuring the long-run abnormal returns are different from those usually used in event studies when the short-run effect of events is analyzed on the stock market. As the methodology of event study frequently provides skewed approximations of both the ultimate economic influence and the test statistics [73, 74]. Our findings are based on robust and more accurate methods, which were newly established and used frequently in studies [42, 75-78].

#### A. Sample Selection

The sample data of firms suffering from ISec breaches can be extracted from online sources of data such as 'The Privacy Rights Clearing House' (PRCH), Identity Theft Resource Centre (ITRC), and Carnage. All ISec breach announcements by a firm should qualify the following in order to remain in our sample:

1. The firm is publicly listed in any of the stock exchange in US (i.e., New York Stock Exchange (NYSE) or the National Association of Securities Dealers Automated Quotations (NASDAQ)).
2. The firms must have returned information on the Center for Research on Security Prices (CRSP) database.
  2. The firm must trade on at least 80 percent of their trading days within one year before the ISec breach announcement.

3. The firm did not report any other ISec breach within 18 months of this date of notification.
4. When the breach occurred on an unlisted subsidiary firm, the parent company was tracked.
5. The firm must have a book value greater than zero.

#### B. Assessing the Long-Run Abnormal Returns

The fundamental issue in long-run stock market studies is to forecast abnormal returns for the concerned firms which are included in our sample. Abnormal returns are hypothesized. An abnormal return is a gap between a stock return and a comparable benchmark return as equivalent to zero over the concerned era in which the benchmark is employed in controlling variables to support stock returns. The notion is that whatever appears unknown after controlling for the identified variables is found abnormal and can be linked to the event being addressed. Anything which remains unexplained is known to be abnormal and can be related to the event.

The literature argues as to how to measure long-run abnormal returns [73, 79]. The first problem is the relevant variables to be controlled for calculating abnormal long-run returns. Previous studies on long-run stock valuation have been primarily controlled for a company's systemic risk (or beta). According to current research, the size, market-to-book ratio, and previous performance are imperative predictors of stock returns [80-82]. The present consensus, therefore, appears to be that abnormal returns have to be determined after controlling size, market-to-book ratio, and previous performance [75].

The second question is to grasp the statistical significance of abnormal long-run returns. Studies by [73, 74] noted that the test statistics of many widely employed approaches are highly flawed, making it challenging to comprehend the real significance of abnormal returns reported. The principal cause of the measurement error is the cross-sectional correlation that exists due to overlaid periods between sampled firms, which occurs typically in long-run stock price examinations. Cross-sectional correlation leads to bias test statistics (positive or negative). Recent regression findings indicate that abnormal returns by one-to-one match sampling methodology [73, 75] provide well-defined tests.

#### Buy-and-Hold Abnormal Returns (BHARs) using One-to-One Match Samples

Our proposed approach is one-to-one matching in which each sample firm is compared to the appropriate control firm having similar size, market-to-book ratio, and prior performance. Then it is recommended to create two individual samples of one-to-one:

1. Choose a firm nearest in size to the sample firm from the allocated portfolio of the sample firm (size-matched).

- Choose a firm nearest to the sample firm in terms of its previous performance from the allocated portfolio of the sample firm (performance-matched).

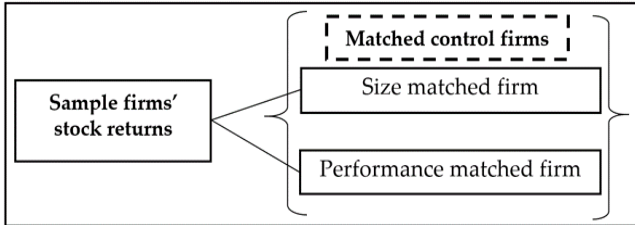

**Figure 2: One-to-One Matched Sampling Methodology to Detect Abnormal Returns [73]**

The methodology of one-to-one-matched-sampling has been further illustrated in **Figure 3**. This paper provides an estimate of (BHARs) by daily return statistics as advocated by [73, 75]. BHAR calculation, therefore, requires that the sample firm's and its matched control firm's raw returns be initially compounded over time. Mathematically,

$$BHAR_i = \prod_{t=1}^T (1 + R_{it}) - \prod_{t=1}^T (1 + R_{mct}) \quad (1)$$

Where,  $BHAR_i$  is the buy-and-hold abnormal return for stock  $i$ ,  $R_{it}$  is the rate of return for stock  $i$  on day  $t$ ,  $R_{mct}$  is the rate of return for the matched control firm for stock on day  $t$ , and  $T$  is the number of days in the period of interest. By summing the abnormal returns of all event samples, divided by the number of event samples ( $N$ ), the average buy-and-hold abnormal returns are calculated using the following expression.

$$\overline{BHAR}_{it} = \frac{1}{N} \sum_{i=1}^N BHAR_i \quad (2)$$

with the updated version of the standard t-test, the statistical value was assessed for results obtained using the  $BHAR$  process. The measurement formula developed by [83] was employed here:

$$t = \frac{\overline{BHAR}_{it}}{\sqrt{\frac{\sigma_i^2}{N} + \frac{\sigma_{mc}^2}{N}}} \quad (3)$$

Where,  $\sigma_i^2$  is the variance of firm  $i$  and  $\sigma_{mc}^2$  is the variance of the matched control firm.

### C. Mapping of ISec Events for Assessment of the Market Value

In order to collect findings over time, we conceptualize to map the calendar to date of the occurrence for each entity in our sample. The day of the announcement is day 0 termed as 't' for this research. In line with the objective of this paper, we propose to analyze BHAR from one bi-annual before announcement 't-1' to four bi-annual after the announcement date (i.e. from t-1 to t+1, t-1 to t+2, t-1 to t+3, t-1 to t+4). The bi-annual before the announcement (t-1) will serve as the base bi-annual because it is appropriate and exempted from the effect of the breach announcement.

Since each year consists of around 250 trading days each year, it is contemplated to deduct from both sides of the event day 't' a 2-week duration (10 trading days) while measuring abnormal changes in stock returns. It is advised to ensure that our assessments on market value cannot be unduly influenced by the unexpected trading practices which may occur around the date of the announcement. That is expected to give a more exact picture of firms' market value in the long-run. It is fair to expect that there will be immediate changes in market value ensuing to notification of ISec breaches. We degree buy-and-hold abnormal returns over the four periods, as shown in **Table 1**. We also suggest that the parametric t-test be used to evaluate the mean abnormal performance and the non-parametric Wilcoxon signed-rank (WSR) test to review the median abnormal performance. Using the WSR test to complement the t-test means that outliers do not excessively bias our results. In order to examine post-event abnormal performance of sample firms (i.e., t-1 to t+4), it is essential to test if there is any pre-event bias in BHAR (i.e. from t-2 to t-1). There should not be any abnormal performance in the period preceding t-1.

**Table 1: Time mapping for estimation for BHAR**

Term	Time period	Days
Bi-annual before announcement to 1 <sup>st</sup> bi-annual after announcement	t-1 to t+1	-135 to +135 days
Bi-annual before announcement to 2 <sup>nd</sup> bi-annual after announcement	t-1 to t+2	-135 to +260 days
Bi-annual before announcement to 3 <sup>rd</sup> bi-annual after announcement	t-1 to t+3	-135 to +385 days
Bi-annual before announcement to 4 <sup>th</sup> bi-annual after announcement	t-1 to t+4	-135 to +510days

### Methodology for Measuring the VAIC<sup>TM</sup>

VAIC<sup>TM</sup> indicator, developed by Pulic, is a tool which we propose to measure the level of intellectual capital in the firm [20, 23, 24, 72]. Following [72], the sum of Capital Employed Coefficient (CEE) and Intellectual Capital Efficiency Coefficient (ICE) yields the composite. The first coefficient (ICE) is a combination of indicator of human capital efficiency (HCE) and structural capital efficiency (SCE). HCE shows the amount of value addition (V.A.), (the difference between the total output and input representing the new wealth created) created by the human capital (H.C.) and the total labor costs which describe the investment in knowledge workers). The calculation is HCE=VA/HC. SCE, on the other hand, measures the share of structural capital (here human capital and structural capital are inversely proportional, SC=VA-HC) in the creation of value-added. The calculation is SCE=SC/VA. The value of ICE is therefore given by summing up. The



latter coefficient (CEE) acts as an asset value efficiency indicator and represents the value (V.A.) provided by one unit of a company's physical and financial resources (C.E.). The calculation formula looks as follows:  $CEE=VA/CE$ . We present the visualization of entire VAIC<sup>TM</sup> formula in **Figure 4**.

We propose Hierarchical Linear Modeling (HLM) to examine the relationship between intellectual capital and its components (as measured by the VAIC<sup>TM</sup> model) and firm performance. HLM is commonly used to analyze multilevel data [84, 85] because it overcomes the statistical shortcomings of conventional nested data analysis. After that, the moderation variables at firm-level will be used in the base model one by one. In order to measure VAIC<sup>TM</sup> of each sample of a firm, we suggest taking the average of its VAIC<sup>TM</sup> in the two years preceding the breach announcement.

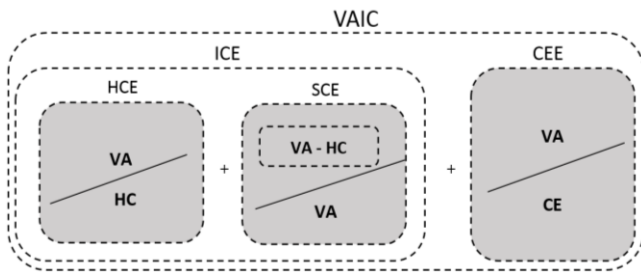

**Figure 4: VAIC<sup>TM</sup> formula visualization**

Mathematically, the next step is to develop and test multiple regression models in order to identify the influence that VAIC and its three components have on the market value of companies as manifested by buy-and-hold-abnormal-returns. The regression function to be tested at every bi-annual has been exhibited in **Table 2**. Where time represents the four bi-annual periods on which the BHAR to be tested, that is  $(t-1, t+1)$ ,  $(t-1, t+2)$ ,  $(t-1, t+3)$  and  $(t-1, t+4)$ .

**Table 2: Regression models to be analyzed**

Dependent Variable	Regression Models
BHAR <sub>time</sub>	$= \alpha_0 + \alpha_{1time} VAIC_{t-1}$
BHAR <sub>time</sub>	$= \alpha_0 + \alpha_1 VAIC_{t-1} + \alpha_2 \text{control variables}$
BHAR <sub>time</sub>	$= \alpha_0 + \alpha_1 HCE_{t-1} + \alpha_2 \text{control variables}$
BHAR <sub>time</sub>	$= \alpha_0 + \alpha_1 HCE_{t-1} + \alpha_2 SCE_{t-1} + \alpha_3 \text{control variables}$
BHAR <sub>time</sub>	$= \alpha_0 + \alpha_1 HCE_{t-1} + \alpha_2 SCE_{t-1} + \alpha_3 CEE_{t-1} + \alpha_4 \text{control variables}$

**IV. SUMMARY AND IMPLICATIONS**

Incidents of ISec breaches can have a long-run effect on the performance of effected firms. Despite, its growing significance, there are few studies providing an understanding for such long-run effect. Using the same underpinning of EMH theory, we have conceptualized in

this study that, incidents of ISec breach can have a long-run effect on the MV of breached firms. Alongside, firms are exploring new ways to counter the eminent threat of ISec breaches and to mitigate the unfavorable effect on performance and its MV after an event of ISec breach. The growth of ICT has given birth to knowledge economies, where investors are always searching for good level of knowledge handling and risk management by firms. For knowledge economies like US, we have proposed to use VAIC<sup>TM</sup> as an indicator of efficient knowledge management and ISec risk management. We have conceptualized that, firms with efficient IC (i.e. with higher VAIC<sup>TM</sup>) will bear a lower MV losses after ISec breach announcement. Such a tool for measuring the firms' ISec risk management has not been established in previous studies. Evidence shows that firms in the financial sector are most vulnerable to incidents of ISec breaches and the investors are most sensitive to ISec breaches in such cases. Outcomes of this study will provide policy insights to the practitioners and policymakers to achieve higher business sustainability by minimizing the MV losses through efficient estimations. By emphasizing on the IC management, our study will eventually help the businesses in financial sector to streamline the digitization process which will holistically contribute towards the stability of the global financial system. Hence, the completion of this study has some serious implications, few of them are described in next section.

**A. Theoretical Implications**

This paper conceptualizes at the effect of ISec breaches on long-run MV as shown by buy-and-hold abnormal-returns on the stock. In the area of ISec, several studies have examined the effect of events on the short-run MV, based on short-run abnormal returns. Whereas few [86] have investigated the effect on MV in such events. However, for a few reasons, we believe that the long-run abnormal returns, as proposed in the current study, are more compelling and reliable. First, a more robust methodology of one-to-one-matched sampling is proposed for long-run analysis. The former computed the abnormal returns through event study methodology in which the sample firms' returns were matched with a benchmark of a market index. There has been an influential research group that advocates that size and market-to-book ratio [81] and prior performance [80, 82] are significant estimators of stock returns. So, the sample firms' returns should be matched with similar firms having similar size and performance. Our study has followed the same consensus that abnormal returns should be estimated after controlling for size, market-to-book ratio, and prior performance [75]. Second, the statistical significance of the long-run abnormal returns observed is difficult to interpret. Reference [73, 74] report on the severely mis specified testing statistics from many widely used methods, making it difficult to assess the real significance of observed abnormal returns. The existence of cross-sectional dependence resulting from the overlap



between sampling firms seen in long-term stock price studies is a primary cause of misspecification. Cross-sectional (positive or negative) dependence contributes to testing statistics that are skewed. The literature's simulation results indicate that abnormal returns determined using one-to-one matching provide well-specified tests [73, 75]. For these reasons, we can claim that the proposed method in this study is more robust than those proposed and examined in previous research.

Technology management researchers are keen towards knowledge-based competition and to know how firms preserve their value, especially in times of crisis. Previous research on KBV has shown that, as an intangible resource, a firms' knowledge confers significant competitive advantages [87]. However, little is known about how the knowledge base indicator, such as the intellectual capital, influence the market value of the firm. The current study EMH claims to add the body of knowledge by integrating theories of efficient market and knowledge based. It is conceptualized that stock market's reaction after unfavorable ISec event will also be a function of knowledge characteristics which is demonstrated by the firms' ICE.

We proposes that some knowledge attributes of IC such HCE, CEE and SCE can help preserve MV of a firm at the event of ISec breach. Firms certainly need innovative ideas to prevent themselves from ISec breaches and the subsequent loss in their MVs. However, the questions of whether or not, and under what circumstances, such knowledge-based advantages are sustained are equally important to address [69, 70]. We contribute to theory by conceptualizing that what matters is not only whether firms have higher level of IC, but more importantly the types of firms' IC characteristics that moderate the negative effect on firms' MV ensuing to an ISec breach. Previous research asserts that the competitive advantage of a firm is achieved through accumulated, [68] idiosyncratic, and imperfectly mobile knowledge (e.g., Verona, 1999). Our proposal to use firms' knowledge characteristics (i.e. IC) as moderating factors allows us to provide a better and direct insight towards providing sustained advantages to a business. This paper will contribute also to the literature of knowledge management by aligning knowledge resources and capabilities with intellectual requirements in an ISec risk management framework.

### ***B. Practical Implications***

Our conceptualization of the long-run MV ha obvious implications for managers and policy makers. The estimates based on long skylines are more of value to investors and managers as it furnishes them with a progressively wide-ranging image of the financial ramifications of ISec breaches. By investigating the long-run effect of ISec breaches, we can reveal insight into the timeline of abnormal stock price performance as far as when it begins, to what extent it keeps going, and whether firms recuperate ISec breaches rapidly. These issues are significant in setting

practical anticipations concerning possible ramifications of ISec breaches.

Second, we proposes that some IC characteristics might have greater moderating effect then others on firms' MV, and this could depend on the IC characteristics of a firm, not simply on the ISec breach itself. Our conceptual framework can help firms for competitive advantage, parting both from the essence of human, structural and capital employed, as well as from the challenge of assimilating IC management in ISec risk mitigation processes. We recommend managers or policy makers to focus more on increasing their company intellectual capital performance, with specific focus on intellectual capital component that is a key driver of value creation in their industry. The relationship between intellectual capital, its components and firm financial performance leading to firms' MV creation appears to have gained on importance after the growing incidents of ISec breaches. Therefore, we argue that intellectual capital has become more and more important driver of firm MV creation.

### ***C. Limitations of the Study and Future Research Directions***

In this study, there are certain limitations and future research needs. Despite proposing to analyze sample firms' performance through a one-to-one matching approach, there could still be an endogeneity problem. The matching portfolio approach can further improve future research reliability for forecasting firms' MV ensuing to an ISec breach.

Another limitation is about the availability of enough data to perform statistical analysis. Unlike, U.S., firms in most of the countries are not bound by their regulators to announce incidents of ISec breaches. As of right now, the analysis can be performed which are either headquartered in U.S. or their stocks are listed in US stock exchanges such as NYSE, NASDAQ or AMEX. However, with the availability of data due to growing reporting requirements in other countries, it is expected that the analysis can be performed for other countries as well [88].

Future studies can perform an examination of relationship between performance of intellectual capital or its components and firm financial performance before and after an ISec breach announcement. As a part of this research stream, we suggest paying attention to investigation how mean values of intellectual capital performance measurement constructs (VAIC<sup>TM</sup> and its components HCE, SCE and CEE) in different industries have changed during the times of growing ISec breaches.

From past studies, it has been concluded that financial sector has been the biggest victim of ISec breaches as they suffer in short and long-run subsequent to incidents of ISec breaches [6, 89-91]. Alongside, financial sector is one of the most suitable areas for studying and researching IC

because of the service and intellectual nature of the financial industry, which focuses mainly on knowledge and employee skills, more than financial and physical capital. In addition, this sector is known for its availability of reliable data [92]. It is also believed that using IC in creating value in knowledge-based sectors, such as financial sector, is higher than other economic sectors [93]. Therefore, it will be interesting to examine, how characteristics of IC play their role in mitigating the consequences on breached firms' financial performance, especially the effect on MV.

Studies in future can also examine the moderating effect of IC for favorable events of ISec. That is, when the firms announce or acquire an ISec investment, ISec certification or ISec development. It will be interesting to witness, how, characteristics of IC can positively moderate the effect of favorable ISec event on the MV of firms. The findings would encourage the managers and policy makers to invest in IC management.

### Acknowledgment

This work was supported and funded by the Department of Management & Humanities-Universiti Teknologi PETRONAS (UTP) and Faculty of Business and Economics-Universitas Islam Indonesia (UII) under grant cost centre: 015MEO-114.

### REFERENCES

- [1] K.T. Smith, A. Jones, L. Johnson, and L.M. Smith, Examination of cybercrime and its effects on corporate stock value, *Journal of Information, Communication and Ethics in Society* 17 (1) (2019) pp. 42-60.
- [2] J. Jansen, M. Junger, L. Montoya, and P. Hartel, *Offenders in a digitized society*, Cybercrime and the Police, (Eleven International Publishing, 2013), pp. 45-59.
- [3] I. Lukonga, *Fintech, inclusive growth and cyber risks: Focus on the MENAP and CCA regions*, IMF Working Papers 18 (2018)
- [4] Ponemon, *Cost of a data breach report*, IBM Security, July, (2020) <https://www.ibm.com/security/digital-assets/cost-data-breach-report/#/>.
- [5] H. Cavusoglu, B. Mishra, and S. Raghunathan, The effect of internet security breach announcements on market value: Capital market reactions for breached firms and internet security developers, *International Journal of Electronic Commerce* 9 (1) (2004) pp. 70-104.
- [6] I. Bose, and A.C.M. Leung, Do phishing alerts impact global corporations? A firm value analysis, *Decision Support Systems* 64 (August) (2014) pp. 67-78.
- [7] M. Ettredge, and V.J. Richardson, *Assessing the risk in e-commerce*, Annual Hawaii International Conference on System Sciences, Hawaii, US, January 10 2002, pp. 1-11.
- [8] K. Campbell, L.A. Gordon, M.P. Loeb, and L. Zhou, The economic cost of publicly announced information security breaches: Empirical evidence from the stock market, *Journal of Computer Security* 11 (3) (2003) pp. 431-448.
- [9] A. Hovav, and J. D'Arcy, The impact of virus attack announcements on the market value of firms, *Information Systems Security* 13 (3) (2004) pp. 32-40.
- [10] K. Kannan, J. Rees, and S. Sridhar, Market reactions to information security breach announcements: An empirical analysis, *International Journal of Electronic Commerce* 12 (1) (2007) pp. 69-91.
- [11] A. Malhotra, and C. Kubowicz Malhotra, Evaluating customer information breaches as service failures: An event study approach, *Journal of Service Research* 14 (1) (2011) pp. 44-59.
- [12] G. Sinanaj, and J. Muntermann, Assessing corporate reputational damage of data breaches: An empirical analysis, 26<sup>th</sup> Bled EConference - EInnovations Challenges and Impacts for Individuals, Organizations and Society, Bled, Slovenia, June 9-13 2013, pp. 78-89.
- [13] S. Tweneboah-Kodua, F. Atsu, and W. Buchanan, Impact of cyberattacks on stock performance: A comparative study, *Information and Computer Security* 26 (5) (2018) pp. 637-652.
- [14] E.F. Fama, L. Fisher, M.C. Jensen, and R. Roll, The adjustment of stock prices to new information, *International Economic Review* 10 (1) (1969) pp. 1-21.
- [15] R.A. Schwartz, Efficient capital markets: A review of theory and empirical work: Discussion, *The Journal of Finance* 25 (2) (1970) pp. 421-423.
- [16] N.F. Ghriss, *Global knowledge index*, United Nations Development Programme and Mohammed Bin Rashid Al Maktoum Knowledge Foundation, December 10, (2020) <https://www.undp.org/content/undp/en/home/librarypage/capacity-building/Global-Knowledge-Index-2020.html>.
- [17] J.K. White: 'Impact of Protection Motivation Theory and General Deterrence Theory on the Behavioral Intention to Implement and Misuse Active Cyber Defense', Capella University, 2017
- [18] S. Wang, and H. Wang, Knowledge Management for Cybersecurity in Business Organizations: A Case Study, *Journal of Computer Information Systems*(2019) pp. 1-8.
- [19] N.S. Safa, R. Von Solms, and S. Furnell, Information security policy compliance model in organizations, *Computers & Security* 56(2016) pp. 70-82.
- [20] A. Pulic, *The principles of intellectual capital efficiency-A brief description*, Croatian Intellectual Capital Center, Zagreb 76(2008)

- [21] A. Pulic, The principles of intellectual capital efficiency-A brief description, (2008) <https://scinapse.io/papers/2371185822>.
- [22] A. Pulic, Intellectual capital—does it create or destroy value?, *Measuring Business Excellence* 8 (1) (2004) pp. 62-68.
- [23] A. Pulic, VAICTM—An accounting tool for IC management, *International Journal of Technology Management* 20 (5-8) (2000) pp. 702-714.
- [24] A. Pulic: 'Measuring the performance of intellectual potential in knowledge economy', in Editor (Ed.)^(Eds.): 'Book Measuring the performance of intellectual potential in knowledge economy' (McMaster University, Hamilton, 1998, edn.), pp. 1-20
- [25] L.A. Gordon, and M.P. Loeb, Budgeting process for information security expenditures, *Communications of the ACM* 49 (1) (2006) pp. 121-125.
- [26] L.A. Gordon, and M.P. Loeb, The economics of information security investment, *ACM Transactions on Information and System Security* 5 (4) (2002) pp. 438-457.
- [27] C. Hsu, J.N. Lee, and D.W. Straub, Institutional influences on information systems security innovations, *Information Systems Research* 23 (3-2) (2012) pp. 918-939.
- [28] T. Wang, K.N. Kannan, and J.R. Ulmer, The association between the disclosure and the realization of information security risk factors, *Information Systems Research* 24 (2) (2013) pp. 201-218.
- [29] L.A. Gordon, M.P. Loeb, and T. Sohail, Market value of voluntary disclosures concerning information security, *MIS Quarterly* 34 (3) (2010) pp. 567-594.
- [30] P.B. Lowry, J. Cao, and A. Everard, Privacy concerns versus desire for interpersonal awareness in driving the use of self-disclosure technologies: The case of instant messaging in two cultures, *Journal of Management Information Systems* 27 (4) (2011) pp. 163-200.
- [31] A. Hovav, and J. D'Arcy, Capital market reaction to defective IT products: The case of computer viruses, *Computers & Security* 24 (August) (2005) pp. 409-424.
- [32] J.K. Deane, D.M. Goldberg, T.R. Rakes, and L.P. Rees, The effect of information security certification announcements on the market value of the firm, *Information Technology and Management* 20 (3) (2019) pp. 107-121.
- [33] J. Goldstein, A. Chernobai, and M. Benaroch, An event study analysis of the economic impact of IT operational risk and its subcategories, *Journal of the Association for Information Systems* 12 (9) (2011) pp. 606-631.
- [34] J. Cao, T. Calderon, A. Chandra, and L. Wang, Analyzing late SEC filings for differential impacts of IS and accounting issues, *International Journal of Accounting Information Systems* 11 (3, September) (2010) pp. 189-207.
- [35] S. Goel, and H.A. Shawky, Estimating the market impact of security breach announcements on firm values, *Information & Management* 46 (7, October) (2009) pp. 404-410.
- [36] A. Hovav, and P. Gray, The ripple effect of an information security breach event: A stakeholder analysis, *Communications of the Association for Information Systems* 34 (February) (2014) pp. 893-912.
- [37] A. Hovav, F.K. Andoh-Baidoo, and G. Dhillon: 'Classification of security breaches and their impact on the market value of firms', in Editor (Ed.)^(Eds.): 'Book Classification of security breaches and their impact on the market value of firms' (2007, edn.), pp.
- [38] R. Telang, and S. Wattal, An empirical analysis of the impact of software vulnerability announcements on firm stock price, *IEEE Transactions on Software Engineering* 33 (8) (2007) pp. 544-557.
- [39] Z. Lin, T.R. Sapp, J.R. Ulmer, and R. Parsa, Insider trading ahead of cyber breach announcements, *Journal of Financial Markets* 50 (September) (2019) pp. 100527-100541.
- [40] G. Filbeck, M. Swinarski, and X. Zhao, Shareholder reaction to firm investments in the capability maturity model: an event study, *European Journal of Information Systems* 22 (2) (2013) pp. 170-190.
- [41] B. Dehning, V.J. Richardson, and R.W. Zmud, The financial performance effects of IT-based supply chain management systems in manufacturing firms, *Journal of Operations Management* 25 (4) (2007) pp. 806-824.
- [42] K.B. Hendricks, V.R. Singhal, and J.K. Stratman, The impact of enterprise systems on corporate performance: A study of ERP, SCM and CRM system implementations, *Journal of Operations Management* 25 (1) (2007) pp. 65-82.
- [43] E. Penrose, and E.T. Penrose: 'The Theory of the Growth of the Firm' (Oxford University Press, 2009, Fourth edn. 2009)
- [44] K.R. Conner, A historical comparison of resource-based theory and five schools of thought within industrial organization economics: Do we have a new theory of the firm?, *Journal of Management* 17 (1) (1991) pp. 121-154.
- [45] J. Barney, M. Wright, and D. Ketchen Jr, The resource based view of the firm, *Journal of Management* 26 (2) (1991) pp. 342-367.
- [46] B. Wernerfelt, A resource-based view of the firm, *Strategic Management Journal* 5 (2) (1984) pp. 171-180.
- [47] M. Alavi, and D.E. Leidner, Knowledge management and knowledge management systems: Conceptual foundations and research issues, *MIS Quarterly* 25 (1) (2001) pp. 107-136.

- 
- [48] K.M. Wiig, Knowledge management: Where did it come from and where will it go?, *Expert Systems with Applications* 13 (1) (1997) pp. 1-14.
- [49] L. Edvinsson, and P. Sullivan, Developing a model for managing intellectual capital, *European Management Journal* 14 (4) (1996) pp. 356-364.
- [50] L. Edvinsson, Developing intellectual capital at Skandia, *Long Range Planning* 30 (3) (1997) pp. 366-373.
- [51] J. Papula, and J. Volna: 'Intellectual capital as value adding element in knowledge management', in Editor (Ed.)^(Eds.): 'Book Intellectual capital as value adding element in knowledge management' (2011, edn.), pp.
- [52] K.E. Sveiby: 'The new organizational wealth: Managing & measuring knowledge-based assets' (Berrett-Koehler Publishers, 1997. 1997)
- [53] T. Stewart: 'Intellectual Capital Nicholas Brealey Publishing', in Editor (Ed.)^(Eds.): 'Book Intellectual Capital Nicholas Brealey Publishing' (London, 1998, edn.), pp.
- [54] N. Bontis: 'World Congress on Intellectual Capital Readings' (Routledge, 2007. 2007)
- [55] J. Mouritsen, P.N. Bukh, H.T. Larsen, and M.R. Johansen, Developing and managing knowledge through intellectual capital statements, *Journal of Intellectual Capital* 3 (1) (2002) pp. 10-29.
- [56] P.O.d. Pablos, Knowledge management projects: state of the art in the Spanish manufacturing industry, *International Journal of Manufacturing Technology and Management* 5 (4) (2003) pp. 297-310.
- [57] G. Koch, K.-H. Leitner, and M. Bornemann: 'Measuring and reporting intangible assets and results in a European Contract Research Organization', in Editor (Ed.)^(Eds.): 'Book Measuring and reporting intangible assets and results in a European Contract Research Organization' (Citeseer, 2000, edn.), pp. 16-17
- [58] S. Javornik, M. Tekavcic, and M. Marc, The efficiency of intellectual capital investments as a potential leading indicator, *International Business & Economics Research Journal (IBER)* 11 (5) (2012) pp. 535-558.
- [59] G. Iazzolino, and D. Laise, Value added intellectual coefficient (VAIC), *Journal of Intellectual Capital*(2013)
- [60] N. Bontis, S. Wu, M.C. Chen, S.J. Cheng, and Y. Hwang, An empirical investigation of the relationship between intellectual capital and firms' market value and financial performance, *Journal of Intellectual Capital* 6 (2) (2005) pp. 159-176.
- [61] M. Clarke, D. Seng, and R.H. Whiting, Intellectual capital and firm performance in Australia, *Journal of Intellectual Capital*(2011)
- [62] M. Alipour, The effect of intellectual capital on firm performance: An investigation of Iran insurance companies, *Measuring Business Excellence* 16 (1) (2012) pp. 53-66.
- [63] A. Mondal, and S.K. Ghosh, Intellectual capital and financial performance of Indian banks, *Journal of Intellectual Capital*(2012)
- [64] D. Zeghal, and A. Maaloul, Analysing value added as an indicator of intellectual capital and its consequences on company performance, *Journal of Intellectual Capital* 11 (1) (2010) pp. 39-60.
- [65] D. Andriessen: 'Making Sense of Intellectual Capital: Designing a Method for the Valuation of Intangibles' (Elsevier Butterworth-Heinemann, 2004. 2004)
- [66] K.H. Chan, Impact of intellectual capital on organisational performance, *The Learning Organization*(2009)
- [67] H. Lennox: 'Intellectual capital in a recessionary period', in Editor (Ed.)^(Eds.): 'Book Intellectual capital in a recessionary period' (Academic Conferences International Limited, 2012, edn.), pp. 246-254
- [68] N.S. Safa, and R. Von Solms, An information security knowledge sharing model in organizations, *Computers in Human Behavior* 57 (April) (2016) pp. 442-451.
- [69] S.K. McEvily, and B. Chakravarthy, The persistence of knowledge-based advantage: An empirical test for product performance and technological knowledge, *Strategic Management Journal* 23 (4) (2002) pp. 285-305.
- [70] R. Nag, and D.A. Gioia, From common to uncommon knowledge: Foundations of firm-specific use of knowledge as a resource, *Academy of Management Journal* 55 (2) (2012) pp. 421-457.
- [71] H. Wang, and W.-R. Chen, Is firm-specific innovation associated with greater value appropriation? The roles of environmental dynamism and technological diversity, *Research Policy* 39 (1) (2010) pp. 141-154.
- [72] A. Pulic, Intellectual capital—does it create or destroy value?, *Measuring business excellence*(2004)
- [73] B.M. Barber, and J.D. Lyon, Detecting long-run abnormal stock returns: The empirical power and specification of test statistics, *Journal of Financial Economics* 43 (3) (1997) pp. 341-372.
- [74] S. Kothari, and J.B. Warner, Measuring long-horizon security price performance, *Journal of Financial Economics* 43 (3) (1997) pp. 301-339.
- [75] J.D. Lyon, B.M. Barber, and C.L. Tsai, Improved methods for tests of long-run abnormal stock returns, *The Journal of Finance* 54 (1) (1999) pp. 165-201.
- [76] I. Lee, and T. Loughran, Performance following convertible bond issuance, *Journal of Corporate Finance* 4 (2) (1998) pp. 185-207.
- [77] K.B. Hendricks, and V.R. Singhal, The effect of demand–supply mismatches on firm risk, *Production and Operations Management* 23 (12) (2014) pp. 2137-2151.
- [78] K.B. Hendricks, and V.R. Singhal, An empirical analysis of the effect of supply chain disruptions on
-



- long-run stock price performance and equity risk of the firm, *Production and Operations Management* 14 (1) (2005) pp. 35-52.
- [79] E.F. Fama, Market efficiency, long-term returns, and behavioral finance, *Journal of Financial Economics* 49 (3) (1998) pp. 283-306.
- [80] M.M. Carhart, On persistence in mutual fund performance, *The Journal of Finance* 52 (1) (1997) pp. 57-82.
- [81] E.F. Fama, and K.R. French, Multifactor explanations of asset pricing anomalies, *The Journal of Finance* 51 (1) (1996) pp. 55-84.
- [82] N. Jegadeesh, and S. Titman, Returns to buying winners and selling losers: Implications for stock market efficiency, *The Journal of Finance* 48 (1) (1993) pp. 65-91.
- [83] A.R. Cowan, and A.M. Sergeant, Interacting biases, non-normal return distributions and the performance of tests for long-horizon event studies, *Journal of Banking & Finance* 25 (4) (2001) pp. 741-765.
- [84] S.W. Raudenbush, and A.S. Bryk: 'Hierarchical linear models: Applications and data analysis methods' (Sage, 2002, 2nd edn. 2002)
- [85] J. Birkinshaw, R. Nobel, and J. Ridderstråle, Knowledge as a contingency variable: Do the characteristics of knowledge predict organization structure?, *Organization Science* 13 (3) (2002) pp. 274-289.
- [86] K.-C. Chang, Y.-K. Gao, and S.-C. Lee, The effect of data theft on a firm's short-term and long-term market value, *Mathematics* 8 (5) (2020) pp. 808.
- [87] C.W. Craighead, G.T.M. Hult, and D.J. Ketchen Jr, The effects of innovation-cost strategy, knowledge, and action in the supply chain on firm performance, *Journal of Operations Management* 27 (5) (2009) pp. 405-421.
- [88] S.E.A. Ali, and S. Khurram, Impact of demographic and health factors on GDP growth of South Asian Countries, *International Journal of Academic Research in Business and Social Sciences* 7 (3) (2017) pp. 2222-6990.
- [89] J.M. Pelletier: 'Effects of data breaches on sector-wide systematic risk in financial, technology, healthcare and services sectors', Thesis submitted to Capella University, 2017
- [90] G. Sinanaj, and H. Zafar, Who wins in a data breach? A comparative study on the intangible costs of data breach incidents, *Pacific Asia Conference on Information Systems (PACIS)*, Chiayi City, Taiwan, June 27- July 1 2016, pp. 60-75.
- [91] S.E.A. Ali, F.-W.L. Lai, and R. Hassan, Socio-Economic factors on sector-wide systematic risk Of information security breaches: Conceptual framework, 9th International Economics and Business Management Conference, Melaka, Malaysia, 30th December 2020, pp. 502-512.
- [92] D.G. Mavridis, The intellectual capital performance of the Japanese banking sector, *Journal of Intellectual Capital* 5 (1) (2004) pp. 92-115.
- [93] M. El-Bannany, A study of determinants of intellectual capital performance in banks: the UK case, *Journal of intellectual capital*(2008)

# Nganjuk.Hitzz: Innovation Of 360° Based Tourism Information System Development Destination In Nganjuk

<sup>[1]</sup> Dian Ahmad Sasmito, <sup>[2]</sup> LaililiaBintiMohamadSofya

<sup>[1]</sup> State University Of Malang, Malang, Indonesia

<sup>[2]</sup> AirlanggaUniversity, Surabaya, Indonesia

## Abstract:-

Era of sustainable development has provided the government to increase foreign exchange earnings from non-oil and gas. Nganjuk Regency is one of the regions in East Java that has tourism potential. Lack of efforts from local governments and tourism managers in the delivery of tourist information, make tourists less aware of the beauty and uniqueness of tourism in Nganjuk Regency. Purpose of this study are (1) Designing a 360o Tourism Web, (2) Describe 360° Tourism Web system services, and (3) Explain the results of the implementation 360° Tourism Web in Nganjuk Regency. This research is a type of research and development that uses the ADDIE model development. Data collection uses observation, documentation, and questionnaires using purposive sampling method and uses descriptive data analysis. Results of the study, after testing using a web browser if the tourism information system based on 360° Tourism Web is successfully stated. Usability test results state that if the range of 4.6 - 4.76 out of a maximum score of 5, respondents feel this tourism information system is interesting, easy to understand, as needed, easy and convenient to use, and feels interested in visiting the tourist destination.

## Keywords:-

Nganjuk.Hitzz, 360°, Tourism

# Application of the King's Philosophy in the Professional Learning Community to Develop Classroom Learning Promotion Network in Schools in Kanchanaburi Province

**Dr. Karanphon Wiwanthamomgkon**

Faculty of Education, Kanchanaburi Rajabhat University Thailand

## **Abstract:-**

The purpose of this research was conducted by research and development using Participatory Action Research (PAR) which applied article was to the King's Philosophy in the professional learning community and the systematic thinking to develop classroom learning promotion network. The purposes of this research article were 1) to study the background of the school and the need of the development, 2) to develop the model, 3) to study result of model utilization, 4) to evaluate and conduct the lessons learned. The target group of the study were from 31 teachers from 6 schools who attended the network development with volunteering. Results indicated that 1) all educational organization realize the important and need of network development, 2) results of the developed model that assessed by experts showed at good level (Mean = 3.82, S.D. = 0.67). Process of networking operation with 3 steps consisted of step 1 is to build the network and set the target, step 2 is to cooperate creative network development, and step 3 is to conduct lessons learned and extend learning network. 3) Result of model utilization showed the cooperation of school directors, teachers, students, and CCF foundation, and it was shown 92.59 percent in collaborative action. 4) Results of evaluate and conduct the lessons learned showed that the use of networking to promote learning management was good level, self-development of teacher was at good level, development of classroom management of teachers was at good level, students showed good level after the development, students have shown learning behavior and knowledge at reasonable level.

## **Keywords:-**

King's Philosophy, Professional Learning Community, Classroom Learning Network

# Business Operation Approach of Small and Medium Enterprise in Pathumthani Province

<sup>[1]</sup>Dr. Pensri Bangbon, <sup>[2]</sup>Dr. Thanakorn Thanathanchuchot, <sup>[3]</sup>Dr.Yannakorn Toprayoon,  
<sup>[4]</sup>Dr. Chantip Chumdermpadejsuk

<sup>[1][2][3][4]</sup>Pacific Institute of Management Science, Pathumthani University, The Association of Researchers of Thailand, Ramkhamhaeng University, Thailand

## Abstract:-

The purposes of this research are to study; 1) The importance level of factors lead to the business operations approach of SMEs 2) The characteristic of SMEs. 3) The relationship between the characteristic of SMEs and the importance level of factors lead to the business operations approach of SMEs. 4) Business operation approach of Small and Medium Enterprise in Pathumthani Province. Research via quantitative methodology. Data were collected from the executive or owner of SMEs in Pathumthani Province, by accidental sampling of 385 respondents of unknown exactly population. The research instrument were questionnaires. The data were then analyzed by computer software packages, statistic treatments were frequency, percentage, means, standard deviation, and ranking, Pearson Correlation, and Multiple Regression at statistical significance level of .05 The results of the research were as follows: 1) Overall the importance level of factors lead to the business operations approach of SMEs in Pathumthani Province were at of a high importance level, raked by CV (Covariant) respectively were: Technology Development and upgrading of firms' technology, Innovation and information technology, Products, Distribution and supply chain, Business Environment, Price, Government promotion, Market promotion. 2) Overall and individual of the characteristic of SMEs in Pathumthani Province were at of a high importance level, raked by CV (Covariant) respectively were Average total turnover per year, .Amount of employees, SMEs business operation.3) There were moderate relationship level between the characteristic of SMEs and the importance level of factors lead to the business operations approach of SMEs in Pathumthani Province. 4) Business operation approach of Small and Medium Enterprises in Pathumthani Province = was 0.783 Government promotion, was 0.775 Innovation, was 0.771 Technology Development and upgrading of firms' technology, was 0.702 Distribution and supply chain, was 0.681 Products, was 0.641 Price, was 0.421 Market promotion. (R square = 0.851).

## Keywords:-

Business operation approach, SMES



# Corrosion Studies Of Carbon Steel Using Inhibitor Of Citrus X Sinensis And Punica Granatum Peel Extract In Phosphoric Acid Medium

<sup>[1]</sup> Dr. C. Stella Packiam, <sup>[2]</sup> D. Rathika

## Abstract:-

Among the available methods of preventing corrosion the use of inhibitors is one of the most effective methods due to the ease of application and cost effectiveness. A significant part of the cost can be minimized by using inhibitors. In industries inhibitors are used in many systems including cooling systems, refinery units, pipeline chemical operation, steam generations, oil and gas production units. The aims of this research are to discover the inhibition efficiency in different concentration of *Citrus x sinensis* and *Punica granatum* peel's extract. To determine the maximum peel's extract concentration as corrosion inhibitor of mild steel in phosphoric acid environment and immersing times.

## Keywords:-

Corrosion, Weight loss method, Natural inhibitor

# Marketing Factors that Affecting the Purchase of Condominium in Bangkok Thailand

<sup>[1]</sup>Dr. Pensri Bangbon, <sup>[2]</sup>Dr. Thanakorn Thanathanchuchot, <sup>[3]</sup>Dr.Yannakorn Toprayoon,  
<sup>[4]</sup>Dr. PhraSuriya Kongkawai

<sup>[1][2][3][4]</sup>Pacific Institute of Management Science, Pathumthani University, The Association of Researchers of Thailand, Mahachulalongkornrajavidyalaya University Nakhon Si Thammarat Campus, Thailand

## Abstract:-

The purposes of this research were to study; 1) Purchasing Behavior of Condominium 2) The importance level of factors affecting the purchasing of condominium in Bangkok Thailand.3) The affected purchased level of condominium in Bangkok Thailand. Research and development methodology by quantitative methodology data were collected from used to purchase condominium in Bangkok via accidental sampling of 385 respondents of unknown exactly population. The research instrument were questionnaires. The data were then analyzed by computer software packages, statistic treatments were frequency, percentage, means, standard deviation, and ranking, Pearson Correlation, and Multiple Regression at statistical significance level of .05.The results of the research were as follows: 1) Overall and individual of customers purchased behavior of condominiums were of a high level, raked by mean respectively were: Person influencing Purchasing condominium, Category of condominium by price, and Purpose of purchasing behavior of condominiums.2) Overall and individual of the importance level of the factors affected the purchased condominium in Bangkok were at of a high importance level, raked by mean respectively were : Condominium Location, Promotion, Price of condominium, Brand Equity, Condominium Sales (place), and Condominium room (Product). 3) The marketing factors affected purchased condominium in Bangkok = was 0.898 condominium location, was 0.721 Promotion, was 0.691 Condominium room (Product), was 0.625 Price of condominium, was 0.572 brand equity, was 0.412 condominium sales (place). (R square = 0.882).

## Keywords:-

Marketing factors, Purchase condominium

# Integration Of ICT In Academic And Administrative Management Processes

<sup>[1]</sup> Edwin Martinez-Alvarez, <sup>[2]</sup> Judith Soledad Yangali Vicente

## Abstract:-

The main purpose of the research was to determine the direct relationship that exists between the integration of ICT with academic management and administrative management in Colombian educational institutions. In the integration of ICT, academic and administrative management are determining factors for the improvement of quality in the learning-teaching process in an educational institution, it is there where the importance of a curriculum design, pedagogical practices and management lies. of classroom directed to the implementation of technological tools where creativity and innovation of students and teachers are promoted, making the school an attractive and attractive setting for education. The investigation was raised from a quantitative approach, as for the method used in the investigation the hypothetical - deductive method was used, to collect the information the survey technique was applied and three questionnaires with a Likert-type scale were developed as instruments. Pearson's correlation coefficient ( $\alpha = 0.05$ ) was used for the data analysis method. The population consisted of 185 teachers of elementary, secondary and middle school from eight educational institutions in the district of Turbo, Colombia. Concluding that there is a significant relationship between the integration of ICT and academic and administrative management in educational institutions in the district of Turbo-Antioquia, Colombia.

## Keywords:-

ICT, academic management, administrative management, integration, pedagogical practices

# Green Synthesis Of Metal Oxide Nanoparticles From The Whole Plant Extract Of *Catharanthus Pusillus*(Murr.) G.Don(Apocynaceae) And Their Enhanced Antioxidant Activity

**Yokeswari Nithya P**

Department of Chemistry, A.P.C.Mahalaxmi College for Women, Thoothukudi, Tamil Nadu, India  
Email: yokeswarinithya@gmail.com

## **Abstract:-**

Plants are known to possess therapeutic compounds which are being exploited since ancient times as a traditional medicine. Due its huge diversity plants have been explored constantly for wide range of applications in the field of pharmaceutical, agricultural, industrial etc. The scope of the project is synthesise and characterize the Barium oxide nanoparticles from the whole plant extract of *Catharanthus pusillus* (*Apocynaceae*). The synthesized nanoparticles were characterized by using PL, XRD, SEM, UV, and IR spectrum. Antioxidant study of synthesized nanoparticles were also carried out.

## **Keywords:-**

Catharanthus pusillus, SEM, EDAX, XRD & PL



# Raising Student Engagement in e-Learning Environment: An Analysis of VLE Learning Resources

<sup>[1]</sup> Abu Hassan Darusman, <sup>[2]</sup> Yuhanis Omar

<sup>[1]</sup> Universiti Kuala Lumpur, Malaysia France Institute, Bandar Baru Bangi, Selangor, Malaysia

<sup>[2]</sup> Universiti Kuala Lumpur, Malaysian Institute of Information Technology, Kuala Lumpur, Malaysia

Email: <sup>[1]</sup> abuhassan@unikl.edu.my, <sup>[2]</sup> yuhanis@unikl.edu.my

## Abstract:-

For many years, e-learning is one of the topics of interest among academia. The increase of wireless devices and smartphone usage as the current technology and platform to access internet services plays an important role in e-learning to be used in teaching and learning activities. Virtual Learning Environment (VLE) is a web-based system designed to facilitate e-learning with various elements in it. However, one of the biggest challenges in implementing e-learning with an efficient and effective learning resources component is the lack of motivation and student engagement in using it continuously. Therefore, the objective of this study is to gather the students' perceptions and suggestions about learning resources in VLE that can be used to raise their level of motivation and engagement in the e-learning environment. The aim of this paper is to discuss the findings of preliminary investigation related to the elements or characteristics of learning resources that can fulfill the need of the students in their studies at university. This study used a qualitative approach by interviewing a group of 60 students to; (1) get their perceptions on the existing learning resources, (2) identify the issues or challenges in using the existing learning resources, and (3) record the suggestions that can be considered to improve the learning resources in VLE to make them motivated and engaged to the e-learning platform continuously. The results in a form of suggestions can be used as a guideline for academia to improve their learning resources.

## Keywords:-

e-learning; virtual reality; gamification; motivation; engagement

# Studies On Mechanical, Thermal And Third Order Nlo Properties Of Potassium Magnesium Sulphate Crystals

**N.Rathna**

Assistant Professor of Physics, A.P.C. Mahalaxmi College for Women, Thoothukudi, Tamil Nadu, India  
Email: rathmut@gmail.com

## **Abstract:-**

Nonlinear Optical (NLO) crystals provides the key functions of frequency shifting, optical modulation, optical switching, and optical memory for the emerging techniques in areas of telecommunication, signal processing and optical interconnections. Potassium Magnesium Sulphate (PMS) is an inorganic material belonging to the family of Tutton's salts. Single crystals of Potassium Magnesium Sulphate are grown by the slow evaporation technique. The crystals are subjected to single crystal X-ray diffraction to analyze the crystal lattice parameters, and the crystal structure is found to be monoclinic. The hardness values of the grown sample have been found by Vickers Micro hardness test. To find the thermal stability, exothermic and endothermic transitions, melting point and decomposition point of the samples TG/DTA studies were also carried out. Third-order nonlinear parameters are evaluated by the Z scan technique. The nonlinear optical parameters such as nonlinear refractive index  $n_2$ , nonlinear absorption coefficient  $\beta$  and nonlinear susceptibility  $\chi^{(3)}$  are also determined.

## **Keywords:-**

Crystal Growth, NLO Crystal, X-ray diffraction, TG/DTA, Z Scan

# Industrial Automation Communications and Development using High Speed Internet (IIoT With 5G)

<sup>[1]</sup>Yahya Alward, <sup>[2]</sup>M. A. Ansar

<sup>[1][2]</sup>Electrical Engineering Department, SoE, Gautam Buddha University, India

## Abstract:-

Industrial Automation is one of the most things to care about in the manufacturing environment to enable the high level of productions system. A lot of errors were shown in the production lines due to the communications issues and the level of safety still needs to be improving to make the production environment more perfect and safe. The communication between the devices (Device to Device, D2D) and machines (Machine to Machine, M2M) must be in high level that will make the data processing between them ideal. This papers presents importance, future and challenges of IIoT with 5G networks. The wireless communications for industries has the power to process data with high speed comparing to the traditional connections. Nowadays 4G is using in different industries that showing good results but the demon of the market of qualities and quantities still need to be improve to reach the concepts of the industrial market. Hence using of internet of things (IoT) with 5G networks will make the required improvements for the industries connections and will make increase the product's qualities and quantities in very short time. Industrial Internet of things (IIOT) is a perfect solution for the industries due to the high speed comparing to the 4G/LTE and the processing of the data is much higher and less time reached to less than 0.003 m Second.

## Keywords:-

Automation, Production, 5G, wireless, Communication, Industrial

# Pedagogical Leadership And Educational Management In The Teaching Practice Of SENA In Colombia

<sup>[1]</sup> Verónica Johana Suárez Molina, <sup>[2]</sup> José Luis Rodríguez López, <sup>[3]</sup> Judith Soledad Yangali Vicente

<sup>[1]</sup> Corporación Universitaria Minuto de Dios

<sup>[2]</sup> Universidad Tecnológica del Perú

<sup>[3]</sup> Universidad Norbert Wiener

Email: <sup>[1]</sup> verosu6@gmail.com, <sup>[2]</sup> luisjoserodriguez1512@gmail.com, <sup>[3]</sup> judith.yangali@uwiener.edu.pe

## Abstract:-

The purpose of the research was to determine the influence of pedagogical leadership and educational management on the teaching practice of the SENA's technical and technological training centers in Colombia. The study has a mixed approach, in the quantitative approach it was the non-experimental design and in the qualitative approach it followed the phenomenological-hermeneutic design. For the quantitative study, the population was made up of 201 professional instructors, located in 33 regions of Colombia where the SENA is present, and for the qualitative study, 8 teaching directors. The application instruments were a questionnaire and a semi-structured interview guide. In conclusion, there is a relationship between the influence of the pedagogical leadership of the direction and the educational management in the teaching practice of the SENA training centers in Colombia.

## Keywords:-

Pedagogical leadership, educational management, teaching practice, training centers



# The Administration Model Complexity of School under the Secondary Educational Service Area Office

<sup>[1]</sup> Phramaha Santichai Abhisanti, <sup>[2]</sup> Dr. Somsak Boonpoo, <sup>[3]</sup> Dr. Rawing Ruangsanka,  
<sup>[4]</sup> Mr. Veerapan Pongvatnanusorn

<sup>[1][2][3][4]</sup> Mahachulalongkornrajavidyalaya University, Thailand

## Abstract:-

The purposes of this research were 1) to study the state of problem in complex administration of School Under the Secondary Educational Service Area Office, 2) to develop and propose the administration model complexity of school under the Secondary Educational Service Area Office. Mixed methods research was used for research design. In qualitative research was conducted by using documentary study, in-depth interview with 5 key informants and focus group discussion with 9 experts. Research tools were documentary record form and interview form. In quantitative research, 400 samples of secondary school administrators and teachers were used for data collection and was selected by multistage random sampling. Research tool was questionnaires. Qualitative data was analyzed by content analysis whereas quantitative data were analyzed by percentage, frequency, mean, and standard deviation. Results indicated that 1) the state of problem in complex administration of School Under the Secondary Educational Service Area Office consisted of 4 aspects and overall has shown the balanced level of complexity that was the problem solving consisted of (1) to encourage community to have strong academic administration in academic management, (2) to set up fund raising of resources to support education in financial management, (3) to set human resource planning for educational personnel in human management, and (4) to conduct research for policy and plan development in general administration. 2) The administration model complexity of school under the Secondary Educational Service Area Office consisted of 5 components which were (1) the principle of complexity, (2) the objective of complex administration, (3) process of complex administration, (4) model utilization, and (5) key success factors. Results of validation based on 4 standards in overall was at high level.

## Keywords:-

Administration Model Complexity, Complex Administration, Secondary Educational Service Area Office



**IFERP International Conference**  
**IFERP Explore**  
<https://icset.net> | [info@icset.net](mailto:info@icset.net)

**UPCOMING CONFERENCES**



**Echnoarete<sup>®</sup> Group**

Integrating Researchers to Incubate Innovation

**SUPPORTED BY**

